



# Portable Surface Roughness Gauge

*Part No. SRG-4000*



## Operation Manual

• Machine Accessories • Precision Tools • Cutting Tools • Material Testing Instruments  
(201)962-7373  
WWW.PHASE2PLUS.COM



**Introduction:**

The SRG-4000 is a portable, battery powered instrument used for checking surface finish with the measured values displayed on a digital readout. This instrument can be utilized in a laboratory setting, a shop inspection area, or wherever on-site surface roughness testing is required.

**Note:**

Although this instrument is designed and built to withstand the rigors of handling and usage, it is a sensitive precision instrument and should be treated with care to assure measurement accuracy and reliable performance.

The SRG-4000 is furnished in a fitted case and includes the following:

- a) SRG-4000 unit with general purpose probe
- b) Precision Reference Standard
- c) Screwdriver
- d) A/C Adapter

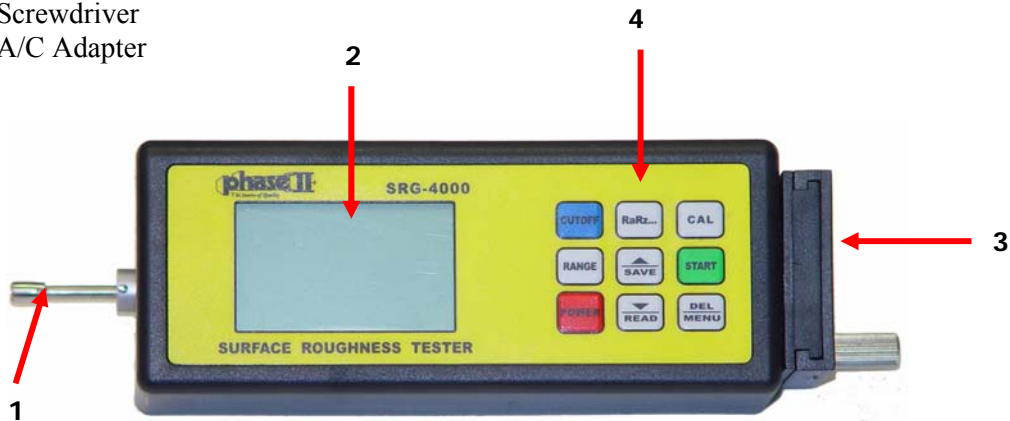

- 1) 5µm Diamond Stylus
- 2) LCD Display
- 3) Levelling bracket
- 4) Keypad



## Specifications:

<b>Measuring Ranges:</b>	Ra, Rq—0.005 $\mu\text{m}$ ~ 16 $\mu\text{m}$ / 0.020 $\mu\text{m}$ ” ~ 629.99 $\mu\text{m}$ ” Rz, Rt—0.020 $\mu\text{m}$ ~ 16 $\mu\text{m}$ / 0.078 $\mu\text{m}$ ” ~ 629.9 $\mu\text{m}$ ”
<b>Display Resolution:</b>	<b>0.001<math>\mu\text{m}</math></b> < 10 $\mu\text{m}$ 0.01 $\mu\text{m}$ between 10 $\mu\text{m}$ < 100 $\mu\text{m}$ 0.1 $\mu\text{m}$ > 100 $\mu\text{m}$
<b>Cutoff:</b>	0.25mm / 0.8mm / 2.5mm
<b>Display:</b>	4- Digit LCD
<b>Measuring Accuracy:</b>	Not more than +/-10% of actual value
<b>Probe Type:</b>	Piezoelectric / 5 $\mu\text{m}$ Diamond Tip
<b>Maximum Stylus Force:</b>	4.0mN
<b>Power Supply:</b>	Lithium-Ion Rechargeable Battery
<b>Operating Temp:</b>	50° - 113° F
<b>Storage Temp:</b>	32° - 147° F
<b>Humidity:</b>	<80%

## Surface Finish Definitions:

- 1) **Ra:** Ra is the arithmetic average of the absolute values of the roughness profile ordinates. Also known as Arithmetic Average (AA), Center Line Average (CLA). The average roughness is the area between the roughness profile and its mean line, or the integral of the absolute value of the roughness profile height over the evaluation length
- 2) **Rz:** Rz is the arithmetic mean value of the single roughness depths of consecutive sampling lengths. Z is the sum of the height of the highest peaks and the lowest valley depth within a sampling length.
- 3) **Cutoff  $\lambda\text{c}$ :** of a profile filter determines which wavelengths belong to roughness and which ones to waviness.
- 4) **Sampling Length:** is the reference for roughness evaluation. Its length is equal to the cutoff wavelength.
- 5) **Traversing Length:** is the overall length traveled by the stylus when acquiring the traced profile. It is the total of Pre-travel, evaluation length and post travel
- 6) **Evaluation Length:** is the part of the traversing length from where the values of the surface parameters are determined.

**Measurement Parameters:**

**Ra = Roughness Average.** The arithmetic average height of roughness irregularities measured from a mean line within the evaluation length (L)

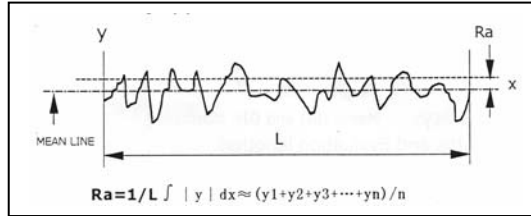

**Rz = Mean Roughness Depth.** The mean of 5 maximum peak to valley roughness depths in 5 successive sampling lengths

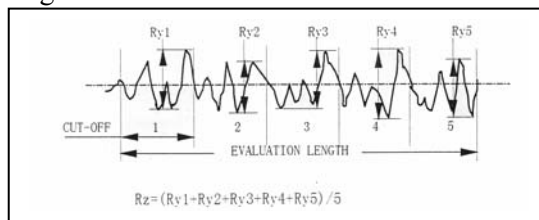

**Rq = Maximum Roughness Depth.** The largest peak to valley roughness depth in the evaluation length

**Rq - Root-Mean-Square Roughness**

The root-mean-square (rms) average roughness of a surface is calculated from another integral of the roughness profile:

For a pure sine wave of any wavelength and amplitude Rq is proportional to Ra; it's about 1.11 times larger. Older instruments made use of this approximation by calculating Rq with analog electronics (which is easier than calculating with analog electronics) and then multiplying by 1.11 to report Rq. However, real profiles are not simple sine waves, and the approximation often fails miserably. Modern instruments either digitize the profile or do not report Rq. There is never any reason to make the approximation that is proportional to Ra. Rq has now been almost completely superseded by Ra in metal machining specifications. Rq still has value in optical applications where it is more directly related to the optical quality of a surface.

**Rt**, is the vertical distance from the deepest valley to the highest peak. (sum of maximum height of the profile peak and max. depth of the profile valley for the evaluation length)

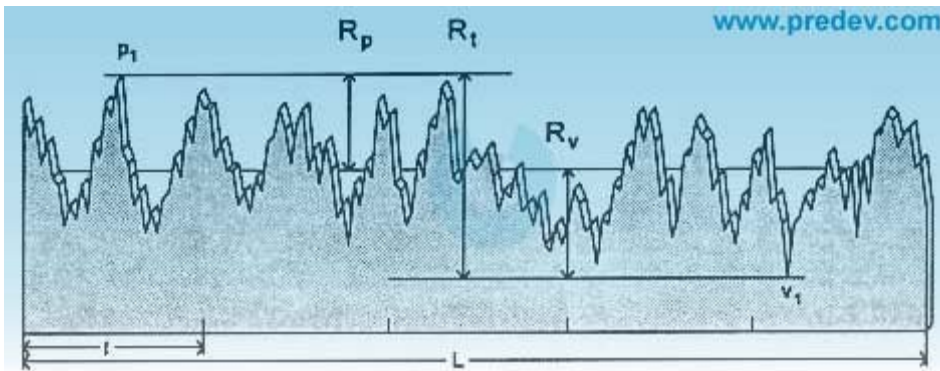

## System Set-Up Procedure:

### a) On / Off



Press the  Button to power the unit on. This instrument will save all parameters that were set from the last performed test. Assuming that the parameters are correct for the current application, you can begin testing at your convenience.

### b) Setting the Cut-Off Length:



Press the  button to toggle between the 3 available Cut-Off lengths: (0.8mm, .25mm, 2.52mm)

*(most common applications should be set for 2.5mm)*

Ra (um)	Rz (um)	SAMPLING LENGTH/mm
>5 - 10	20 - 40	2.5mm
>2.5 - 5	>10 - 20	2.5
>1.25 - 2.5	>6.3 - 0	0.8
>0.63 - 1.25	>3.2 - 6.3	0.8
>0.32 - 0.63	>1.6 - 3.2	0.8
>0.25 - 0.32	>1.25 - 1.6	0.25
>0.20 - 0.25	>1.0 - 1.25	0.25
>0.16 - 0.20	>0.8 - 1.0	0.25
>0.125 - 0.16	>0.63 - 0.8	0.25
>0.1 - 0.125	>0.5 - 0.63	0.25
>0.08 - 0.1	>0.4 - 0.5	0.25
>0.063 - 0.08	>0.32 - 0.4	0.25
>0.05 - 0.063	>0.25 - 0.32	0.25
>0.04 - 0.05	>0.2 - 0.25	0.25
>0.032 - 0.04	>0.16 - 0.2	0.25
>0.025 - 0.032	>0.125 - 0.16	0.25
>0.02 - 0.025	>0.1 - 0.125	0.25

**c) Setting the Filter Profile:** *(Most typical applications should be set for RC Filter)*



Press the  button and hold for approx. 3 seconds until "Filt" appears on the

display. To toggle between the filter, press either the  or  buttons.

Once selection is made, Press any other button EXCEPT the  or  to save selection.

**d) Selecting Inch ( $\mu$ in) or Metric ( $\mu$ m) readout:**



Press the  button and hold it until "Unit" appears on the display. To toggle

between the measuring units, press either the  or  buttons. Once

selection is made, Press any other button EXCEPT the  or  to save selection.

**e) Selection of Roughness Scale: Ra, Rz, Rq(Rms), Rt**

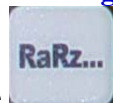

Press the  button to toggle through the 4 available roughness scales

**f) Selecting Range (Evaluation Length) readout: 1-5**

*This parameter is the part of the traversing length from where the values of the surface parameters are determined (1L, 2L, 3L, 4L, 5L)*



Press the  button and hold it until "1L" appears on the display. To change

from 1-5 evaluation lengths, press either the  or  buttons. Once

selection is made, Press any other button EXCEPT the  to save selection.

## Surface Preparation:

Be sure to clean surface from any liquids, viscous fluids, metal chips, dust and rust. Any paint type coatings should be removed prior to test.

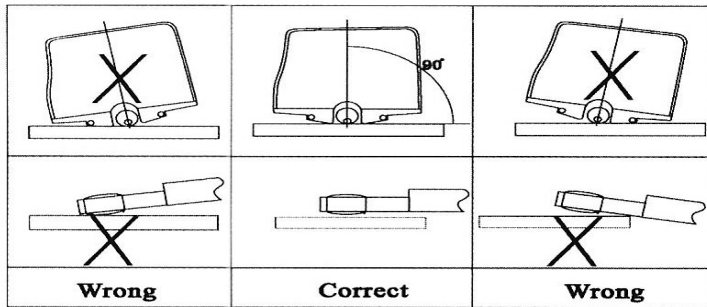

Fig. 4-1

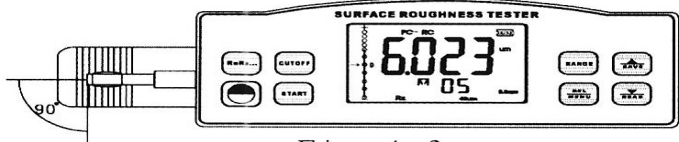

Fig. 4-2

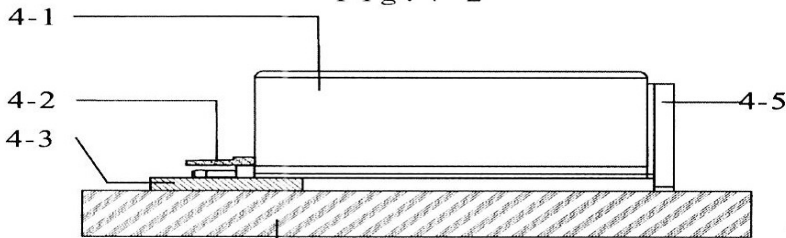

Fig. 4-3

- 4-1 Roughness tester
- 4-2 Sheath of probe
- 4-3 Item to be measured
- 4-4 Working table
- 4-5 Adjustable leg

## Placement of Tester:

- a) Be sure to set the unit flat as seen in **Figure 4-1**. The built in level indicator on the display will help you get set to "0".
- b) The sliding trail of the stylus must be vertical to the direction of the process line ("across the grain") of the measured surface. See **Figure 4-2**
- c) When the measured surface is smaller than the bottom surface of the instrument, the stylus sheath and adjustable leg can be used as auxiliary support to complete the measurement. See **Figure 4-3**



## Begin Measurements:

Once the unit is placed on the part to be tested you should press the START button. You will see the display show 4 dashes as the stylus is making its pass. Once the stylus returns to its starting position, the roughness value will be shown on the display.

## Saving your results:

After measuring, you will see the letter “M” will now have a dash over the top of the letter. In this state, you can now save this group of results to memory by pressing the



button. Then the M with the dash over it will change to a regular “M” without the dash over it automatically while the number of memorized groups increases to “1”.

## Browsing Parameters:

While in the “M” with the dash over it state, you can toggle between different roughness scales (Ra, Rz, etc.)

## Deleting Measurements:

While in the “M” with the dash over it state, you can delete this group of results by



depressing the button. Then the M with the dash over it will now become just the regular “M”. New measurements will replace the old measurements if you press the Start button while in the M dash state.

## Browsing Memorized Data:



Regardless of the “M” state, you can see your results by pressing the button. This browsing state is marked on the display with the letter “R”

When in the “R” state, you can browse different groups by pressing the

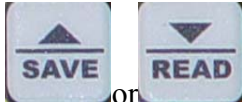

buttons. The serial number of the group will show on the display. For each group, you can still browse through the roughness scales. When picking a roughness scale, the unit will give you the results in the corresponding scale.





## How to Calibrate the Tester:



To enter into calibration, turn the unit on and press and hold the **DEL MENU** button until “CAL” is shown on the display. At that moment, release the button.

Take a measurement on the supplied reference standard or your own precision standard and view the results.

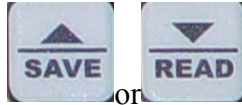

To adjust your values, press the **SAVE** or **READ** buttons to correlate with the value on the standard. Repeat this step until the reading is within acceptable tolerance.

To Save this calibration Press any button EXCEPT for START. Display error should be less than +/- 10% of the actual value.

## Restoring Factory Settings:

It is necessary to restore when replacing a worn probe(stylus) or installing one of the optional stylus for grooves or bores.



Press and hold the **DEL MENU** button until “FAC” is shown on the display. It will take approx. 12-16 seconds for the unit to reach the FAC screen. This state is also marked by “CAL”.

Place the unit on your supplied reference standard and press the START button.

While the probe is moving forward, you will notice that the numbers on the display will vary with the movement.

At this time, you must use your supplied screwdriver and adjust the resistance (see figure 3-35) and allow the reading on the display to come close to the value on the standard.

After the test has completed, you must re-calibrate the unit as stated on the previous page.

## Battery Charging:

The SRG-4000 is supplied with a Nimh Rechargeable Battery.

This unit can be charged 2 ways. Wall Socket or PC.

By plugging the USB cable into the supplied plug, you can charge the unit by plugging it in to your wall socket.

By plugging the USB end of the cable into your PC, you can also charge the unit.

Either way, the SRG-4000 will function while charging.



## **Maintenance:**

### ***Protection and Storage***

To protect the tester when not in use, always remove the probe from the base unit and store in the supplied plastic case. Also, when not in use, always keep the tester and its accessories in the carry case.

### **Cleaning:**

To clean the outside of the tester, use a soft, lint free cloth moistened with a mild non-abrasive liquid or foam cleaner. Periodically inspect the skid surface and stylus for dust, dirt or other contaminants. To clean the skid surface, use a soft brush moistened with rubbing alcohol.

### **Repairs:**

Please contact Phase II for instructions.

**Do not disassemble the unit or attempt any internal repairs as this will void the existing warranty.**

## **Accessories for SRG-4000**

<b>Part No.</b>	<b>Description</b>
SRG4000-050	Precision Support Stand
SRG4000-110	Stylus Extension
SRG4000-130	2 $\mu$ m Stylus (for ultra smooth surfaces)

## Precision Test Stand

Model No. SRG4000-050



Figure 1:  
New Swivel adapter shown at right

### ***Mounting SRG-4000 to the stand:***

- a) Remove two screws from Leveling plate on the right side of the unit as shown in Fig 2.
- b) Use those two screws to mount the SRG-4000 to the Mounting Bracket as shown in Figure 1.
- c) Place leveling plate in carry case for future use without stand.

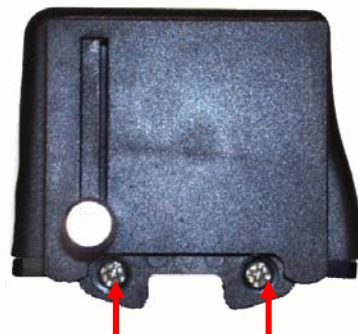

Figure 2:

**phase II+**  
"The Source of Quality"

# Global Connections



## **Main Headquarters: U.S.A**

### **Phase II Machine & Tool, Inc.**

21 Industrial Ave  
Upper Saddle River, NJ. 07458 USA  
Tel: (201) 962-7373  
Fax: (201) 962-8353  
General E-Mail: [info@phase2plus.com](mailto:info@phase2plus.com)

## **BEIJING, CHINA**

### **Phase II Measuring Instruments (Beijing) Ltd.**

Room 301, Bldg 2 Qing Yuan Xi Li, Haidian District, Beijing 100192, China  
Tel: +86-10-59792409  
Fax: +86-10-59814851  
General E-mail: [info@phase2china.com.cn](mailto:info@phase2china.com.cn)

## **MEXICO**

### **Phase II de Mexico**

Calle A No. 4 Promer Piso  
Col. San Marcos Azcapotzalco  
C.P 02020 Mexico  
Tel: 011-525-5538-39771  
Fax: same  
General E-mail: [phase2mexico@hotmail.com](mailto:phase2mexico@hotmail.com)

## **VENEZUELA**

### **Phase II Herramientas Universales EDCM. CA.**

Av. Francisco Lazo Marti CC  
Plaza Santa Monica PB Local  
Santa Monica, Caracas 1040 Venezuela  
Tel: 212-690-28-21  
Fax: 212-693-29-16  
E-mail: [edcphm@movistar.net](mailto:edcphm@movistar.net)

• Machine Accessories • Precision Tools • Cutting Tools • Material Testing Instruments  
(201)962-7373  
[WWW.PHASE2PLUS.COM](http://WWW.PHASE2PLUS.COM)