

## TOUCH OFF GAGE OWNER'S MANUAL

THE TOUCH OFF GAGE IS DESIGNED TO QUICKLY AND ACCURATELY SET TOOL OFFSETS FOR ANY CNC MILL. IT CAN DECREASE SET UP TIME AND ELIMINATE TOOL PATH MISMATCH.

[WWW.EDGETECHNOLOGYPRODUCTS.COM](http://WWW.EDGETECHNOLOGYPRODUCTS.COM)

### OPERATION

- SLOWLY LOWER CUTTING TOOL DOWN ONTO THE CONTACT FACE OF THE UNIT. CONTINUE LOWERING THE TOOL UNTIL THE INDICATOR READS ZERO.
- INPUT A 4.000" TOOL LENGTH OFFSET INTO THE CONTROL.



### RECTANGULAR BASE

- THE RECTANGULAR BASE AND RECESSED INDICATOR FACE ALLOW IT TO FIT BETWEEN VISE JAWS ON A PAIR OF PARALLEL BARS.

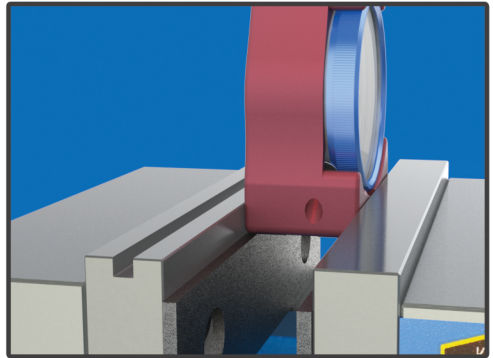

### CALIBRATION

- THE 4.000" OFFSET HEIGHT CAN EASILY BE VERIFIED WITH THE USE OF A FEW 1-2-3 BLOCKS. IF NECESSARY THE INDICATOR FACE CLAMP SCREW CAN BE ADJUSTED BY INSERTING A 1.5MM ALLEN WRENCH IN THE ACCESS HOLE LOCATED IN THE LOWER LEFT CORNER OF THE BODY.

