

AIR MICRO GRINDER FOR INDUSTRIAL USE

FREE SPEED..... 58,000PRM
 COLLET SIZE..... 3MM or 1/8 "
 NET WEIGHT..... 0.33 KGS
 LENGTH..... 132MM
 AIR PRESSURE.....90 PSI

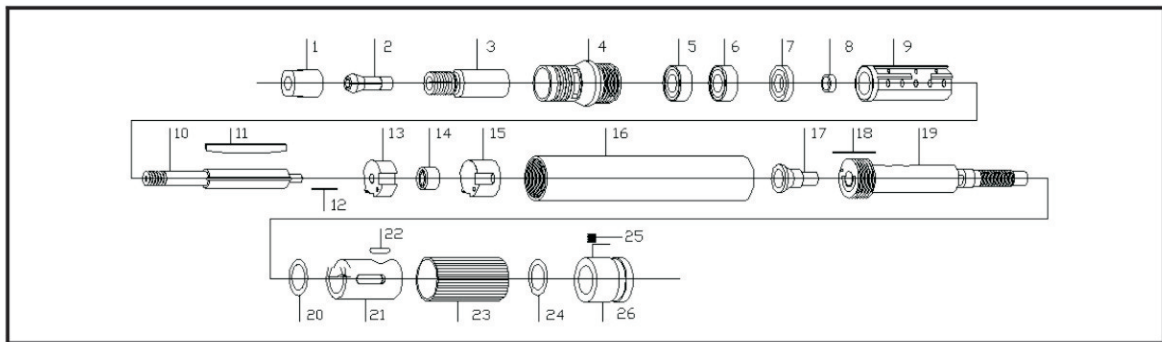

PART LIST

INDEX NO.	NUMBER	DESCRIPTION
1	1	CLAMPING NUT
2	1	COLLET
3	1	FRONT COVER
4	1	COLLET FONDATION
5	1	BALL BEARING
6	1	BALL BEARING
7	1	SPACER
8	1	LATERAL DISC
9	1	CYLINDER
10	3	ROTOR
11	1	FIBRE VANES
12	1	PIN
13	1	BEARING PLATE

INDEX NO.	NUMBER	DESCRIPTION
14	1	BALL BEARING
15	1	INTAKE PLATE
16	1	SLEEVE
17	1	INTAKE TIE-IN
18	1	PIN
19	1	HOSE PLUG
20	1	ORING
21	1	KNOB IN-HOUSE SLIPCOVER
22	1	ORING
23	1	SLIDING KNOB
24	1	ORING
25	1	SCREW
26	1	REAR END HOLDER

OPERATION INSTRUCTION

- Step 1. Set up selected grinding tools on the chuck of the air grinder.
2. Connected the air line accessory at the end of air hose.
3. Turn on slowly and gradually clockwise the variable speed switch in silver color when start the motor.
4. Turn off counter clockwise the variable speed switch in silver color when stop the motor.

Caution: Please pay attention to operation when turning on the silver variable switch to keep the speed slowly and gradually so that to maintain the motor always in operable condition.