

OTMT

6" TOOL GRINDER - 1/2 HP

SET UP AND OPERATING INSTRUCTIONS



**ITEM NO.87-002-335
MODEL NO.TG-6L**

Version date: 05/25/2012

Please Read These Instructions Before Operating Your Machine
Contents Subject To Change Without Notice

CONTENTS

Specifications Table	1
Save This Manual	1
Safety Warnings And Precautions	2
Specific Product Warnings And Precautions	3
Unpacking	5
Product Overview	5
Mounting Instructions	6
Assembly Instructions	6
Operating Instructions	7
Basic Procedures.....	7
To Grind A Tool.....	8
Inspection, Maintenance, And Cleaning	9
Inspection.....	9
Maintenance.....	9
Cleaning.....	9
Please Read The Following Carefully	9
Parts List	10
Assembly Diagram	11

SPECIFICATIONS TABLE

Electrical Requirements	1/2 HP, 115 V~, 60 Hz, 4.6A,
	Single Phase, 3,400 RPM
	Bulb (not included): 120 V, 40 W, Type-A
Construction	Cast Iron Base, Motor Housing, Catch Basins
	Cast Aluminum Table
Water Cup	Adjustable
Wheel Size	6" Maximum Diameter
Arbor Size	1.250" Diameter
Rotation Arrows	Dual Arrows
Overall Dimensions	15" W x 25" L x 16" H w/Water Cup
Base Dimensions	8" W x 8-1/2" L
Mounting Holes	4 at 5/16" (.30") Diameter
Table Dimensions	6-3/4" W x 12" L
Table Surface	Grounded

SAVE THIS MANUAL

You will need this manual for the safety warnings and precautions, operating, inspection, maintenance, and cleaning procedures, parts list and diagram. Keep your invoice with this manual. Write the invoice number on the inside of the front cover. Keep this manual and invoice in a safe and dry place for future reference.



SAFETY WARNINGS AND PRECAUTIONS

1. **KEEP WORK AREA CLEAN AND DRY.** Cluttered, damp or wet work areas invite injuries.
2. **KEEP CHILDREN AWAY FROM WORK AREA.** Do not allow children to handle this product.
3. **STORE IDLE EQUIPMENT.** When not in use, tools and equipment should be stored in a dry location to inhibit rust. Always lock up tools and equipment and keep out of reach of children.
4. **DO NOT USE THIS PRODUCT IF UNDER THE INFLUENCE OF ALCOHOL OR DRUGS.**
Read warning labels on prescriptions to determine if your judgement or reflexes are impaired while taking drugs. If there is any doubt, do not attempt to use this tool.
5. **USE EYE AND HEARING PROTECTION.** Wear ANSI approved safety impact eye glasses, full face shield and ANSI approved hearing protectors when working with this product.
6. **DRESS SAFELY.** Non-skid footwear or safety shoes should be used when working with this product. Do not wear loose clothing or jewelry as they can become caught in moving parts. Wear a protective hair covering to prevent long hair from becoming caught in moving parts.
7. **INDUSTRIAL APPLICATIONS MUST FOLLOW OSHA REQUIREMENTS.**
8. **DO NOT OVERREACH.** Keep proper footing and balance at all times to prevent tripping, falling, back injury, etcetera.
9. **STAY ALERT.** Watch what you are doing at all times. Use common sense. Do not use this tool when you are tired or distracted from the job at hand.
10. **CHECK FOR DAMAGED PARTS.** Before using this product, carefully check that this machine will operate properly and perform its intended function. Check for damaged parts and any other conditions that may affect the operation of this machine. Replace or repair damaged or worn parts immediately.
11. **REPLACEMENT PARTS AND ACCESSORIES.** When servicing, use only identical replacement parts. Only use accessories intended for use with this product.
12. **MAINTAIN THIS PRODUCT WITH CARE.** Keep this tool clean and dry for better and safer performance.
13. **MAINTENANCE:** For your safety, service and maintenance should be performed regularly by a qualified technician.
14. **USE THE RIGHT PRODUCT FOR THE RIGHT JOB.** There are certain applications for which this product was designed. Do not use a small tool or attachment to do the work of a larger industrial tool or attachment. Do not use this product for a purpose for which it was not intended.
15. **WARNING:** The warnings, cautions, and instructions discussed in this manual cannot cover all possible conditions and situations that may occur. It must be understood by the operator that common sense and caution are factors which cannot be built into this product, but must be supplied by the operator.



SPECIFIC PRODUCT WARNINGS AND PRECAUTIONS

1. **ALWAYS DISCONNECT THIS MACHINE FROM ITS ELECTRICAL SUPPLY SOURCE BEFORE PERFORMING ANY SERVICES OR MAINTENANCE.** Make sure to turn off the Tool Grinder prior to cleaning it, changing work pieces and/or tool accessories, etcetera.
2. **DO NOT LEAVE THIS MACHINE RUNNING UNATTENDED.** Turn off the power and wait until the machine stops running before leaving.
3. **GROUND THIS MACHINE.** The electrical Power Cord for this product is equipped with a grounded, 3-prong Plug (69). Make sure this product is always plugged into a grounded, 115 Volt, 3-hole electrical receptacle.
4. **MAKE SURE THE SWITCH (50) IS IN THE "OFF" POSITION BEFORE PLUGGING IN THE POWER CORD (69).**
5. **DO NOT ABUSE THE POWER CORD (69).** Do not yank the Power Cord to disconnect it from the electrical receptacle. Do not move this machine with the Power Cord in the outlet. Keep the Power Cord away from heat, oil, and sharp edges.

RECOMMENDED MINIMUM WIRE GAUGE FOR EXTENSION CORDS (120 VOLT)				
NAMEPLATE AMPERES (at full load)	EXTENSION CORD LENGTH			
	25'	50'	100'	150'
0 – 6	18	16	16	14
6.1 – 10	18	16	14	12
10.1 – 12	16	16	14	12
12.1 – 16	14	12	Do not use.	

TABLE A

6. **WHEN USING EXTENSION CORDS:** The extension cord must have a minimum wire size depending on the amperage of the tool and length of the extension cord. **This Tool Grinder is rated at 6.3 motor amps.** The extension cord size is determined by its AWG (American Wire Gauge) rating. The smaller the gauge, the greater the cable's capacity. The amount of cords used does not matter – total length determines the minimum AWG rating. Every cord must meet the AWG rating. Use **Table A** above to determine what AWG rating is required for your situation. Cord length is rated in feet.
7. **KEEP ALL GUARDS IN PLACE AND IN WORKING ORDER.**
8. **REMOVE ADJUSTING KEYS AND WRENCHES.** Check to make sure all adjusting tools are removed from this product before turning it on.
9. **MAINTAIN A SAFE WORK ENVIRONMENT.** Do not use this product in or near damp or wet areas. Do not expose this product to rain. Keep the work area well lit. Make sure there is adequate surrounding workspace. Use this product in a well ventilated area. **Do not operate this product in the presence of flammable liquids, gasses, or dust.** To avoid accidental electric shock, do not let your body come in contact with grounded surfaces such as pipes, radiators, ranges, etcetera.

10. **DO NOT FORCE THE EQUIPMENT.** This Tool Grinder will do the work better and safer at the speed and capacity for which it was designed.
11. **AVOID UNINTENTIONAL STARTING.** Make sure you are prepared to begin work before turning the Switch (50) on.
12. **NEVER ATTEMPT TO REMOVE MATERIAL STUCK IN THE MOVING PARTS OF THIS MACHINE WHILE THE MACHINE IS PLUGGED IN AND RUNNING.**
13. **MAKE SURE THIS MACHINE IS MOUNTED SECURELY ON A FLAT, LEVEL, STURDY WORKBENCH CAPABLE OF SUPPORTING THE WEIGHT OF THE MACHINE, WORK PIECE, TOOLS, ACCESSORIES.**
14. **WARNING:** Some dust created by power sanding, sawing, grinding, drilling, and other construction activities, contain chemicals known (to the State of California) to cause cancer, birth defects or other reproductive harm. Some examples of these chemicals are: lead from lead-based paints, crystalline silica from bricks and cement or other masonry products, arsenic and chromium from chemical treated lumber. Your risk from these exposures varies, depending on how often you do this type of work. To reduce your exposure to these chemicals: work in a well ventilated area, and work with approved safety equipment, such as those dust masks that are specially designed to filter out microscopic particles.
(California Health & Safety Code 25249.5, et seq.)
15. **WARNING:** Handling the cord on this product will expose you to lead, a chemical known to the State of California to cause cancer, and birth defects or other reproductive harm. Wash hands after handling.
(California Health & Safety Code § 25249.5, et seq.)
16. People with pacemakers should consult their physician(s) before use. Electromagnetic fields in close proximity to heart pacemaker could cause pacemaker interference or pacemaker failure.

UNPACKING

When unpacking, check to make sure all the parts shown on the Parts List (page 10) are included.

PRODUCT OVERVIEW

NOTE: Prior to operating the Tool Grinder, make sure you familiarize yourself with the main parts components and their functions. (See Figures B and C.)

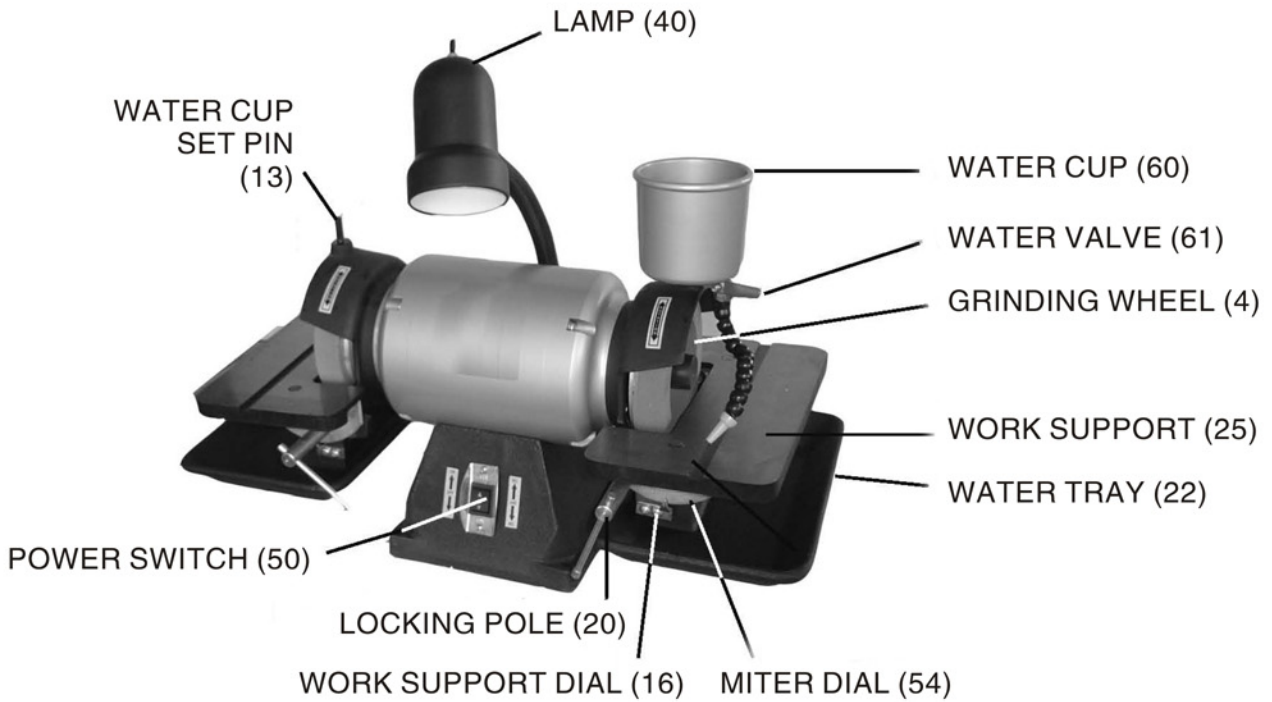

↑ FIGURES B

Part	Function
Power Switch (50)	Press the top Arrow for “ON,” and to turn the Grinding Wheel (4) in an upward direction. Press the bottom Arrow for “ON,” and to turn the Grinding Wheel (4) in a downward direction. Move the Switch to its “O” position to turn the machine “OFF.”
Water Cup Set Pin (13)	Holds Water Cup (60) in position.
Lamp (40)	Adjustable positioning.
Water Cup (60)	Fits on right or left side of machine.
Water Valve (61)	Turn horizontally for “OFF.” Turn vertically for “ON.”
Grinding Wheel (4)	Do not exceed 6" maximum diameter.
Miter Dial (54)	Adjustable: 0–45 degrees right or left.
Work Support (25) Work Support Dial (16) Locking Pole (20)	Adjustable: 0–45 degrees up or down.
Water Tray (22)	Removable for emptying/cleaning.

↑ FIGURES C

MOUNTING INSTRUCTIONS

NOTE:

For further reference to the parts mentioned below, refer to the Parts List and Assembly Diagram on pages 10 and 11 of this manual.

CAUTION!

Mount the Tool Grinder on a flat, level, sturdy workbench capable of supporting the weight of the Tool Grinder, accessories, and work piece.

NOTE:

Four 5/16" mounting holes are located at the bottom of the Motor Base (37).

1. With assistance, set the Tool Grinder in the desired location on the top of the workbench.

- Using the four 5/16" mounting holes as a template, mark the four holes that are to be drilled through the top of the workbench. Then, temporarily remove the Tool Grinder.
2. Using a drill and a 5/16" drill bit (not provided), drill the four previously marked holes completely through the workbench.
3. Align the 5/16" mounting holes at the bottom of the Motor Base (37) with the four previously drilled 5/16" holes in the workbench. Then, secure the Tool Grinder to the workbench using four appropriate length 5/16" bolts, four lock washers, and four nuts (not provided).

ASSEMBLY INSTRUCTIONS

NOTE:

For further reference to the parts mentioned below, refer to the Parts List and Assembly Diagram on pages 10 and 11 of this manual.

1. To assemble a Grinding Wheel (4) on the **right** side of the Tool Grinder, remove the Shaft End Bushing (1). Remove the Hex Nut (2), and remove the Hex Socket Head Shoulder Screw (3). **(See Figure B.)**
2. Slide the Grinding Wheel (4) onto the Adjusting Bushing (27). **(See Figure B.)**
3. In order, reattach the Hex Socket Head Shoulder Screw (3), Hex Nut (2), and Shaft End Bushing (1). **(See Figure B.)**
4. Repeat Steps #1 through #3 to assemble a Grinding Wheel (4) on the **left** side of the Tool Grinder. **(See Figure B.)**
5. To assemble a Water Tray (22) on the **right** side of the Tool Grinder, slide the two mounting holes located on the Water Tray onto the two Water Tray Positioning Pins (24) located on the side of the Tool Grinder. **(See Figure B.)**
6. Repeat Step #5 to assemble a Water Tray (22) on the **left** side of the Tool Grinder. **(See Figure B.)**
7. To assemble a Work Support (25) on the **right** side of the Tool Grinder, align the two mounting holes located on the Work Support with the two threaded mounting holes located in the two Work Support Dials (16). Secure the Work Support to the two Work Support Dials, using two Work Support Fixing Screws (23), two Washers (15), and two Hex Nuts (14). **(See Figure B.)**
8. Repeat Step #7 to assemble a Work Support (25) on the **left** side of the Tool Grinder. **(See Figure B.)**
9. To Assemble the Miter Dial (54) on the **right** side Work Support (25). Slide the Miter Fixing Bracket (52) of the Miter Dial unit into the slot located midway in the Work Support. **(See Figure B.)**
10. Repeat Step #9 to assemble the Miter Dial (54) on the **left** side Work Support (25). **(See Figure B.)**
11. To assemble the Water Cup (60) on the **right** side of the Tool Grinder, slide the mounting hole located at the bottom of the Water Cup onto the Water Cup Set Pin (13). **(See Figure B.)**
12. Repeat Step #11 to assemble the Water Cup (60) on the **left** side of the Tool Grinder. **(See Figure B.)**

OPERATING INSTRUCTIONS

NOTE:

For further reference to the parts mentioned below, refer to the Parts List and Assembly Diagram on pages 10 and 11 of this manual.

BASIC PROCEDURES

1. To use the Water Cup (60), turn the Water Valve (61) counterclockwise all the way to its horizontal position. Fill the Water Cup about 3/4 full of water only. Then, depending on which Grinding Wheel (4) you will use, set the Water Cup upon the right side or left side Water Cup Set Pin (13). **(See Figure B.)**
2. The Work Support (25) is adjustable 0 to 45 degrees up or down. If necessary, turn the Locking Pole (20) counterclockwise to unlock the Work Support. Tilt the Work Support up or down until the desired angle of the grind is shown on the Work Support Dial (16). Then, turn the Locking Pole clockwise to lock the Work Support in position. **(See Figure B.)**
3. The Miter Dial (54) is adjustable 0 to 45 degrees to the right or left. To use the Miter Dial, slide the Miter Fixing Bracket (52) on the Miter Dial in the slot located midway in the Work Support (25). If necessary, turn the Locking Bolt (56) counterclockwise to unlock the Miter Dial. Turn the Miter Dial either right or left until the desired angle of grind is shown by the Indicator Pin (55). Then, turn the Locking Bolt clockwise to lock the Miter Dial in position. **(See Figure B.)**
4. Connect the Power Cord & Plug (69) to a 120 Volt, 3-prong electrical outlet. **(See Assy. Diagram.)**
WARNING! Avoid electrical shock. Keep lamp's electrical components and all grinder electrical components dry and free of water at all times.
5. The Lamp (40) features adjustable positioning. Turn on the Lamp, and adjust it for best viewing. **(See Figure B.)**
6. To turn on the Power Switch (50), press the **top Arrow** for "ON," and to turn the Grinding Wheel (4) in an **upward** direction. Or, press the **bottom Arrow** for "ON," and to turn the Grinding Wheel in a **downward** direction. (See Figure B.)
7. Allow the Grinding Wheel (4) sufficient time to come to full speed.
8. Turn the Water Valve (61) clockwise to release the flow of water onto the Grinding Wheel (4). Turn the Water Valve to adjust the flow of water. **(See Figure B.)**
CAUTION! Always be alert to the direction the Grinding Wheel (4) is spinning. See Power Switch (50) and note position of top and bottom arrow – showing upward or downward rotation.
9. Place the tool you are grinding against the Miter Dial (54), and slowly feed the tool into the revolving Grinding Wheel (4).
CAUTION! Keep hands away from the Grinding Wheel. Hold the tool firmly against the Miter Dial throughout the grinding process. Failure to do so may cause the tool to be propelled by the Grinding Wheel toward your body and/or into the machine.
10. Once the grinding process is completed, turn the Power Switch (50) to its **O** position to turn the machine "OFF."
11. Turn off the Lamp (40).
12. Disconnect the Cord & Plug (69) from its electrical power outlet.
13. Turn the Water Valve (61) counterclockwise all the way to its horizontal position to stop the flow of water.
14. Pull out to remove the Water Tray (22), and empty its contents.

To Grind A Tool

CAUTION! Do not turn on the Tool Grinder until all angle calibrations, and machine set-up procedures, are made and the grinding process is ready to proceed.

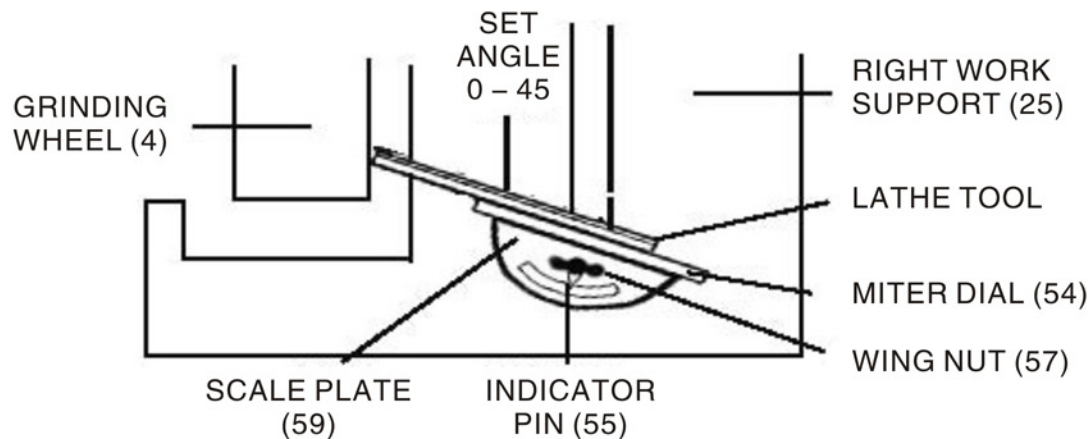

↑ FIGURES D

1. Loosen the Wing Nut (57), and place the tool against the edge of the Miter Dial (54). **(See Figure D.)**
2. Turn the Scale Plate (59) to the right or left until the desired angle of horizontal cut is shown by the Indicator Pin (55). Then, tighten the Wing Nut (57) to lock the Scale Plate in place.
NOTE: Make sure the end/side of the tool that is to be ground remains touching the side of the Grinding Wheel (4). **(See Figure D.)** Never attempt to sharpen a tool using the bottom circumference of the Grinding Wheel.
3. Loosen the Locking Pole (20), and tilt the Work Support (25) up or down until the desired angle of vertical cut is shown by the Work Support Dial (16). Then, tighten the Locking Pole in place.
4. Back the edge of the tool away from the face of the Grinding Wheel (4). Turn on the Tool Grinder and allow the Grinding Wheel to come to full speed. **(See Figure B.)**
5. While keeping the tool firmly held against the Miter Dial (54), slide the tool back and forth across the face of the Grinding Wheel until the angle of grind is completed on the first side of the tool. **(See Figures B, D.)**
6. The remaining three sides of the tool are ground the same way as the first side in Steps #2, #3, and #4, with the possible exception that each side may require a different angle of grind. If so, change the required angles by following Steps #2, #3 and #4. **(See Figure B, D.)**

INSPECTION, MAINTENANCE, AND CLEANING

CAUTION! ALWAYS disconnect the Tool Grinder from its electrical supply source before performing any inspection, maintenance, or cleaning procedures.

INSPECTION

Before each use, inspect the general condition of the Tool Grinder. Check for loose screws, misalignment, binding of moving parts, broken parts, loose or damaged electrical Power Cord, damaged Grinding Wheels, and any other condition that may affect its safe operation. If abnormal noise or vibration occurs during its use, disconnect the Tool Grinder from its electrical supply source immediately and have the problem corrected before further use.

Do not use damaged equipment.

MAINTENANCE

1. As a result of normal use, Grinding Wheels (4) may become cracked, grooved, rounded, chipped, out of true, or loaded with foreign material. Damaged Grinding Wheels should be immediately replaced. If the Grinding Wheel is replaced, make sure its rated speed is **at least as high as the rated RPM (3,400) of this Tool Grinder.**
2. Grinding Wheels (4) must be dressed to keep

them sharp and clean. As with sandpaper, Grinding Wheels become clogged with metal particles and dull with use. Dull Grinding Wheels rub the workpiece rather than cut, which results in increased friction, higher temperatures, and burned tools. A sharp Grinding Wheel will cut quickly with a “hissing” sound and with very little heat by comparison to a dull Grinding Wheel. A dull Grinding Wheel produces a “rapping” sound created by a loaded up area of metal particles on its cutting surface. A **Wheel Dressing Tool** (not provided) must be used to make the cutting edges of the abrasive grit on the Grinding Wheel sharp and clean. A Wheel Dresser sharpens and cleans by breaking off the clogged and dull outer layer of grit. **For information on the set-up and use of a particular Wheel Dresser consult the Wheel Dresser manufacturer's manual.**

CLEANING

1. If necessary, wipe with a damp cloth. You may use a mild detergent or non-flammable solvent.
2. Once clean, lubricate all moving parts, except the Grinding Wheels (4), with a light weight oil.
3. When storing, keep the Tool Grinder covered with a clean cloth cover.

PLEASE READ THE FOLLOWING CAREFULLY

THE MANUFACTURER AND/OR DISTRIBUTOR HAS PROVIDED THE PARTS DIAGRAM IN THIS MANUAL AS A REFERENCE TOOL ONLY. NEITHER THE MANUFACTURER NOR DISTRIBUTOR MAKES ANY REPRESENTATION OR WARRANTY OF ANY KIND TO THE BUYER THAT HE OR SHE IS QUALIFIED TO MAKE ANY REPAIRS TO THE PRODUCT OR THAT HE OR SHE IS QUALIFIED TO REPLACE ANY PARTS OF THE PRODUCT. IN FACT, THE MANUFACTURER AND/OR DISTRIBUTOR EXPRESSLY STATES THAT ALL REPAIRS AND PARTS REPLACEMENTS SHOULD BE UNDERTAKEN BY CERTIFIED AND LICENSED TECHNICIANS AND NOT BY THE BUYER. THE BUYER ASSUMES ALL RISK AND LIABILITY ARISING OUT OF HIS OR HER REPAIRS TO THE ORIGINAL PRODUCT OR REPLACEMENT PARTS THERETO, OR ARISING OUT OF HIS OR HER INSTALLATION OF REPLACEMENT PARTS THERETO.

PARTS LIST

Part	Description	Qty.	Part	Description	Qty.
1	Shaft End Bushing	2	36	Cord Bushing	1
2	Nut (M18)	2	37	Motor Base	1
3	Hex Socket Head Screw	8	38	Cord Clip Fixing Plate	1
4	Grinding Wheel	2	39	Cord Clip	1
5	Connection Plate	2	40	Lamp	1
6	Water Proof Rubber Washer	2	41	Spring Washer (8mm)	2
7	Hex Bolt (M6 x 25)	8	42	Hex Bolt (M8 x 20)	2
8	Philips Screw (M5 x 10mm)	16	43	Toothed Lock Washer (4mm)	1
9	Flat Washer (5mm)	17	44	Phillips Screw (M4 x 10mm)	3
10	Pointer I	2	45	Bottom Cover	1
11	Dial Set Pin	8	46	Nut (M5)	2
12	Wheel Cover	2	47	Capacitor Fixing Ring	1
13	Water Cup Set Pin	2	48	Capacitor	1
14	Nut (M8)	4	49	Switch Fixing Plate	1
15	Flat Washer (8mm)	4	50	Switch	1
16	Work Support Dial	4	51	Wave Spring	1
17	Flat Washer (10mm)	4	52	Miter Fixing Bracket	1
18	Lock Washer (10mm)	4	53	Straight Pin	1
19	Handle Moveable Pin Bushing	4	54	Miter Dial	1
20	Locking Pole	4	55	Indicator Pin	1
21	Handle Moveable Pin	1	56	Locking Bolt	1
22	Water Tray	2	57	Wing Nut	1
23	Work Support Fixing Screw	4	58	Nameplate Rivet (2.5 x 4mm)	2
24	Water Tray Positioning Pin	4	59	Scale Plate	1
25	Work Support	2	60	Water Cup	1
26	Pointer II	2	61	Valve	1
27	Adjusting Bushing	2	62	Water Pipe	1
28	Philips Screw (M6 x 25)	8	63	Right Motor End Cap	1
29	Lock Washer (6mm)	16	64	Hex Bolt (M5 x 30)	4
30	Left Motor End Cap	1	65	Spring Washer (5mm)	4
31	Bearing (180204)	2	66	Spring Washer (4mm)	2
32	Bearing Retaining Ring	2	67	Nut (M12 x 1)	1
33	Spring Type Straight Pin	2	68	Flat Washer (12mm)	1
34	Rotor	1	69	Cord & Plug	1
35	Stator	1			

NOTE: Some parts are listed and shown for illustration purposes only, and are not available individually as replacement parts.

ASSEMBLY DIAGRAM

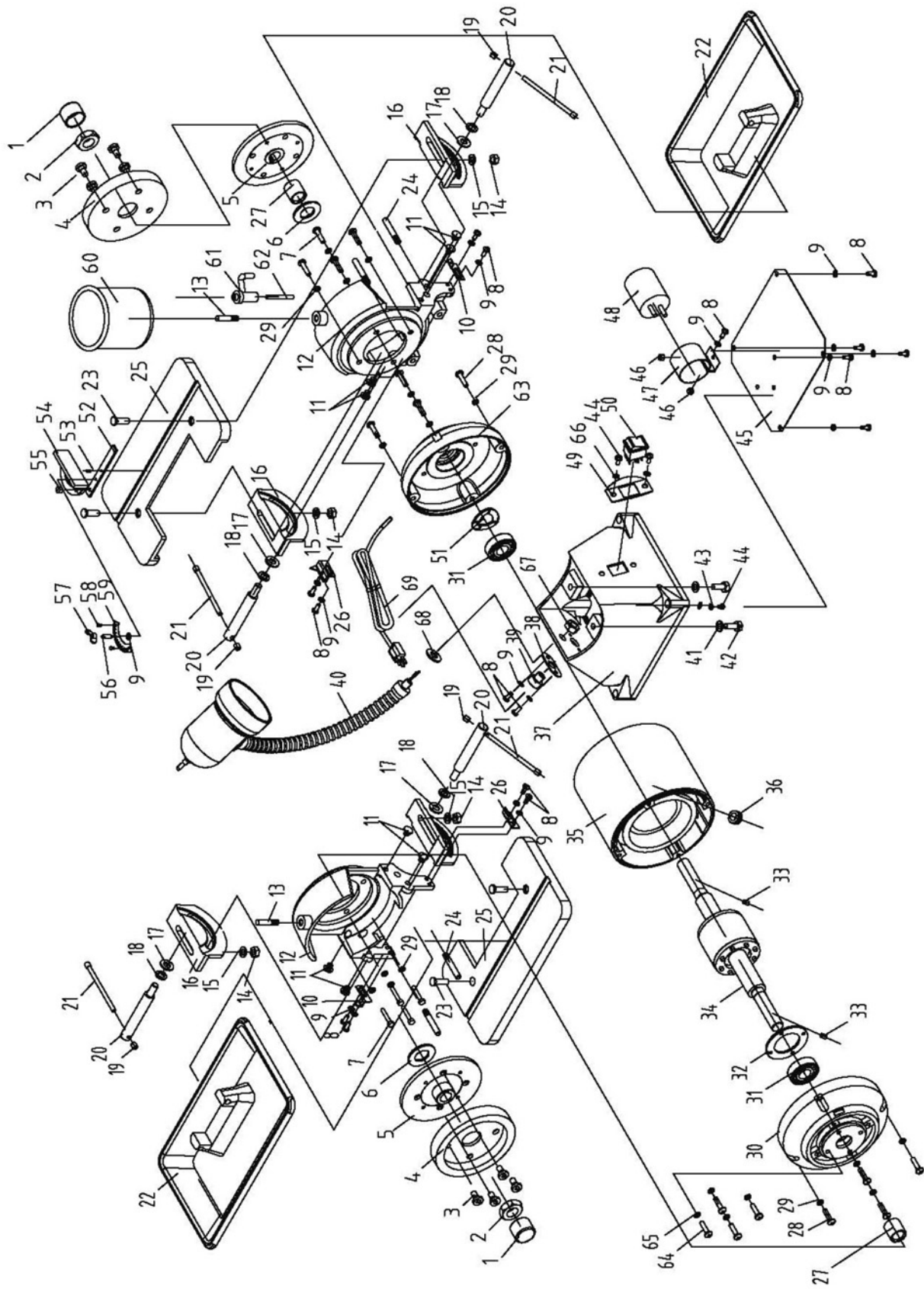



OTMT