

OTMT

RENCH LATHE

RENCH PRESS

OTMT

**Before Operating Your Tools,
Please Read This Instruction Carefully**



**ITEM NO.87-115-981
MODEL NO. # OT30280**

Content	
Important Safety Instructions	3-4
Specification	4
Features	4-5
Application	5
Operation	5-6
Operating Steps	6-7
Flow Chart	7
How To Mount Or Take Off The Shank And Drill Chuck	8
Parts Drawing I	9
Parts Drawing II	10
Parts List	11-13
Electric Diagram	14
Packing List	15

IMPORTANT SAFETY INSTRUCTIONS

Operator

Common sense and caution are factors which cannot be built into any product. These factors must be supplied by the operator. Please remember:

1. When using electric tools, machines or equipment, basic safety precautions should always be followed to reduce the risk of fire, electric shock, and personal injury.
2. Keep work area clean. Cluttered areas invite injuries.
3. Consider work area conditions. Do not use machines or power tools in damp, wet, or poorly lit locations. Do not expose equipment to rain, keep work area well lit. Do not use tools in the presence of flam-mable gases or liquids.
4. Keep children away, all children should be kept away from the work area.
5. Guard against electric shock. Prevent body contact with grounded surfaces such as pipes, radiators, ranges, and refrigerator enclosures.
6. Stay alert. Never operate if you are tired.
7. Do not operate the product if under the influence of alcohol or drugs. Read warning labels on prescriptions to determine if your judgment or reflexes might be impaired.
8. Do not wear loose clothing or jewelry as they can be caught in moving parts.
9. Wear restrictive hair covering to contain long hair.
10. Use eye and ear protection. Always wear.
11. Keep proper footing and balance at all times.
12. Do not reach over or across running machines.

Before operations

1. Be sure the switch is OFF when not in use and before plugging in.
2. Do not attempt to use inappropriate attachments in an attempt to exceed the tool's capacity. Approved accessories are available from the dealer or machine maker.
3. Check for damaged parts, before using any tool, any part that appears damaged should be carefully checked to determine that it will operate properly and perform its intended function.
4. Check for alignment and binding of all moving parts, broken parts or mounting fixtures and any other condition that may affect proper operation. Any part that is damaged should be prop early repaired or replaced by a qualified technician.
5. Do not use the tool if any switch does not turn off and properly

Operation

1. Never force the tool or attachment to do the work of a larger industrial tool. It is designed to do the job better and more safely at the rate for which it was intended.
2. Do not carry the tool by its power cord.
3. Always unplug the cord by the plug. Never yank the cord out of the wall.
4. Always turn off the machine before unplugging.

If There Is Any Question About A Condition Being Safe Or Unsafe, Do Not Operate The Tool!

Grounding Instructions

This machine has a three-prong plug, the third prong is the ground. Plug this cord only into a three-prong receptacle. Do not attempt to defeat the protection the ground wire provides by cutting off the round prong. Cutting off the ground will result in a safety hazard and void the warranty.

Do Not Modify The Plug In Any Way. If You Have Any Doubt, Call A Qualified Electrician.

SPECIFICATION:

Max. drilling capacity:	1.18"(30mm)
Max. tapping capacity:	0.55"(M14)
Max. travel of spindle:	3.94"(100mm)
Spindle bore taper (Morse):	MT#3
Spindle speed	100-1800 R.P.M
Distance from spindle axis to generating line of column	11.02"(280mm)
Max. distance from spindle nose to working surface of work table	18.11"(460mm)
Max. distance from spindle nose to working surface of base plate	36.61"(930 mm)
Dimension of worktable surface	15.75"*13.78"(400*350mm)
Diameter of column	4.33"(110mm)
Overall height	68.90" (1750mm)
Motor output power	1500W
Worktable 'T' slot size	0.55" (14mm)
Overall size(L*W*H)	29.53"*21.65"*71.65"(750*550*1820mm)
Packing size:(L*W*H)	33.46"*23.62"*78.74"(850*600*2000mm)
Gross weight	361kg
Net weight	321kg
Effective working area of table	400×350mm(15.75"X13.78")
Motor output power	1500W

FEATURES

1	Cover
2	Spindle speed readout
3	Operation panel
4	Feeding depth readout
5	Spindle
6	Safety guard
7	Worktable
8	Locking handle
9	Hose
10	Base
11	Lift handle
12	Lift stock
13	Column
14	Rack
15	Feeding handle
16	Electrical box

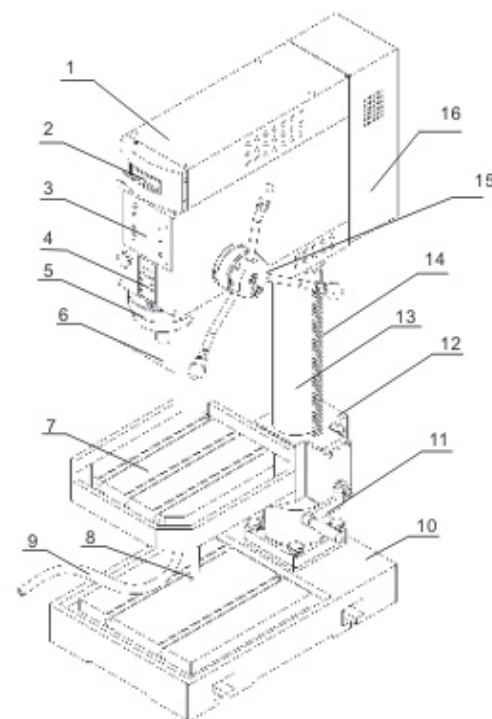

APPLICATION

This drilling machine is both for drilling and tapping, widely used in different places. Fine exterior, wide range of speed and easy to use.

Designed for industrial usage, drilling, tapping, reaming, steps and mill plane with metal and other material.

OPERATION

1. Before starts to use this machine, operator should go through the instructions carefully so as to acquaint with the construction of the machines, the functions of the various controls and also the driving systems.
2. Before putting the machine into operation, check the working table tightness on column, examine the condition of movement of spindle sleeve and the condition of electrical equipment.
3. The height of worktable (7) is adjustable. Before adjusts, loosen the clamping lever, if the worktable (7) needs upward, rotate the lift handle (11) in clockwise, or, rotate it in anti-clockwise. When the worktable goes up or down to the end, please do not turn the lift handle (11) any more, avoid the impairment of the machine.
4. Press the handle (15), the spindle (5) going down, the depth was showed at digital readout (4).

5. This machine with a setting drilling depth function (the max. depth can be set is 80mm). Here are the steps of setting drilling depth (see drawing below): put the dial (3) to position "0" align at the zero mark on label (2), rotate the dial(3) clockwise to the depth demanded, tighten the knurling handle(1) by hand to lock the dial.

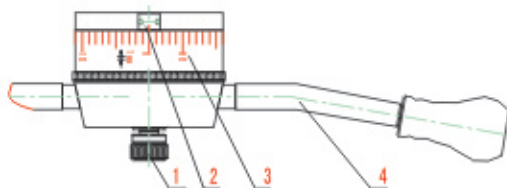

6. This machine uses touching button (see operation panel below), operating steps refer to the flow chart.

Spindle speed readout >>

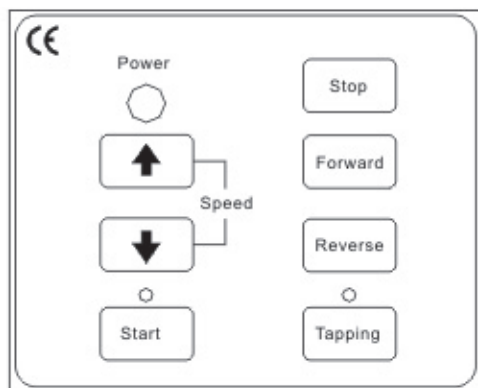

^ Operation panel

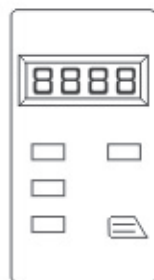

Spindle depth readout ^

OPERATING STEPS

1. Insert the electric plug into its socket. Turn the power switch to 'I' position, the power indicator lights (green).
2. Release the Emergency stop switch by turning the round head of the switch, the Spindle speed readout shows '0000'.
3. Press 'Start' button on the touching panel, the light above 'Start' button lights, spindle speed readout shows '0100 FORWARD'. Notice: '0100' is the lowest speed of this machine
4. Press '↑' button, speed increase, press '↓' button, speed decrease.
5. Press 'Stop' button, spindle stop running, if press 'Start' button now, spindle runs to the speed last setting automatically.



6. Press the "Tapping" button, the light above the 'Tapping' button lights. This means now is the 'Tapping mode', 'Forward' and 'Reverse' buttons are unavailable
7. Taping: the highest speed under 'Tapping mode' is 500rpm. Press the bottom end of the handle (total 3 pcs), then the spindle running direction is reverse. Then press again is forward. (refer to the drawing right)

Notice:

UThe highest spindle speed in REVERSE direction is a half of when in FORWARD direction. After using should turn the power switch to position '0' and pull out the plug from socket.

FLOW CHART

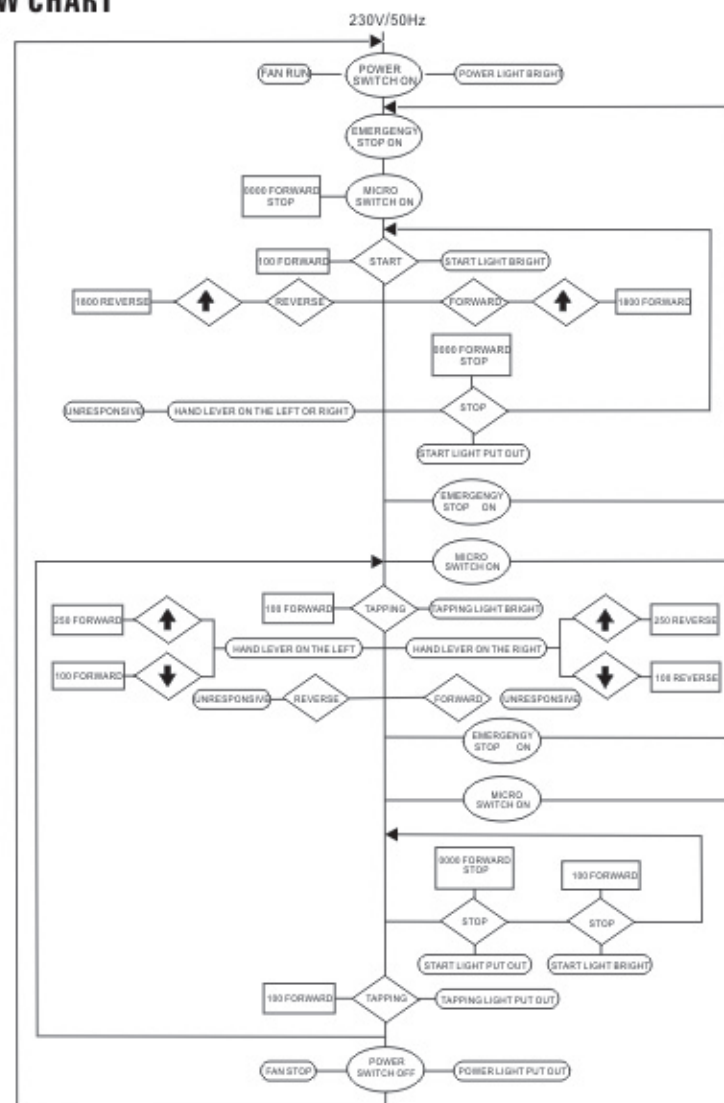

HOW TO MOUNT OR TAKE OFF THE SHANK AND DRILL CHUCK

TAKE OFF

If the shank and drill chuck is mounted on the machine, rotate the small hand wheel (1) 180°, the rotor shaft (2) will turn over and almost touch the block (3). Holding the drill chuck and push the spindle feeding handle upward (do not need too much strength), shank and drill chuck goes out.

MOUNT

Rotate the small hand wheel (1) 180°, the rotor shaft (2) turns over, just put the shank and drill chuck into spindle hole.

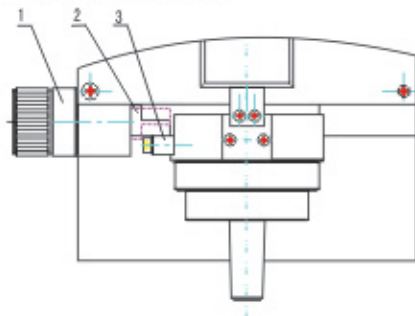

PARTS DRAWING I

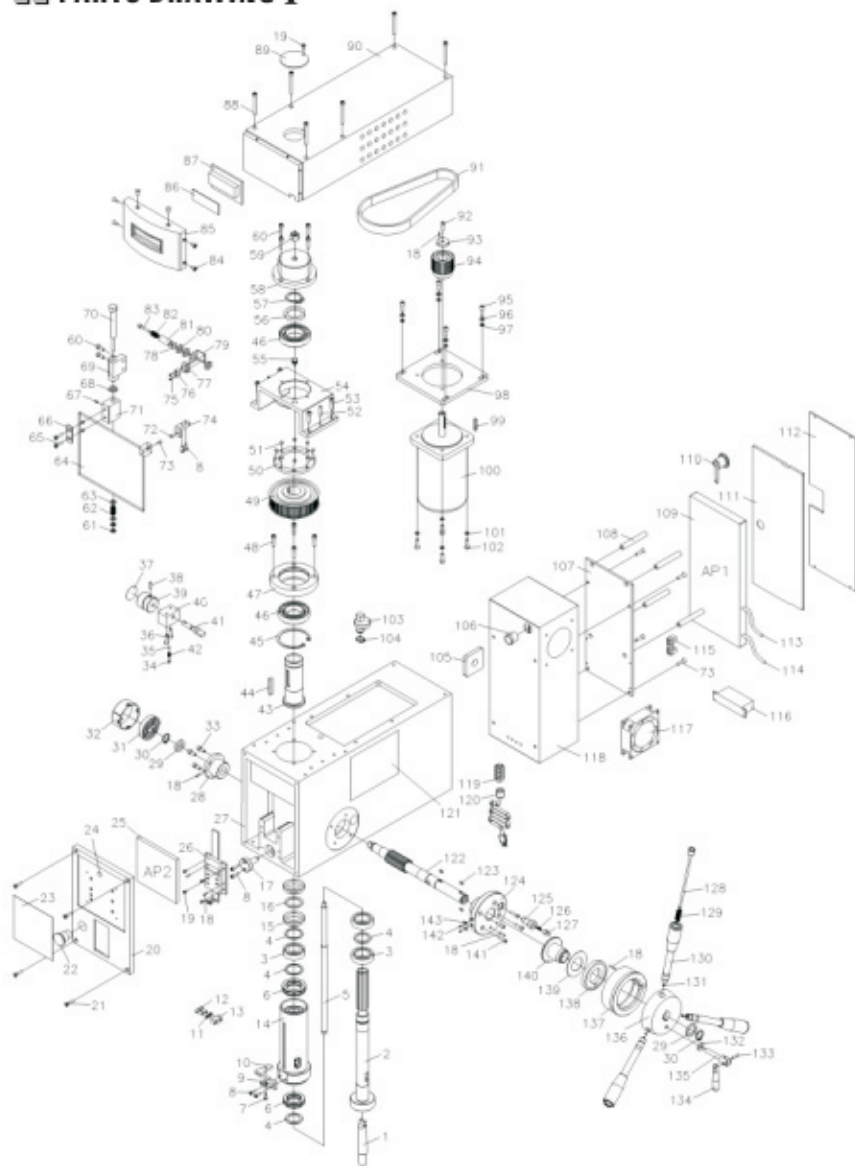

PARTS DRAWING II

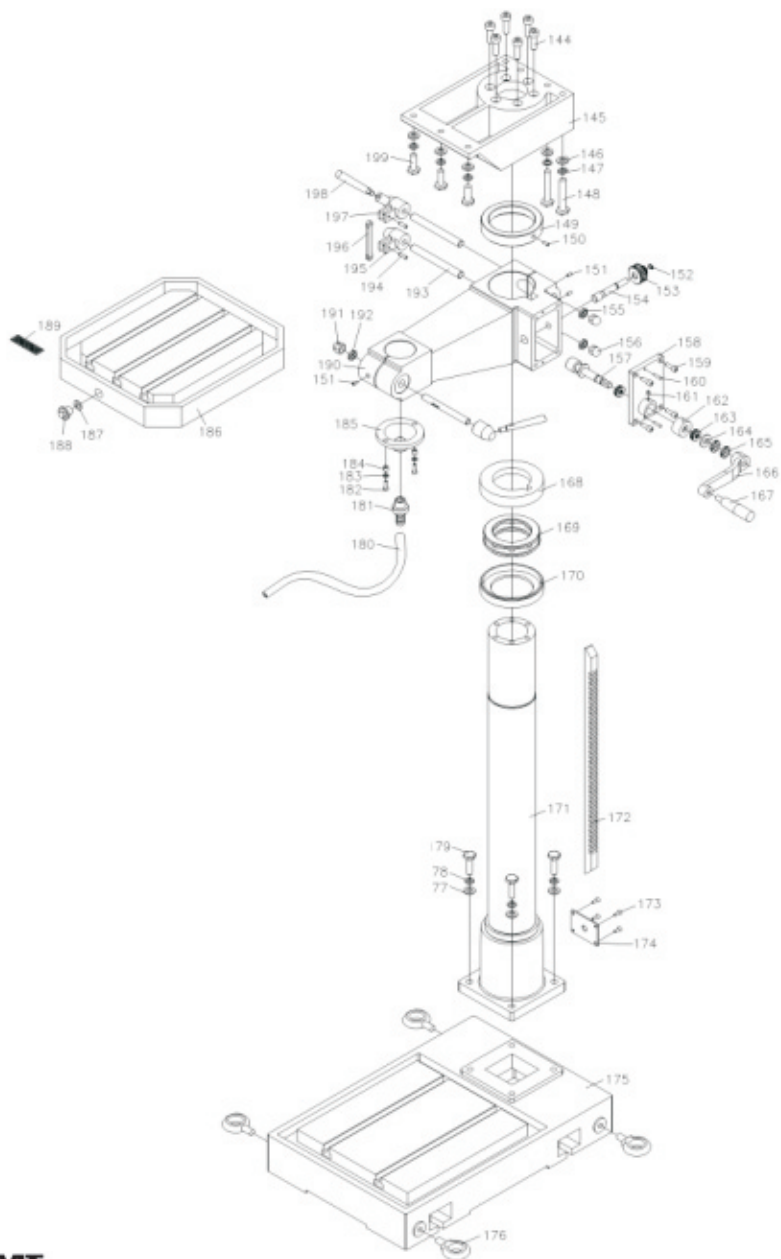

PARTS LIST

No.	Description	Qty.	No.	Description	Qty.
1	Taper shank	1	40	Rotate shaft fastens block	1
2	Spindle	1	41	Small rotate shaft	1
3	Bearing 61907-LS	3	42	Spring 5*5	1
4	Washer(I)	4	43	Spline sleeve	1
5	Tip shaft	1	44	Key 8*32	1
6	Bearing 51107	2	45	Check ring 62	1
7	Cap screw M4*8	1	46	Bearing 6007-RS	2
8	Cap screw M4*10	6	47	Flange cover	1
9	Display Fixing block	1	48	Cap screw M4*14	4
10	Display Fixing adjust block	1	49	Spindle pulley	1
11	Small washer 4	2	50	Alnico fastness ring	1
12	Cap screw M4*8	2	51	Alnico	8
13	Support block	1	52	Taper pin 6*22	2
14	Spindle sleeve	1	53	Cap screw M6*25	4
15	Small round nut M30*1.5	2	54	Bracket	1
16	Liming washer 30	1	55	Survey speed setting	1
17	Site key	1	56	Washer(II)	1
18	Spring pin 3*10	6	57	Check ring 35	1
19	Screw M3*10	7	58	Flange cover	1
20	Switch label	1	59	Nut M12	1
21	Screw M4*16	4	60	Screw M5*16	6
22	Emergency stop switch	1	61	Nut M12	2
23	Switch label film	1	62	Compress spring 1.2*8*22	1
24	Green lamp	1	63	Round washer 6	2
25	PC Board	1	64	Protect cover	1
26	Display assembly	1	65	Screw M4*12	2
27	Spindle box	1	66	Impact block	1
28	Left support flange	1	67	Screw M5*6	1
29	Adjust washer	2	68	Round washer 10	1
30	Check ring 19	2	69	Rotate shaft fixed body	1
31	Spiral spring	1	70	Rotate shaft	1
32	Encloser of check spring	1	71	Protect cover fixed block	1
33	Cap screw M4*18	3	72	Magnet	1
34	Screw M6*5Steel ball 5	1	73	Screw M5*12	5
35	Steel ball 5	1	74	Protect cover keep off block	1
36	Screw M4*25	2	75	Screw M2*20	2
37	Control label	1	76	Small mat block	2
38	Set screw M5*12	1	77	Micro switch	1
39	Knurling small handle wheel	1	78	O airproof ring	1

No.	Description	Qty.	No.	Description	Qty.
79	Switch fixed support	1	119	Lock connect	1
80	Nut M12	3	120	Power line	1
81	Small bolt	1	121	Main label	1
82	Compress spring 0.5*5*10	1	122	Gear shaft	1
83	Small tip shaft	1	123	Key 5*10	3
84	Screw M4*8	6	124	Right Support flange	1
85	Speed show face plate	1	125	Change switch seat	1
86	Keep off piece	1	126	Compress spring 0.6*5*22	1
87	Rotate speed display	1	127	Small shaft	1
88	Screw M5*50	6	128	Joy stick assembly	3
89	Cover	1	129	Compress spring 0.9*8*24	3
90	Upper cover	1	130	Handle assembly	3
91	Timing belt L635-25	1	131	Check ring 6	3
92	Screw M8*16	1	132	Lock adjust block	1
93	Compress washer	1	133	Round pin 4*15	1
94	Motor pulley	1	134	Lock handle	1
95	Screw M8*16	4	135	Lock screw shaft	1
96	Washer 8	4	136	Handle seat	1
97	Spring washer 8	4	137	Dial	1
98	Motor fixed plate	1	138	Lock block	1
99	Key 6*25	1	139	Insulate pieces	1
100	Brushless motor	1	140	Transmit electricity assembly	1
101	Spring washer 8	4	141	Screw M5*14	4
102	Screw M8*20	4	142	Rivet 2*4	2
103	Partiality shaft	1	143	O position label	1
104	Check ring	1	144	Screw M10*30	6
105	Power switch	1	145	Bracket	1
106	Guard ring	1	146	Washer 10	7
107	Electric box soleplate	1	147	Spring washer 10	7
108	Pad	4	148	Bolt M10*105	4
109	PC Board Ap1	1	149	Tighten circle	1
110	Door lock	1	150	Screw M5*16	1
111	Electric box door	1	151	Screw M6*10	3
112	Electric box cover	1	152	Check ring 18	1
113	Connect line I	1	153	Worm wheel	1
114	Connect line II	1	154	Small shaft	1
115	Fuse box	1	155	Nut M16	2
116	Filter	1	156	Cap nut M16	2
117	Fan	1	157	Rise drop worm	1
118	Elertric box	1	158	Worm seat	1

No.	Description	Qty.	No.	Description	Qty.
159	Screw M6*16	4	180	Transmit tube	1
160	Round pin B5*25	2	181	Coolant tie-in	1
161	Oil cup 6	1	182	Screw M4*16	2
162	Bush	1	183	Washer 4	2
163	Bearing 51103	2	184	Washer	2
164	Washer	1	185	Filler	1
165	Small round nut M16*1.5	2	186	Worktable	1
166	Rotate handle	1	187	Airproof mat	1
167	Rotate handle M10*80	1	188	Plug	1
168	Move circle	1	189	Escape unpunished	1
169	Bearing 51124	1	190	Rise drop sleeve	1
170	Bearing seat	1	191	Nut M12	1
171	Fuselage	1	192	Cap nut M12	1
172	Rack	1	193	Rise drop sleeve bolt	2
173	Screw M4*10	4	194	Round pin D8*26	2
174	Fuselage cover	1	195	Connect seat	1
175	Base	1	196	Connect shank	1
176	Flying rings screw M12	4	197	Connect shank seat	1
177	Washer 14	4	198	Straight handle BM12*125	1
178	Spring washer 14	4	199	Bolt M10*30	3
179	Bolt M14*50	4			

ELECTRIC DIAGRAM

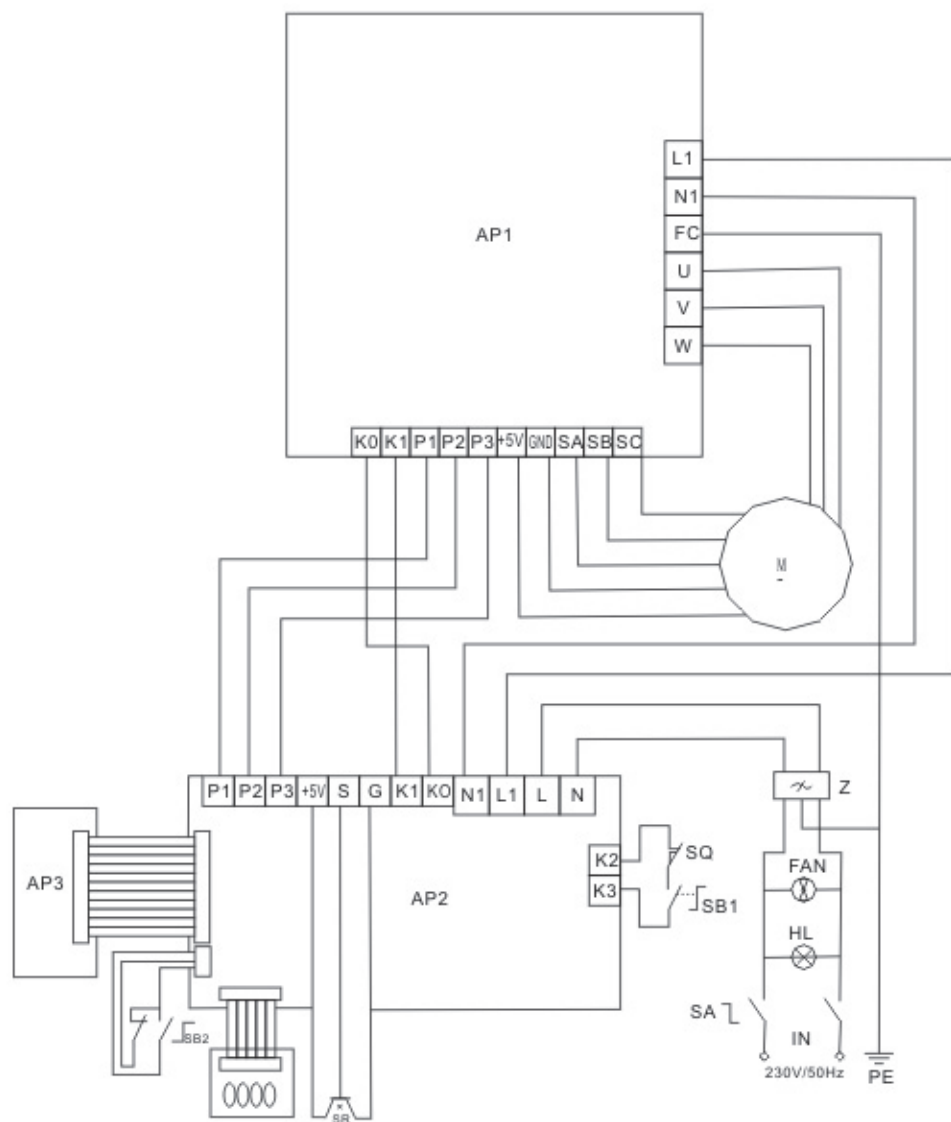

PACKING LIST

No.	Description	Qty.
1	Drill chuck and key B18/JT6	1
2	L Hex. Wrench S:3,4,5,6,8	5
3	Tilted wedge	1
4	Screw driver 3"	1
5	Oil can	1
6	Fuse	1
7	Double end wrench: 14*17	1
8	Manual	1