

# Operating manual

Version 1.3.3

## Lathe

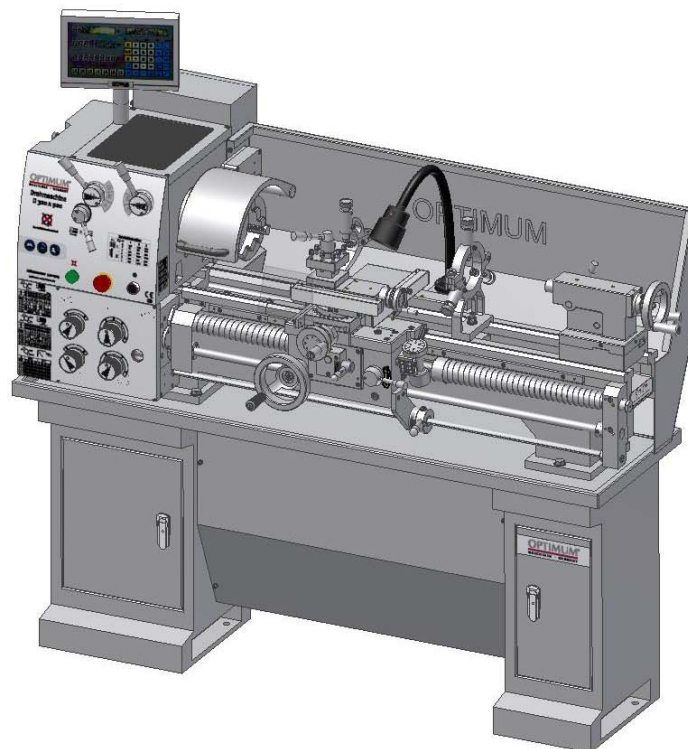

Illustr. 0-1: D360x920 DPA

- D320 x 920**
- D320 x 920 DPA**

**Keep for future reference!**

## Table of contents

### Preface

We thank you very much that you have decided for the Lathe D320 x 920 ; D320 x 920 DPA made by Optimum.

The illustrations of the lathe might in some details deviate from the illustrations of this operating manual but this will have no influence on the operation of the lathe.

Any changes in the construction, equipment and accessories are reserved in terms of the enhancement. Therefore no claims may be derived from the indications and descriptions. Errors excepted !

We wish you lots of success !

### 1 Safety

1.1	Safety warnings (warning notes) .....	6
1.1.1	Classification of hazards .....	6
1.1.2	Further ideograms .....	7
1.2	Proper use .....	7
1.3	Possible dangers caused by the lathe .....	8
1.4	Qualification of employees .....	9
1.4.1	Target group .....	9
1.4.2	Authorized persons .....	9
1.4.3	Obligations of the operator .....	9
1.4.4	Obligations of the user .....	9
1.4.5	Additional qualification requirements .....	10
1.5	User's position .....	10
1.6	Safety measures during operation .....	10
1.7	Safety devices .....	10
1.7.1	Lockable main switch .....	11
1.7.2	EMERGENCY-STOP .....	11
1.7.3	Lathe chuck protection with position switch .....	12
1.7.4	Protective cover with safety switch .....	12
1.7.5	Protective cover feed shaft, feed shaft clutch .....	12
1.7.6	Prohibition, warning and mandatory labels .....	13
1.8	Safety check .....	13
1.9	Personal protective equipment .....	14
1.10	Safety during operation .....	14
1.11	Safety during maintenance .....	15
1.11.1	Switching off and securing the lathe .....	15
1.11.2	Use of lifting equipment .....	15
1.11.3	Mechanical maintenance work .....	16
1.12	Accident report .....	16
1.13	Electrical system .....	16

### 2 Technical Data

2.1	Power connection .....	17
2.2	Machine data .....	17
2.3	Dimensions .....	18
2.4	Work area .....	18
2.5	Environmental conditions .....	18
2.6	Operating material .....	18
2.7	Emissions .....	19
2.8	Dimensions, installation plan D320x920 .....	20
2.9	Dimensions, installation plan D320x920 DPA .....	21

### 3 Assembly



3.1	Delivery volume .....	22
3.2	Optional lathe accessories .....	22
3.3	Transport .....	23
3.4	Storage .....	24
3.5	Installation and assembly .....	24
3.5.1	Requirements of the installation site .....	24

3.6	Load end position.....	25
3.6.1	Installation.....	26
3.6.2	Anchoring-free assembly.....	26
3.6.3	Anchored assembly.....	27
3.7	First use.....	27
3.7.1	Cleaning and greasing.....	27
3.7.2	Visual inspection.....	27
3.7.3	Functional check.....	27
3.7.4	Power connection.....	27
3.7.5	Functional test.....	30
<b>4</b>	<b>Operation</b>	
4.1	Safety.....	31
4.2	Control and indicating elements.....	31
4.2.1	Overview of control elements.....	32
4.2.2	Overview of indicating elements.....	33
4.2.3	Control elements.....	33
4.3	Speed adjustment.....	34
4.3.1	Speed table D 320 x 920.....	34
4.3.2	Position change of the V-belt positions.....	34
4.3.3	Turning direction.....	35
4.4	Feed.....	35
4.4.1	Rate of feed.....	36
4.4.2	Feed direction.....	36
4.5	Tool holder.....	36
4.6	Switching the lathe on.....	37
4.7	Head spindle seat.....	37
4.7.1	Lathe chuck.....	38
4.7.2	Mounting workpiece holders.....	38
4.8	Mounting of rests.....	39
4.8.1	Movable and steady rests.....	39
4.9	Bed insert.....	39
4.9.1	Feed table.....	40
4.9.2	Table for thread cutting.....	41
4.9.3	Replacement, change of position of the change gears.....	42
4.9.4	Threading gauge.....	43
4.10	Tailstock.....	44
4.10.1	Cross-adjustment of the tailstock.....	44
4.11	General working notes.....	45
4.11.1	Straight turning.....	45
4.11.2	Facing and recesses.....	45
4.11.3	Fixing the lathe saddle.....	45
4.11.4	Turning between centers.....	46
4.11.5	Turning short tapers with the compound slide.....	46
4.11.6	Thread-cutting.....	47
4.11.7	Coolant.....	47
4.12	Mounting of optional accessories.....	47
4.12.1	Universal collet chucking attachment.....	48
4.12.2	Draw-in collet chuck Camlock D 1-4" 5C.....	48
4.12.3	Positioning impact position with fine adjustment.....	48
4.13	Turning Speeds & Feeds.....	49
4.14	Recommended Cutting Speeds in Feet per Minute for Turning Ferrous and Nonferrous Metals*.....	49
4.15	Calculating RPM.....	51
4.15.1	Selecting Feed per Revolution.....	52
4.15.2	Recommended Feed Rate Selection in Inches Per Revolution for Turning.....	53
<b>5</b>	<b>Cutting speeds</b>	
5.1	Choosing the right cutting speed.....	54
5.2	Influences on the cutting speed.....	54
5.3	Example for the determination of the required rotation speed on your lathe.....	54
5.4	Cutting speed table.....	55
<b>6</b>	<b>Maintenance</b>	
6.1	Safety.....	58

6.1.1	Preparation.....	58
6.1.2	Restarting.....	58
6.2	Inspection and maintenance.....	59
6.3	Repair.....	66
<b>7</b>	<b>Spare parts - D320x920, D320x920 DPA</b>	
7.1	Drawing spare parts headstock gear 1-6.....	67
7.2	Drawing spare parts headstock gear 2-6.....	68
7.3	Drawing spare parts headstock gear 3-6.....	69
7.4	Drawing spare parts headstock gear 4-6.....	70
7.5	Drawing spare parts headstock gear 5-6.....	71
7.6	Drawing spare parts headstock gear 6-6.....	72
7.6.1	Spare parts list headstock gear.....	73
7.7	Drawing spare parts change gear.....	75
7.7.1	Spare parts list change gear.....	75
7.8	Drawing spare parts feed gear 1-6.....	76
7.9	Drawing spare parts feed gear 2-6.....	77
7.10	Drawing spare parts feed gear 3-6.....	78
7.11	Drawing spare parts feed gear 4-6.....	79
7.12	Drawing spare parts feed gear 5-6.....	80
7.13	Drawing spare parts feed gear 6-6.....	81
7.13.1	Spare part list feed gear.....	82
7.14	Drawing spare parts apron 1-3.....	84
7.15	Drawing spar parts apron 2-3.....	85
7.16	Drawing spare parts apron 3-3.....	86
7.17	Drawing spare parts threading gauge.....	87
7.17.1	Spare part list apron.....	88
7.18	Drawing spare parts lathe compound slide.....	90
7.18.1	Spare part list compound slide.....	91
7.19	Drawing spare parts lathe compound slide.....	92
7.19.1	Spare part list compound slide.....	93
7.20	Drawing spare parts lathe bed 1-2.....	94
7.21	Drawing spare parts lathe bed 2-2.....	95
7.21.1	Spare part list lathe bed.....	96
7.22	Drawing spare parts machine substructure.....	98
7.22.1	Spare part list machine substructure.....	98
7.23	Drawing spare parts tailstock.....	99
7.23.1	Spare part list tailstock.....	100
7.24	Drawing spare parts steady rest.....	101
7.24.1	Spare part list steady rest.....	102
7.25	Drawing spare parts movable rest.....	103
7.25.1	Spare part list steady rest.....	103
7.26	Drawing spare parts chuck protection.....	104
7.26.1	Spare parts chuck protection.....	104
7.27	Drawing spare parts chip protection.....	105
7.28	Drawing spare parts chip protection D320 DPA.....	105
7.28.1	Spare parts chip protection.....	106
7.29	Drawing spare parts machine lamp.....	107
7.29.1	Spare parts machine lamp.....	107
7.30	Spare parts drawing D320x920, D320x920 DPA, DPA2000, measuring gib.....	108
7.30.1	Spare parts DPA2000, measuring gib.....	108
7.31	Wiring diagram.....	109
7.31.1	Spare part list electric components.....	110
<b>8</b>	<b>Malfunctions</b>	
<b>9</b>	<b>Appendix</b>	
9.1	Copyright.....	113
9.2	Terminology/Glossary.....	113
9.3	LIMITED WARRANTY.....	114
<b>10</b>	<b>Index</b>	

# 1 Safety

## Glossary of symbols

	gives further advice
	calls on you to get in action
	enumeration

This part of the operating manual

- explains the meaning and use of the warning references contained in the operating manual,
- explains how to use the lathe properly,
- highlights the dangers that might arise for you or others if these instructions are not obeyed,
- tells you how to avoid dangers.

In addition to this operating manual please observe

- applicable laws and regulations,
- legal regulations for accident prevention,
- the prohibition, warning and mandatory signs as well as the warning notes on the lathe.

Consult OSHA, state and local regulations in order to determine compliance, danger and risks to the operator.



**ALWAYS KEEP THIS DOCUMENT CLOSE TO THE LATHE FOR FUTURE REFERENCE.**

### INFORMATION

If you are unable to solve a problem using this manual, please contact us for advice:

Exclusive USA Agent

LDS Industries, LLC

930 W. National Ave.



Addison, IL 60101

Tel.: 1-630-785-6437

## 1.1 Safety warnings (warning notes)

### 1.1.1 Classification of hazards

We classify the safety warnings into various levels. The table below gives an overview of the classification of symbols (ideogram) and warning signs for each specific danger and its (possible) consequences.

ideogram	warning alert	definition / consequences
	<b>DANGER!</b>	Threatening danger that will cause serious injury or death to people.
	<b>WARNING!</b>	Risk: A danger that might cause serious injury or death to a person.
	<b>CAUTION!</b>	Danger or unsafe procedure that might cause injury to people or damage to property.
	<b>ATTENTION!</b>	Situation that could cause damage to the lathe and to the product and other types of damages. No risk of injury to people.
	<b>INFORMATION</b>	Application advice and other important or useful information and notes. No dangerous or harmful consequences for people or objects.

In the case of specific dangers, we replace the pictogram

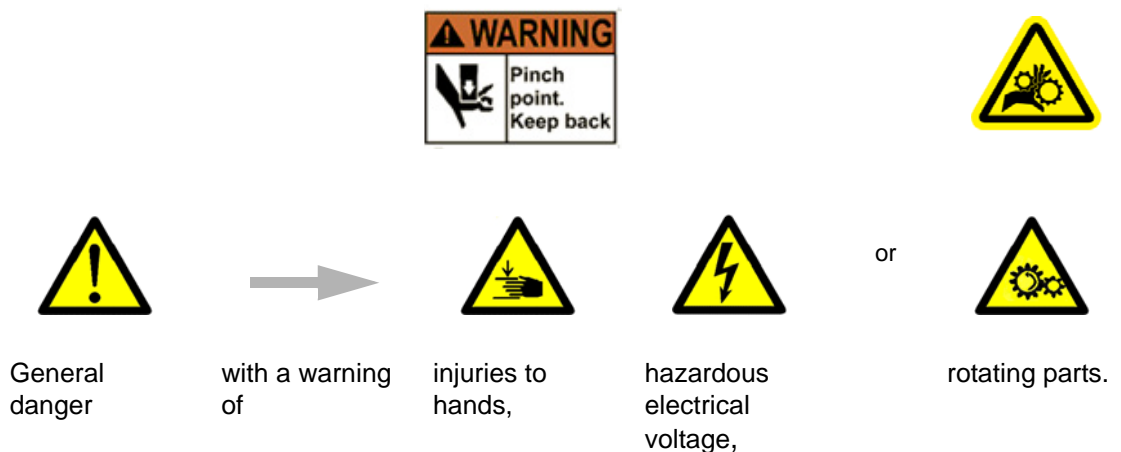

## 1.1.2 Further ideograms



Activation forbidden!



Pull the main plug!



Use safety glasses!



Use ear protection!



Use protective gloves!



Use protective boots!



Wear a safety suit!



Only switch in standstill!



Protect the environment!



Contact address

## 1.2 Proper use



### WARNING!

**In the event of improper use, the lathe**

- will endanger personnel,
- will endanger the lathe and other material property of the operator,
- may affect proper operation of the lathe.

The lathe is designed and manufactured to be used in environments where there is no potential danger of explosion.

The lathe is designed and manufactured for straight turning and facing round or regular formed three-, six or twelve-square workpieces in cold metal, castings and plastics or similar material that do not constitute a health hazard or do not create dust, such as wood. The lathe must only be installed and operated in a dry and ventilated place.

If the lathe is used in any way other than described above, modified without authorization of Optimum, then the lathe is being used improperly.

We do not take liability for damage caused by improper use.

We would like to stress that any modifications to the construction, or technical or technological modifications that have not been authorised by Optimum will also render the guarantee null and void.

It is also part of proper use that

- the maximum values of the lathe are complied with,
- the operating manual is observed,
- inspection and maintenance instructions are observed.

☞ „Technical Data“ on page 17

In order to achieve optimum cutting performance, it is essential to choose the right turning tool, feed, tool pressure, cutting speed and coolant.



### WARNING!

**Very serious injury due to improper use.**

**It is forbidden to make any modifications or alternations to the operating values of the lathe. They could endanger personnel and cause damage to the lathe.**

### 1.3 Possible dangers caused by the lathe

The lathe has undergone a safety inspection. The construction and design are state of the art. Nevertheless, there is a residual risk as the lathe operates with

- high revolutions,
- rotating parts,
- electrical voltage and currents.

We have used construction resources and safety techniques to minimize the health risk to persons resulting from these hazards.

If the lathe is used and maintained by employees who are poorly qualified, then there might be a risk resulting from incorrect operation and unsuitable maintenance of the lathe.



#### INFORMATION

All persons involved in the assembly, commissioning, operation and maintenance must

- be duly qualified,
- strictly follow this operating manual.

Due to improper use

- there is a risk for the employee,
- the lathe and further property might be endangered,
- the function of the lathe could be affected.

Always disconnect the lathe if cleaning or maintenance work is being carried out.



#### WARNING!

**The lathe may only be used with the safety devices activated.**

**Disconnect the lathe immediately whenever you detect a failure in the safety devices or when they are not mounted!**

**All additional installations carried out by the operator must incorporate the safety devices prescribed.**

**This is your responsibility being the operator!**

 **„Safety devices“ on page 10**



## 1.4 Qualification of employees

### 1.4.1 Target group

This manual applies to

- the operators,
- the users,
- the maintenance staff.

Therefore, the warning notes refer to both operation and maintenance of the lathe.

Determine clearly and make a permanent decision in who will be responsible for the different activities on the lathe (operation, maintenance and repair).



Vague and unclear assignment of responsibilities constitute a safety hazard!

Always disconnect the main plug of the lathe and secure the main switch by a lock. This will prevent it from being used by unauthorized persons.

### 1.4.2 Authorized persons



#### **WARNING!**

**Incorrect use and maintenance of the lathe constitutes a danger for the staff, objects and the environment.**

**Only authorized persons may operate the lathe!**

Persons authorized to operate and maintain should be trained technical staff and instructed by the ones who are working for the operator and for the manufacturer.

### 1.4.3 Obligations of the operator

The operator must instruct the staff at least once a year on

- all safety standards that apply to the lathe,
- the operation,
- accredited technical guidelines.

The operator must also

- check the knowledge of the staff,
- document training / instructions,
- require the staff to confirm participation in training / instructions by means of a signature,
- check that the staff is aware of safety and dangers in the workplace and that they observe the operating manual.

### 1.4.4 Obligations of the user

The user must

- have read and understood the operating manual,
- be familiar with all safety devices and regulations,
- be able to operate the lathe.

### 1.4.5 Additional qualification requirements

For work on electrical components or equipment there are additional requirements:

- This work shall only be carried out by a qualified electrician or a person working under the instructions and supervision of a qualified electrician.

Before carrying out work on electric components or operating units, the following measures must be taken in the order given.

- disconnect main electrical power,
- ensure that the lathe cannot be turned on again,
- check that there is no voltage.

### 1.5 User's position

The user must stand in front of the lathe.

### 1.6 Safety measures during operation



#### CAUTION!

**Risk due to inhaling of health hazardous dusts and mist.**

Dependent on the material which need to be processed and the used auxiliaries dusts and mist may be caused which might impair you health.

**Make sure that the generated health hazardous dusts and mist are safely sucked off at the point of origin and is dissipated or filtered from the working area. Use an appropriate suction unit.**



#### CAUTION!

**Risk of fire and explosion by using flammable materials or cooling lubricants.**

**Take additional preventive measures in order to safely avoid health hazards before processing flammable materials (e.g. aluminum, magnesium) or before using flammable additives (e.g. alcohol).**



#### CAUTION!

**Risk of winding-up or cutting damages when using hand tools.**

**The machine is not designed for the use of hand tools (e.g. emery cloth or files). It is forbidden to use any hand tools on this machine.**

### 1.7 Safety devices

Operate the lathe only with properly functioning safety devices.

Stop the lathe immediately if there is a failure in the safety device or if it is not functioning for any reason.

It is your responsibility!

If the safety device has been activated or has failed, the lathe must only be operated again when

- the cause of the failure has been removed,
- you have made sure that there is no resulting danger for persons or objects.



**WARNING!**

If you bypass, remove or override a safety device in any other way, you are endangering yourself and other persons working on the lathe. The possible consequences are:

- damage as a result of components or parts of components flying off at high speed,
- contact with rotating parts,
- fatal electrocution,
- pulling-in of clothes.



**WARNING!**

The separating protective equipment which is made available and delivered together with the machine is designed to reduce the risk of workpieces or fractions of them which being expelled, but not to remove them completely.

The lathe includes the following safety devices:

- a lockable main switch,
- an EMERGENCY-STOP button,
- a lathe chuck guard with position switch,
- a protective cover on the headstock with position switch,
- safety screws for the Camlock bolts on the workpiece holder,
- a slip chuck in the feed rod,
- a protective cover for the guide spindle (coil spring).

### 1.7.1 Lockable main switch

It is possible to secure the lockable main switch with a padlock at the position "0" against switching on by mistake or unauthorized switching on.

When the main switch is switched off, the power supply to the machine is completely interrupted.

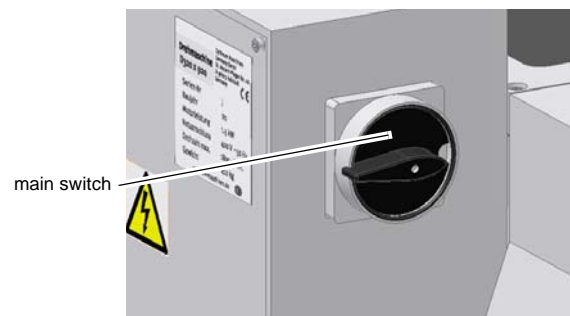

Illustr. 1-1: main switch



**WARNING!**

**Dangerous voltage even when the main switch is switched off.**

In the areas marked by the ideogram in the margin, there might be voltage, even if the main switch is switched off.

### 1.7.2 EMERGENCY-STOP

The EMERGENCY-STOP turns the lathe off.

Pushing the emergency stop device triggers an emergency stop.

After actuating the switch, turn it to the right, in order to rest it.

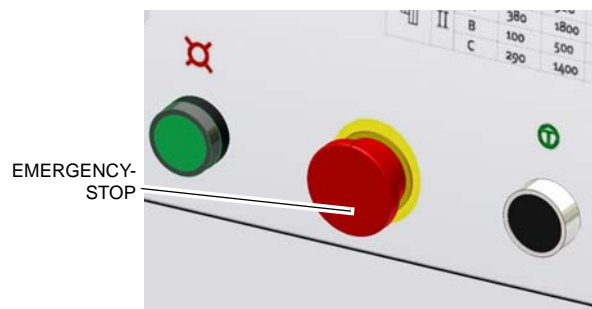

Illustr. 1-2: EMERGENCY-STOP

## 1.7.3 Lathe chuck protection with position switch

The lathe is provided with chuck guard. The lathe can only be turned on when the chuck guard is closed.

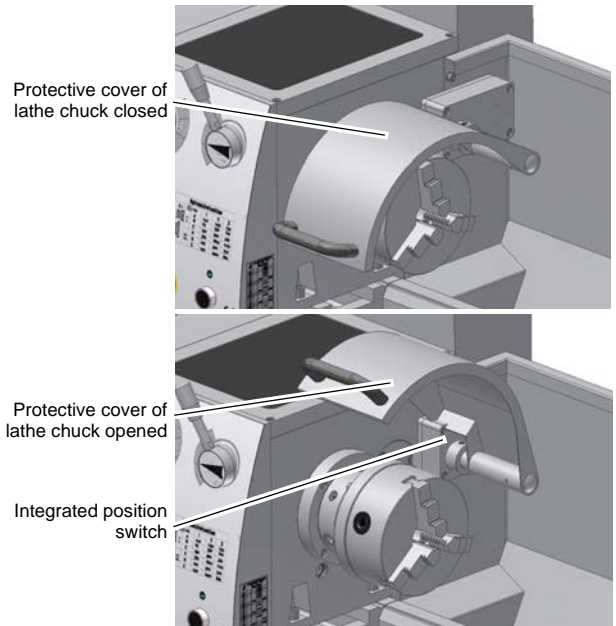

Illustr. 1-3: lathe chuck protection

## 1.7.4 Protective cover with safety switch

The spindle head of the lathe is equipped with a fixed, separating protective cover. The locked position is monitored by means of an electrical limit switch.

### INFORMATION



It is not possible to start the machine until the protective cover is closed.

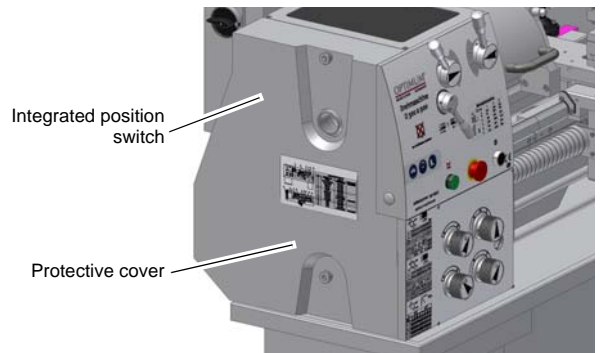

Illustr. 1-4: Protective cover of spindle head

## 1.7.5 Protective cover feed shaft, feed shaft clutch

The lathe is provided with a protective cover (coil spring) for longitudinal lead screw.

A clutch is mounted on the feed shaft.

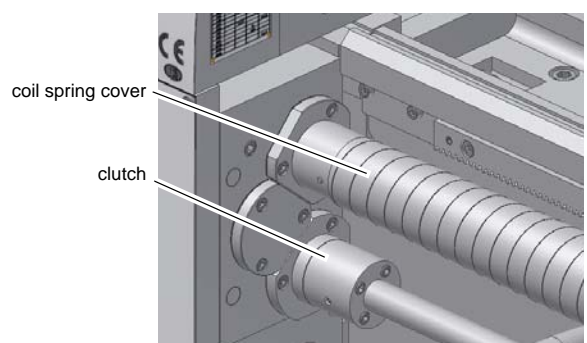

Illustr. 1-5: protective cover feed shaft

1.7.6 Prohibition, warning and mandatory labels



**INFORMATION**

All warning labels must be legible. Check them regularly.

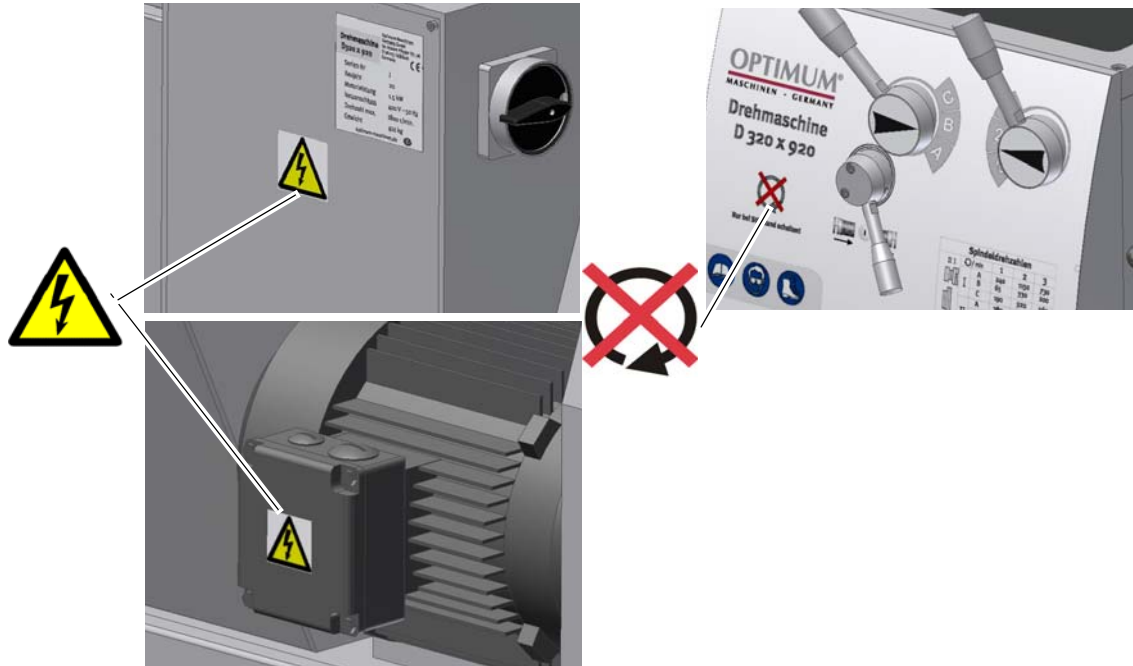

Illustr. 1-6: warning labels

1.8 Safety check

Check the lathe at least once per shift. Inform the person responsible immediately of any damage, defect or change in operating function.

Check all safety devices

- at the beginning of each shift (with the machine stopped),
- once a week (with the machine in operation),
- after every maintenance and repair work.

Check that prohibition, warning and information labels as well as the markings on the lathe are

- legible (clean them, if necessary),
- complete.



**INFORMATION**

Use the following table in order to organize the checks.

General check		
equipment	check	OK
protective covers	mounted, firmly bolted and not damaged	
labels, markings	installed and legible	
<b>Date:</b>	<b>checked by (signature):</b>	

Functional check		
equipment	check	OK
EMERGENCY-STOP	When the EMERGENCY-STOP switch is activated, the lathe should switch-off automatically.	
Position switch of the lathe chuck guard.	The lathe shall only turn on after closing the lathe chuck guard.	
Position switch for the protective cover of the headstock	The lathe shall only turn on if the protective cover is mounted to the headstock.	
<b>Date:</b>	<b>checked by (signature):</b>	

## 1.9 Personal protective equipment

For certain work personal protective equipment is required.



Protect your face and your eyes: Wear a safety helmet with a face guard for all work, especially for work where your face and eyes are exposed to hazards.



Use protective gloves when lifting or handling pieces with sharp edges.



Wear safety shoes when fitting, dismanteling or transporting heavy components.



Use ear protection if the noise level (immission) in the workplace exceeds 80 dB (A).

Before starting work, make sure that the prescribed personal protective equipment is available at the workplace.



### CAUTION!

**Dirty or eventually contaminated personal protective equipment might cause disease. Clean it after every use and once a week.**

## 1.10 Safety during operation

In the description of work with and on the lathe we highlight the dangers specific to that work.



### WARNING!

**Before activating the lathe, double check that this will not endanger other people or cause damage to equipment.**

Avoid unsafe working practice:

- Make sure, your work does not endanger anyone.
- Clamp the workpiece tightly before activating the lathe.
- Observe the maximum chuck opening.
- Use safety glasses.
- Do not remove turning chips by hand. Use a chip hook and / or a handbrush to remove turning chips.
- Clamp the turning tool at the correct height and with the least possible overhang.

- Turn off the lathe before measuring the workpiece.
- The instructions of this manual must be observed strictly during assembly, operation, maintenance and repair.
- Do not work on the lathe, if your concentration is reduced, for example, because you are taking medication.
- Observe the regulations for the prevention of accidents issued by your association for the prevention of occupational accidents and safety in the workplace or other inspection authorities.
- Inform the inspector of any danger or failure.
- Stay by the lathe until all rotating parts have come to halt.
- Use the prescribed personal protective equipment. Make sure to wear a well-fitting work suit and a hairnet, if necessary.

## 1.11 Safety during maintenance

Inform the operating staff in good time of any repair and maintenance work.

Report all safety-relevant changes or performance details of the lathe. Document all changes, have the operating manual changed accordingly and train the machine operators.

### 1.11.1 Switching off and securing the lathe



Disconnect the lathe from power before beginning any maintenance or repair work.

Secure the main switch by a lock against unauthorized switching on and keep the key in a safe place.

All machine components and hazardous voltages are disconnected.



Except the areas marked by the ideogram in the margin. In these areas there might be voltage even if the main switch is disconnected.

Attach a warning sign on the lathe.



#### **WARNING!**

**Live components and movement of machine parts may cause severe injury to you or other persons!**

**If the work requires (e.g. in case of a functional control) not to pull the main plug of the lathe, proceed with extreme care.**

### 1.11.2 Use of lifting equipment



#### **WARNING!**

**Use of unstable lifting and load-suspension gear that might break under load can cause very serious injuries or even death.**

**Check that the lifting and load suspension gear is of sufficient load capacity and in perfect condition.**

**Observe the regulations for the prevention of accidents issued by your association for the prevention of occupational accidents and safety in the workplace or other inspection authorities.**

**Fasten the loads properly.**

**Do not walk under lifted loads!**

### 1.11.3 Mechanical maintenance work

Remove protection and safety devices as required before starting maintenance work and re-install them once the work has been completed, such as:

- covers,
- safety indications and warning signs,
- earth (ground) connections.

If you remove protection or safety devices, refit them immediately after completing the work.

Check if they are working properly!

### 1.12 Accident report

Inform your superiors immediately in case of accidents, possible sources of danger and any actions which almost led to an accident ("near misses").

"Near misses" may have many possible causes.

The sooner they are notified, the faster these causes can be eliminated.



#### INFORMATION

In the description of execution of work with and on the lathe we highlight the dangers specific to that work.

### 1.13 Electrical system

Have the machine and / or the electrical equipment checked regularly, but at least every six months. Eliminate immediately all defects such as loose connections, defective wires, etc.

A second person must be present during work on live components, to disconnect the power in case of an emergency. Disconnect the lathe immediately if there is a malfunction in the power supply!

☞ „Maintenance“ on page 57



## 2 Technical Data

The following data give dimensions and weight and are the manufacturer's authorized machine data.

<b>2.1 Power connection</b>	D320 x 920	D320 x 920 DPA
connection	115/230V, 1,5 kW, 1 Ph, 60 Hz	

<b>2.2 Machine data</b>	D320 x 920	D320 x 920 (DPA)
Height of centers	156mm (6.14")	
Distance between centers	910mm (35.83")	
Swing over bed	312mm (12.28")	
Swing over support	190 (7.48")	
Swing bed insert removed	430 (16.93")	
Length of bed insert	230 (9.05")	
Bed width	187 (7.36")	
Bed length	1180 (46.46")	
Bed height	295 (16.61")	
Spindle speed [rpm]	65; 100; 190; 200; 240; 290; 320; 330; 380; 500; 560; 730; 860; 920; 1100; 1150; 1400; 1800	
Spindle taper	MT 5	
Spindle seat	Camlock ASA D 1 - 4"	
Spindle thru hole	38 (1.50")	
Longitudinal feed range	0.002-0.055" (32 pcs longitudinal feeds)	
Longitudinal Lead Screw size	7/8"-8 TPI	
Longitudinal Feed Dial graduation	0.006" (1rev = 9/16")	
Thread Cutting Pitches - Inches [tpi]	56 - 4 34 pitches	
Thread Cutting Pitches - Metric [mm]	0.4 - 7 26 pitches	
Operating travel cross slide	162 (6.38")	
Crossfeed range	0.0007 - 0.019" (32 crossfeeds)	
Cross feed Lead Screw size	5/8"-10 TPI	
Cross feed Dial graduation	0.002" (1rev = 0.2") indirect	
Operating travel compound slide	85 (3.35")	
Adjustment range of the compound slide	+ - 90°	
Compound feed Lead Screw size	9/16"-10 TPI	
Compound feed Dial graduation	0.001" (1rev = 0.1")	
Taper bore of tailstock sleeve	MT 3	
Tailstock sleeve travel	100 (4")	
Tailstock cross adjustment	+ - 10 mm (0.39")	
Tailstock feed Lead Screw size	9/16"-10 TPI	
Tailstock feed Dial graduation	0.001" (1rev = 0.1")	
Maximum dimensions of the turning tool shank to fit in quadruple tool holder	16 x 16mm (5/8" x 5/8")	
Quadruple tool holder surface to the turning center distance	10.8mm (0.42")	

<b>2.2 Machine data</b>	D320 x 920	D320 x 920 (DPA)
Maximum permissible rpm for jaw chucks	3 - jaw chuck	4 - jaw chuck
160mm (6.30")	2300 (rpm)	2000 (rpm)
200mm (7.87")	1800 (rpm)	1500 (rpm)

The indicated values of the maximum permissible number of revolutions (rpm) apply to the original chucks that were supplied with the lathe and when jaws do not stick out over the outside edge, jaws are tightly clamped on the workpiece which does not exceed a specific imbalance of 25 gmm/kg.

When using different chuck, always use maximum permissible number of revolutions as indicated by chuck manufacturer. This number of revolutions can be different than the number of revolutions indicated above and must be used.

### WARNING!

**When assembling and using of the lathe with a frequency converter the maximum permissible number of revolutions for the jaw chuck can be exceeded. We are not responsible for damage and/or damages during disregard.**

<b>2.3 Dimensions</b>	D320 x 920	D320 x 920 DPA
Height	51.97"	
Length	66.33"	
Depth	29.52"	
Total weight (lbs)	1157	
Foor loading	9 KN / m <sup>2</sup> [1.3 psi]	

<b>2.4 Work area</b>	D320 x 920	D320 x 920 DPA
Height	78.74"	
Length	133.85"	
Depth	94.49"	

<b>2.5 Environmental conditions</b>	D320 x 920	D320 x 920 DPA
Temperature	40 - 95 °F	
Humidity	25 - 80 %	

<b>2.6 Operating material</b>	D320 x 920	D320 x 920 DPA
Headstock	Mobilgear 627 or other equivalent oil	
	filling quantity 3.2 litres [3.4 qt]	
Gears of apron	Mobilgear 629 or other equivalent oil	
	filling quantity 0.5 litres [ 0.5 qt]	
Feed gear	Mobilgear 629 or other equivalent oil	
	filling quantity 0.9 litres [0.95 qt]	
Bright steel parts and lubrication nipple	Machine oil (e.g. Mobile oil, Fina oil, ...). We recommend the use of machine oil, that is free from acid, stains and resin.	

## 2.7 Emissions

The level of noise emitted by the lathe is 79 dB(A) at no-load operation.



### INFORMATION

This numeric value had been measured on a new machine under conventional operating conditions. Depending on the age or wear of the machine, the noise behavior of the machine might change.

Furthermore, the extent of the noise emission is also depending on manufacturing influence factors, such as speed, material and clamping conditions.



### INFORMATION

The mentioned numerical value is an emission level and not necessarily a safe working level.

Unless the degree of noise emission and the degree of noise disturbance are depending on one another it is not possible to use it in order to reliably determine if it is necessary to take further preventive measures or not.

The following factors influence the actual degree of the noise disturbance of the operator:

- Characteristics of the working chamber, e.g. size or damping behavior,
- Other noise sources, e.g. the number of machines,
- Other processes proceeding nearby and the period during which the operator is exposed to the noise.

Furthermore, the admissible pollution level may be different from one country to another due to the national regulations.

This information regarding the noise emission should allow the operator of the machine to perform a better evaluation of the endangerments and risks.



### CAUTION!

**The machine operator has to wear an appropriate ear protection depending on the overall stress caused by noise and on the basic limit values.**



**We generally recommend using a sound and ear protection.**

## 2.8 Dimensions, installation plan D320x920



Abb.2-1: Dimensions, installations plan D320x920

## 2.9 Dimensions, installation plan D320x920 DPA

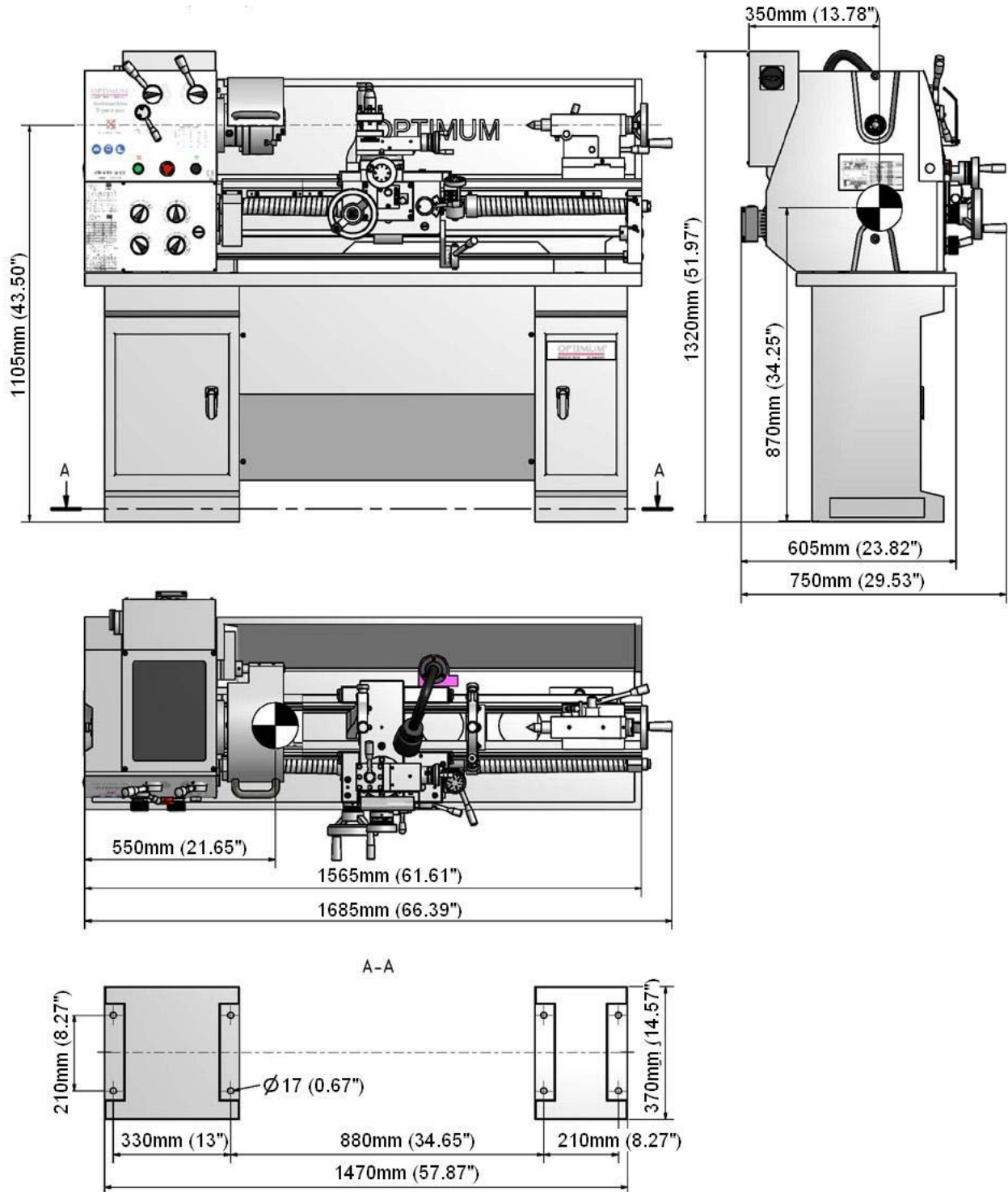

Abb.2-2: Dimensions, installations plan D320x920 DPA

## 3 Assembly

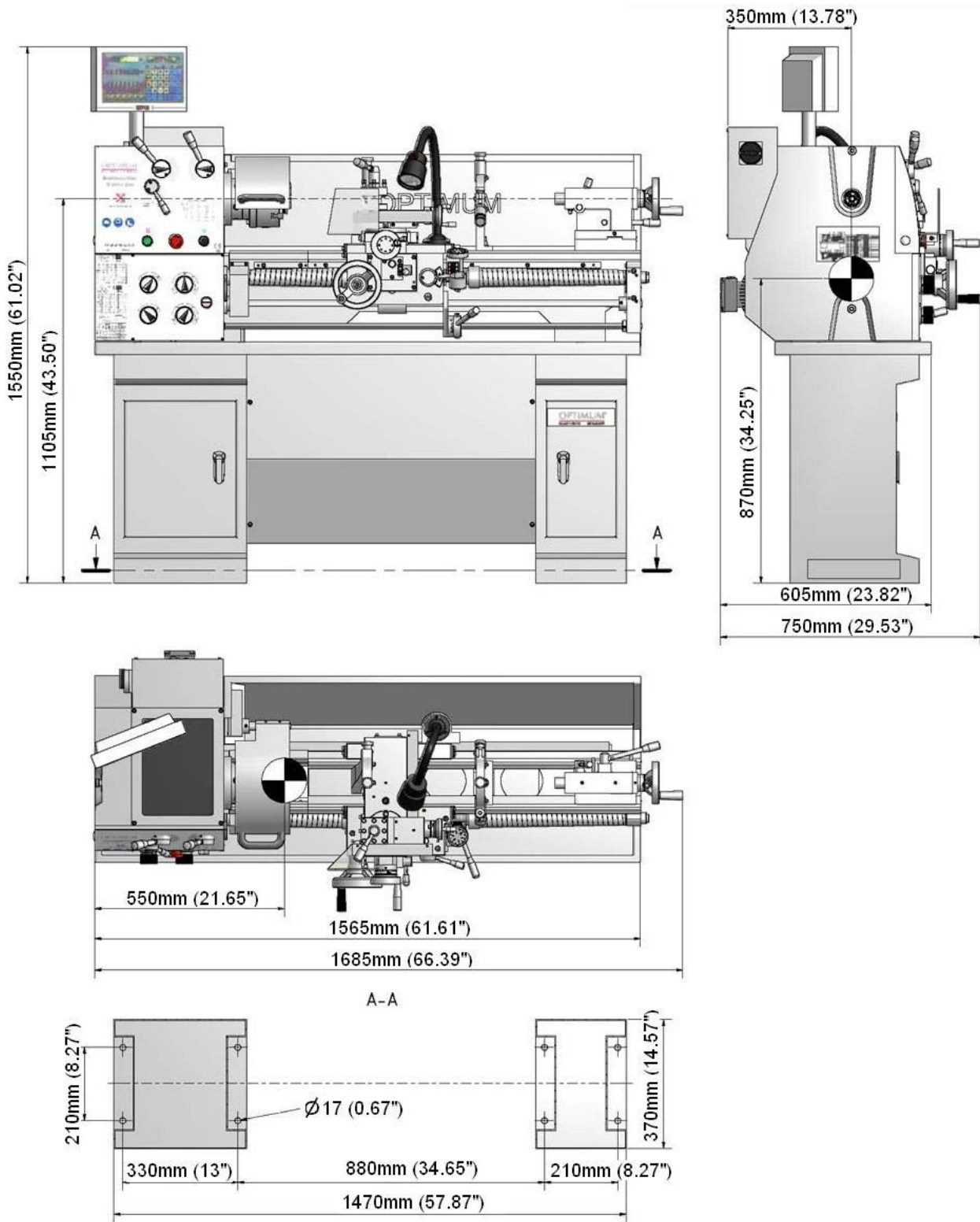

### INFORMATION

The lathe is being delivered pre-assembled.

### 3.1 Delivery volume

When the lathe is delivered, please check immediately that it has not been damaged during transportation and that all components are included.

Compare the delivery volume to the indications on the packing list.



### WARNING!

**Risk by using improper workpiece clamping materials or by operating the machine with inadmissible speed.**

**Only use the clamping materials (e.g. lathe chuck) which had been delivered together with the machine or as optional equipment offered by OPTIMUM.**

**Use the working clamping materials only in the provided admissible speed range.**

**Workpiece clamping materials must only be modified according to the recommendations of OPTIMUM or of the clamping material manufacturer.**

### 3.2 Optional lathe accessories

Description	item number
Röhm three jaw chuck 200 mm	344 1531
Röhm four jaw chuck 200 mm	344 1532
Röhm face plate chuck 260 mm, direct holding fixture Camlock D 1- 4 "	344 1538
universal collet chucking attachment 5C	344 1506
draw-in collet chuck Camlock D 1- 4 " 5C	344 1504
set of collet chucks 3 - 25 mm, 17 pcs 5C	344 1509
quick change tool holder SWH 3-E	338 4303
universal coolant appliance 230V	335 2002

### 3.3 Transport

- Center of gravity
- Attachment positions (marking the positions for the attachment position gear)
- Prescribed transport position (marking the top side)
- Means of transportation to be used
- Weights

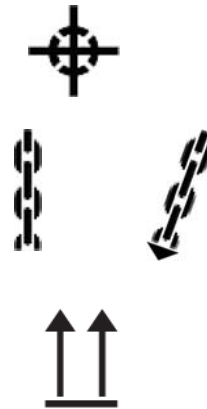

**WARNING!**

Machine parts which fall off forklift trucks or other transport vehicles could cause very serious or even fatal injuries. Follow the instructions and information on the box.



**WARNING!**

Use of unstable lifting and load suspension gear that breaks under load can cause very serious injuries or even death.

Check that the lifting and load suspension gear has sufficient load capacity and is in perfect condition. Observe the rules for preventing accidents issued by your association for the prevention of occupational accidents and safety in the workplace or other inspection authorities.

Hold the loads properly. Never walk under suspended loads!

## 3.4 Storage



### ATTENTION!

Improper storage may cause important parts to be damaged or destroyed. Store packed or unpacked parts only under the following ambient conditions. Please follow the instructions and indications on the transportation box.

- Fragile goods (goods require careful handling)



- Protect against humidity and humid environments  
 „Environmental conditions“ on page 18.



- Prescribed position of the packaging box (marking the top side – arrows pointing upward)



- Maximum stacking height

Example: non-stackable – do not pile any further packaging boxes on top of the first packaging box



## 3.5 Installation and assembly

### 3.5.1 Requirements of the installation site



### ATTENTION!

Before installing the machine, have the load bearing capacity of the subsoil checked by a specialist. The floor and the ceiling of the hall have to bear the weight of the machine plus all additional parts and additional aggregates as well as the operator and the stocked materials. Reinforce the subsoil, if necessary.



### INFORMATION

In order to provide for good functionality and high machining accuracy as well as long durability of the machine the site should fulfill certain criteria.

#### Observe the following items:

- The device must only be installed and operated in dry ventilated places.
- Avoid places nearby machines generating chips or dust.



- The site has to be vibration-free, i.e. at a distance from presses, planing machines, etc.
- The substructure has to be appropriate for turning. Also make sure that the load bearing capacity and the evenness of the floor are appropriate.
- The substructure has to be prepared in a way that possibly used coolant cannot penetrate into the ground.
- Protruding parts such as stops, handles, etc. need to be secured by measures provided by the customer if necessary in order to avoid dangers for persons.
- Provide sufficient space for assembly and operating staff as well as for material transport.
- Also allow for accessibility for setting and maintenance works.
- Make sure that the mains plug of the turning machine is freely accessible.
- Provide for sufficient illumination (minimum value: 300 lux, measured at the tool tip). In case of little intensity of illumination provide for additional illumination i.e. by a separate workplace illuminator.



**INFORMATION**

The mains plug of the lathe has to be freely accessible.

**3.6**

**Load end position**

- Fasten the load end material around the lathe bed.
- Make sure to get an equal load end position and that the lathe does not overturn when it is being lifted.
- Make sure that no components are being damaged or that there are no defects in the paint work due to the load end.

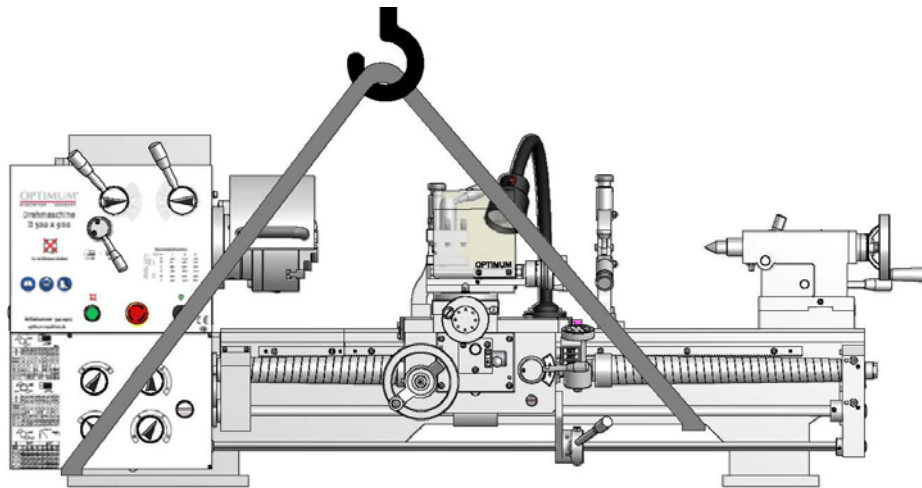

Illustr. 3-1: load end position

### 3.6.1 Installation



#### WARNING!

**Danger of crushing and overturning. The installation of the lathe must be performed by at least two persons.**

→ Check the foundation of the lathe with a water spirit on horizontal alignment.

→ Check the foundation on sufficient soil bearing capacity and rigidity.



#### ATTENTION!

**Insufficient rigidity of the foundation leads to the superposition of vibrations between the lathe and the foundation (natural frequency of components). Insufficient rigidity of the entire lathe assembly also rapidly causes the lathe to reach critical speeds, with unpleasant vibrations, leading to bad turning results.**

→ Assemble the stand.

→ Fasten the stand to the floor.

→ Put the lathe on the stand.

→ Fasten the lathe to the stand by using the provided hex head bolts (8 pieces).

☞ „Dimensions, installation plan D320x920 DPA“ on page 21

### 3.6.2 Anchoring-free assembly

→ If necessary, use machine leveling mounts (not supplied).

→ Adjust the lathe by means of precision level for machines.

- Check the adjustment once again after a few days of operation.

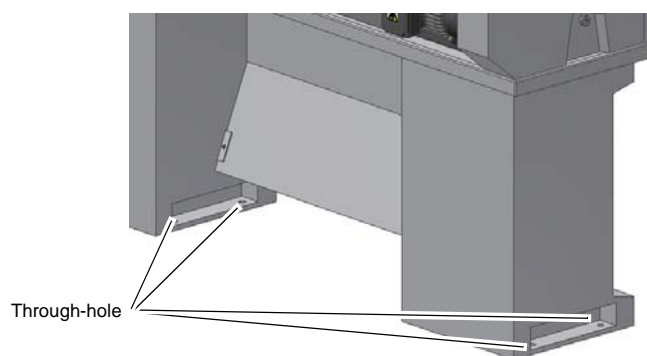
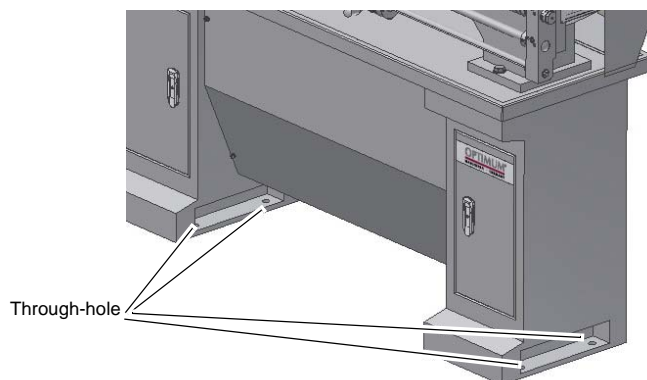

Illustr. 3-2: Installation

### 3.6.3 Anchored assembly

Use the anchored assembly in order to realize a stiff attachment to the foundation. The anchored assembly is always useful if it is intended to treat large parts up to the maximum capacity of the lathe.

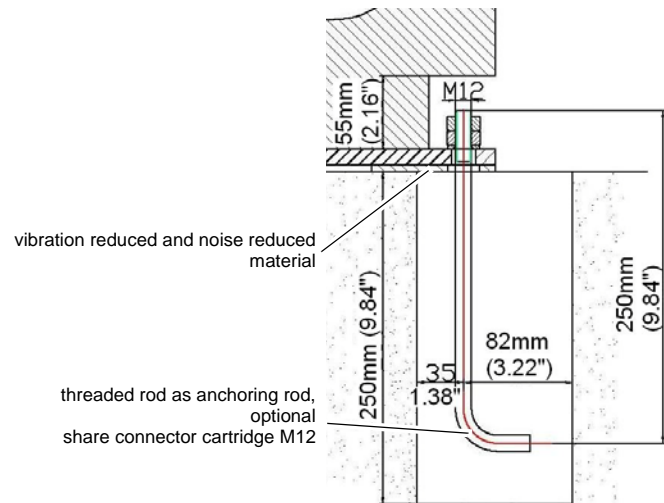

Illustr. 3-3: drawing anchoring

### 3.7 First use



#### WARNING!

Personnel and equipment may be endangered if the lathe is first used by an untrained employee. We do not take any liability for damages caused by incorrect commissioning.

#### 3.7.1 Cleaning and greasing

- Remove the anti-corrosive agent applied to the lathe for transport and storage purposes. We recommend the use of WD-40 oil.
- Do not use any solvents, thinner or other cleaning agents which could corrode the varnish on the lathe. Follow the specifications and indications of the manufacturer of the cleaning agent.
- Lubricate all bright machine parts with acid-free lubricating oil.
- Grease the lathe according to the lubrication chart. ☞ „Inspection and maintenance“ on page 59

#### 3.7.2 Visual inspection

Check the oil level in the inspection glass of the spindle head, of the feed gear and of the apron. ☞ „oil-sight glasses“ on page 62, filling quantity ☞ „Operating material“ on page 18

#### 3.7.3 Functional check

- Check free movement of all spindles.

#### 3.7.4 Power connection

#### WARNING!



All electrical connections must be performed by a qualified electrician. Make sure tool is off and disconnected from power source while motor is mounted, connected, reconnected or any time wiring is inspected.

- The lathe and the motor come prewired for 230 volts operation.

→ Power cord must be hard wired or adequate, 3-prong plug and receptacle must be used.

→ Recommended Dayton plugs, connectors and receptacles for 115 volts:

30 Amps Plug	125 Volts Connector	NEMA L5-30 Receptacle
--------------	---------------------	-----------------------

4A262      4A263      4A261

→ Recommended Dayton plugs, connectors and receptacles for 230 volts:

20 Amps Plug	250 Volts Connector	NEMA L6-20 Receptacle
--------------	---------------------	-----------------------

5A081      5A082      5A080

30 Amps Plug	250 Volts Connector	NEMA L6-30 Receptacle
--------------	---------------------	-----------------------

5A087      5A088      5A086

→ A label on the motor describes the possible wiring configurations. There are many different possible combinations, so only the diagram provided with the motor should be used.

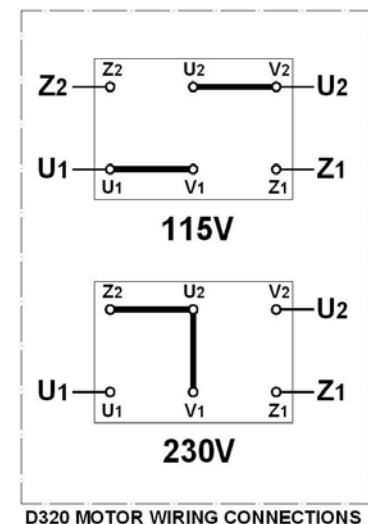
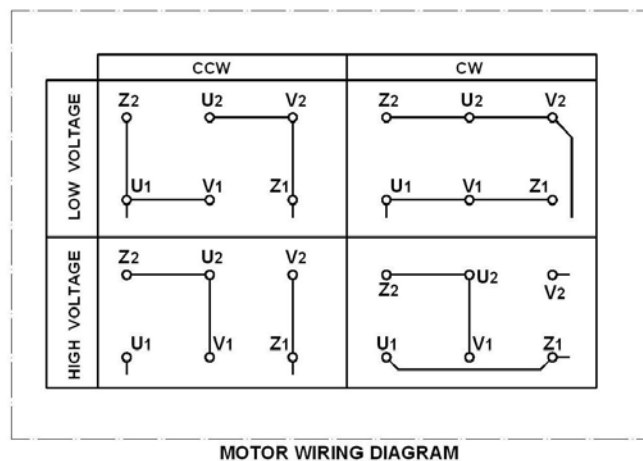

Illustr. 3-4: Motor wiring

→ The motor cord must be secured to protect the wiring connections from possible strain.

→ The power supply to motor is controlled by a reversing circuitry inside lathe's control box. Power lines are connected to the quick connect terminals of the control box.

→ The green ground line must remain securely fastened to the motor ground terminal to provide proper grounding.

→ To operate lathe at **230 volts**:

- Replace line cord plug with a 230 volt, 20A, 3-prong plug.
- Rewire motor as shown in (☞ Illustr. 3-4: „Motor wiring“ on page 28) under D320 MOTOR WIRING CONNECTIONS. If motor label has a different wiring configuration, use the motor label diagram to rewire motor.
- D320 MOTOR WIRING CONNECTIONS as shown in (☞ Illustr. 3-4: „Motor wiring“ on page 28) corresponds to motor wiring diagram as shown at the left. Reversing circuitry connections are made inside lathe's control box and are not shown in the wiring connections at the right.

- Please note that lead wire Z2 is not used for 230V connection and must be disconnected from terminal block inside the control box and removed from the bundle. Optionally, this wire can be left in the bundle for future use but both of its ends must be very well insulated with electrical tape.

For 230 volts operation  
disconnect Z2 wire  
and remove from the bundle

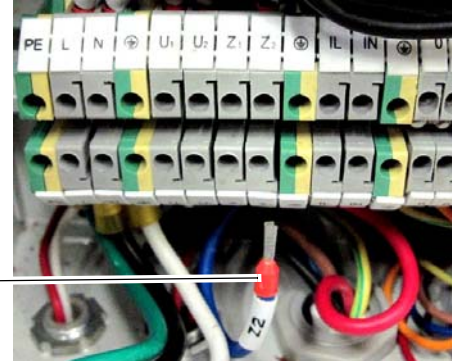

Illustr. 3-5: 230 volts wiring

- Rewire transformer to 230V by switching N wire from terminal # 21 to terminal # 22 as shown in (Illustr. 3-6: „Transformer wiring“ on page 29).

115 volts connection

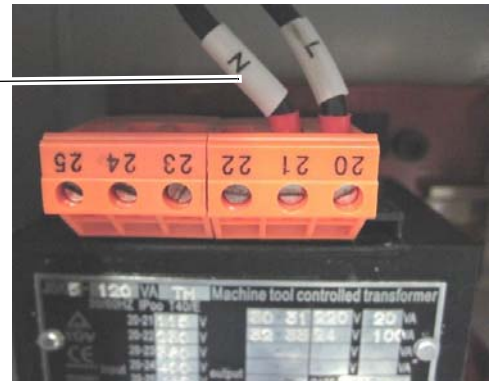

230 volts connection



Illustr. 3-6: Transformer wiring

- Set thermal overload to 17A.

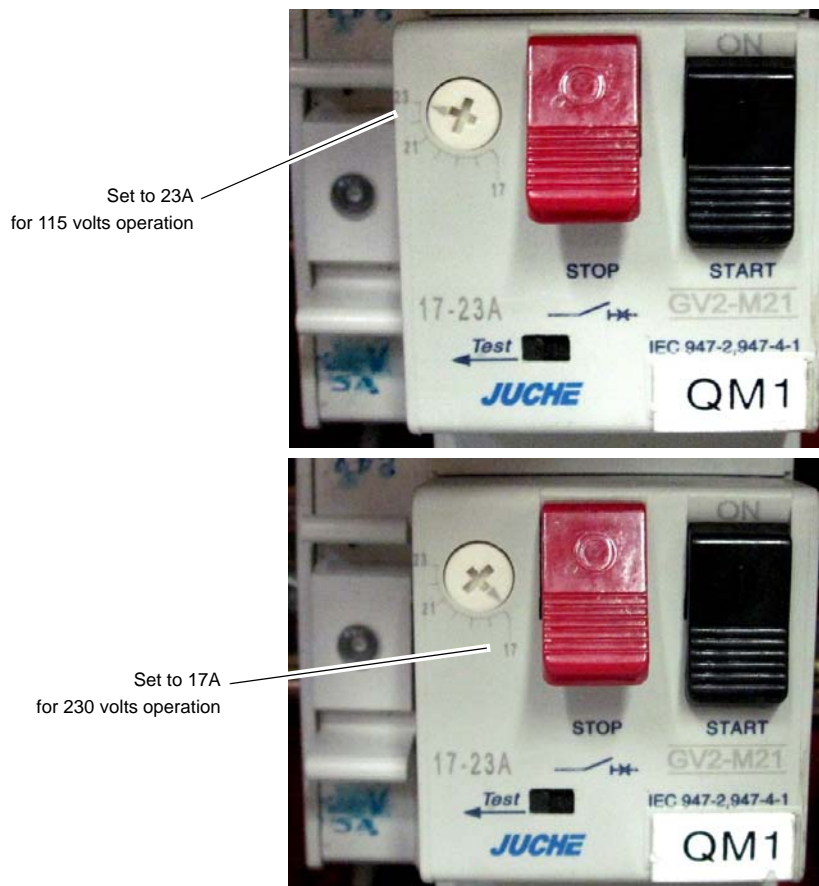

Illustr. 3-7: Thermal overload setting



### INFORMATION

Please note that while your lathe could be wired and used with 115V, it will perform the best when wired to 230V operation.

### 3.7.5

#### Functional test

- Carry out a safety test. ☞ „Safety check“ on page 13
- Check the turning direction of the lathe. The main spindle must turn anti-clockwise with the control lever at the apron turned down. Rewire the motor, if the turning direction is wrong.



### INFORMATION

For a long service life of your lathe, we recommend you not to exceed

- a maximum speed of 730 (rpm) during the first three operating hours,
- a maximum speed of (rpm) for another two operating hours,
- a maximum speed of (rpm) after another operating hour.

## 4 Operation

### 4.1 Safety

Operate the lathe only under the following conditions:

- The lathe is in proper working condition.
- The lathe is used as prescribed.
- The operating manual is being followed.
- All safety devices are installed and activated.



Any malfunctions should be eliminated immediately. Stop the lathe immediately in the event of any malfunctioning in operation. Make sure it cannot be started up accidentally.

Notify the person responsible immediately of any malfunction.

☞ „Safety during operation“ on page 14

### 4.2 Control and indicating elements

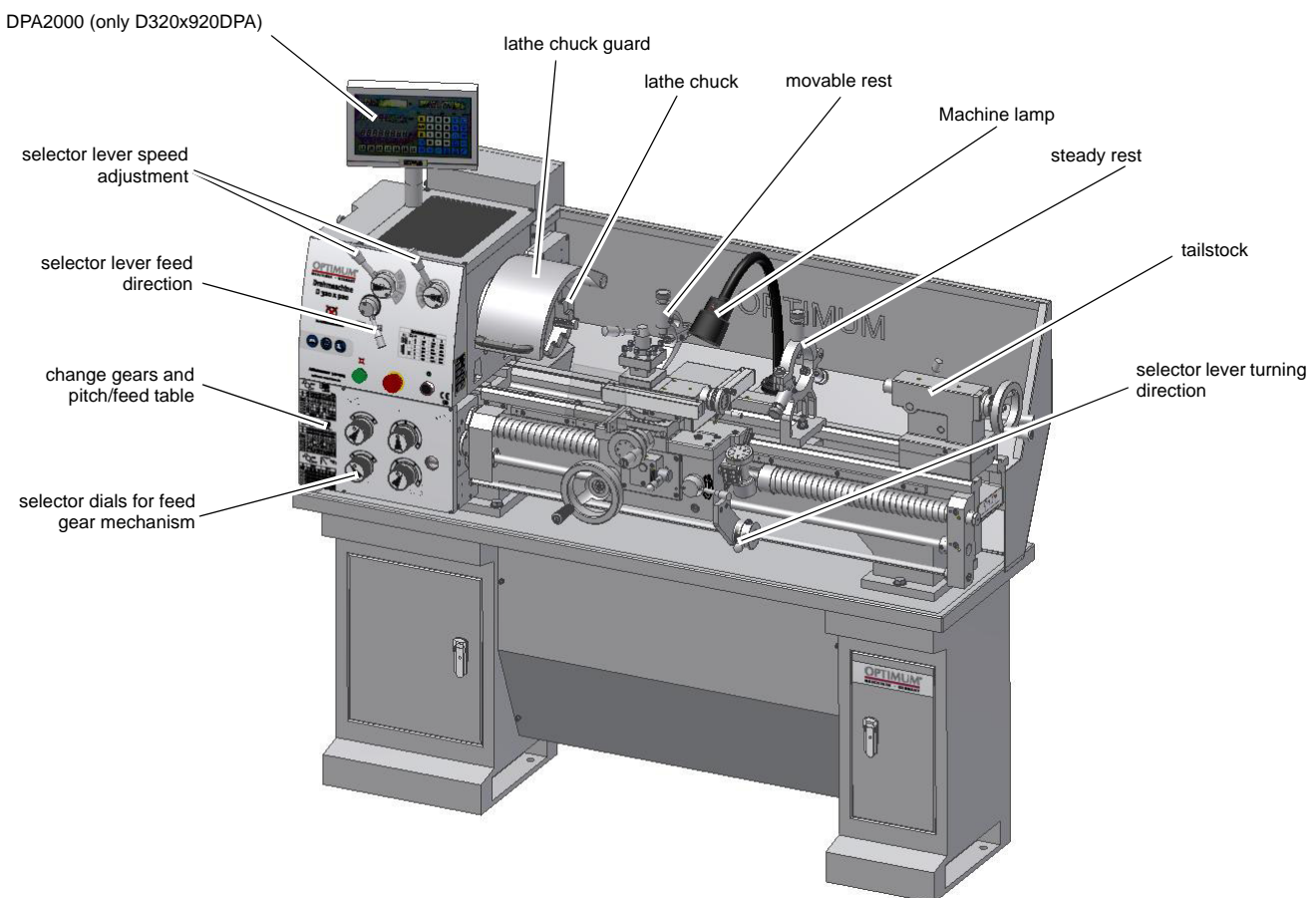

Illustr. 4-1: D320x920 DPA

## 4.2.1 Overview of control elements

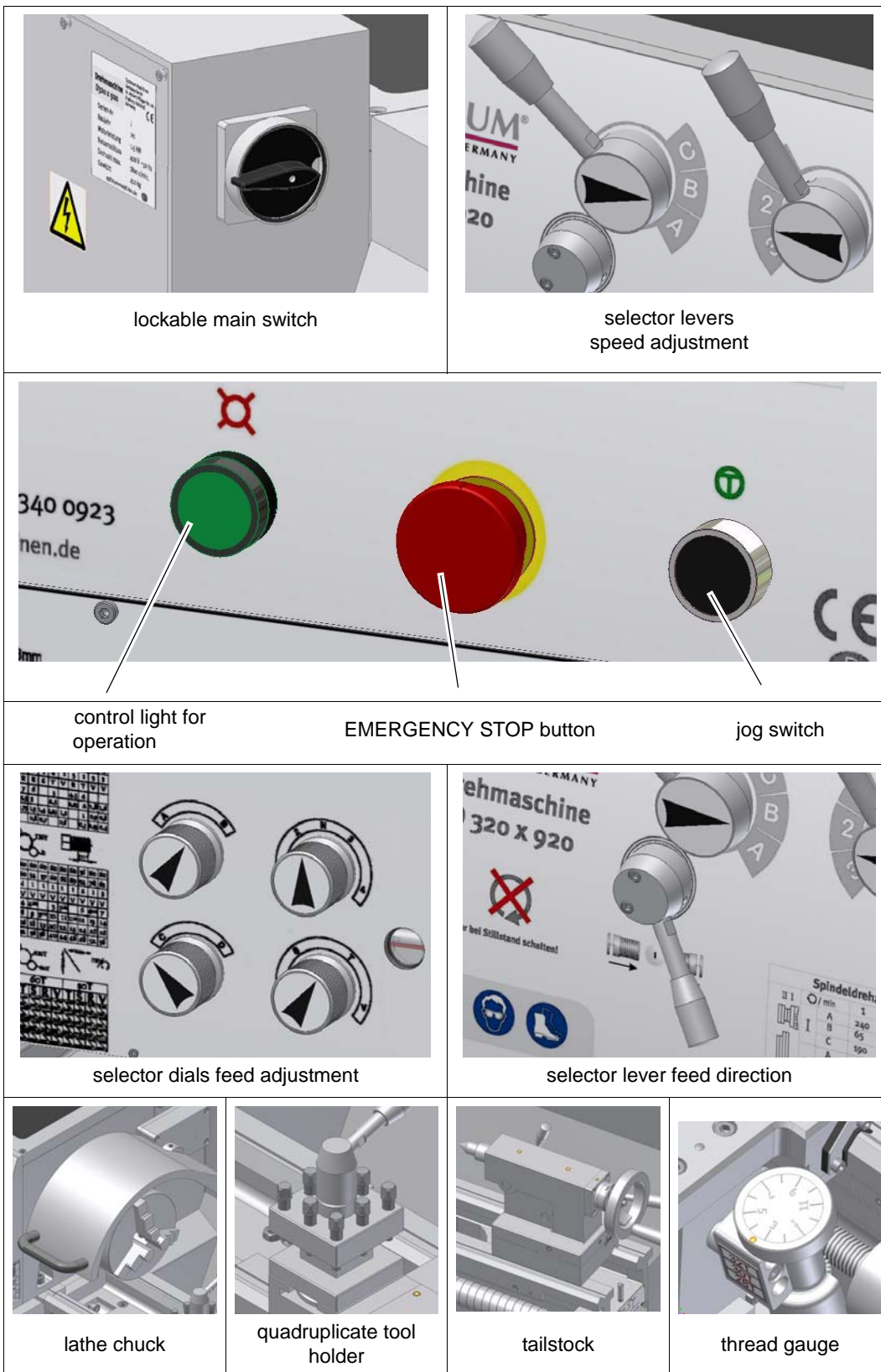





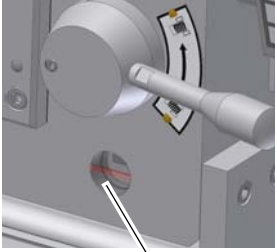
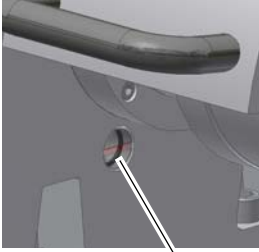
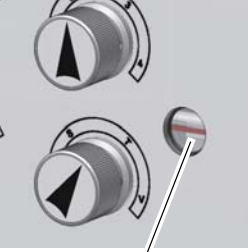
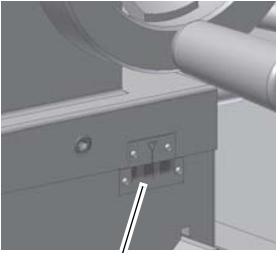
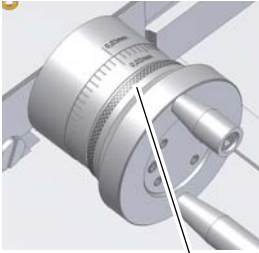
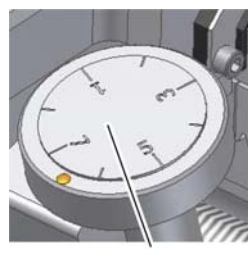

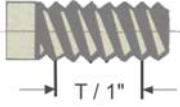
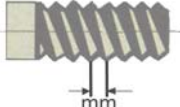

4.2.2 Overview of indicating elements

 <p>oil sight glass apron</p>	 <p>oil sight glass headstock</p>	 <p>oil sight glass feedgear mechanism</p>
 <p>scale tailstock offset</p>	 <p>scale on the handwheels</p>	 <p>scale thread gauge</p>

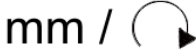
4.2.3 Control elements

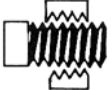
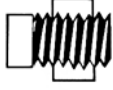
 <p>longitudinal feed</p>	 <p>crossfeed</p>
 <p>inch thread [ threads / inch ]</p>	 <p>metric thread [ mm / spindle revolution ]</p>
 <p>modular thread / diametrical thread</p>	 <p>mm /  mm per revolution</p>
 <p>lead screw-nut disengaged</p>	 <p>lead screw-nut engaged</p>

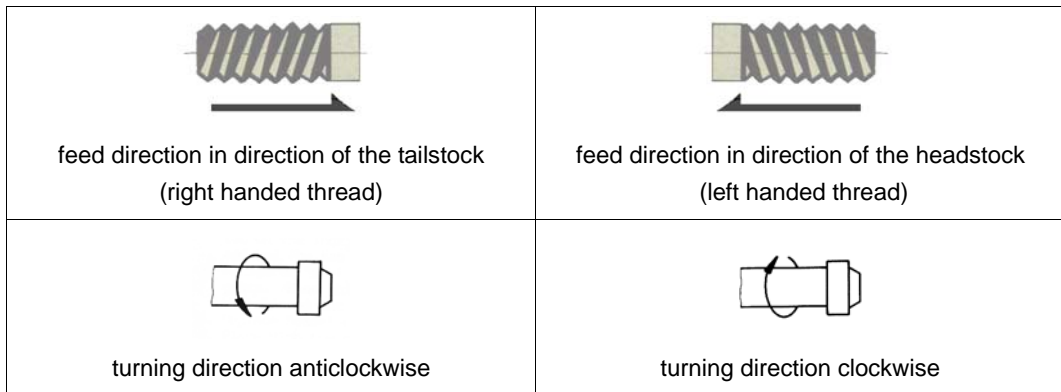

## 4.3 Speed adjustment



### ATTENTION!

Only change the speed when the lathe is completely stopped.

There are 18 speeds at disposal.

The speed is adjusted with the two selection levers A / B / C and 1 / 2 / 3. In dependence on the V-belt position, you will get the speed according to the following table.

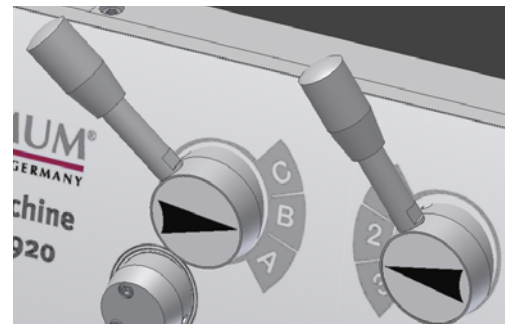

Illustr. 4-2: speed adjustment

### 4.3.1 Speed table D 320 x 920

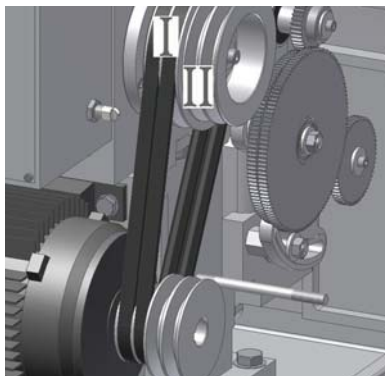

		⤵ / min	1	2	3
II I	I	A	240	1150	730
		B	65	330	200
		C	190	920	560
II	II	A	380	1800	1100
		B	100	500	320
		C	290	1400	860

Illustr. 4-3: speed table D 320 x 920



Use the jog button to index machine's control levers into position.

### 4.3.2 Position change of the V-belt positions



### WARNING!

Disconnect the lathe from power supply and secure the main switch with a lock.



- Dismount the protective cover of the change gear.
- Loosen motor mounting bolts.
- Release the V-belts by pushing the motor up.
- Put the V-belts on the other V-belt pulleys.
- Retighten the V-belts by pushing the motor down.
- Retighten motor mounting bolts.

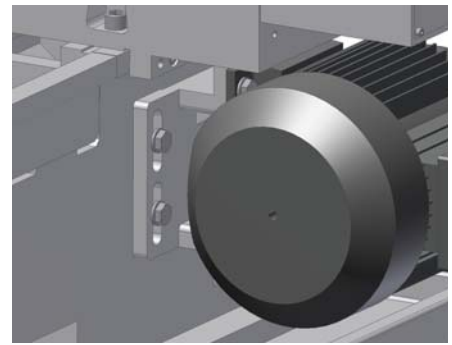

Illustr. 4-4: motor mounting bolts



**ATTENTION!**

**Make sure the V-belts have the right tension.**



**INFORMATION**

The V-belts are having the right tension if you can press into each one of them about 5mm (3/16") with your finger.

**4.3.3**

**Turning direction**

The lathe is switched on by the control lever. The lathe only runs with the lathe chuck guard closed.

- Turn the control lever down if you want the turning direction to be anti-clockwise.
- Turn the control lever up if you want the turning direction to be clockwise.

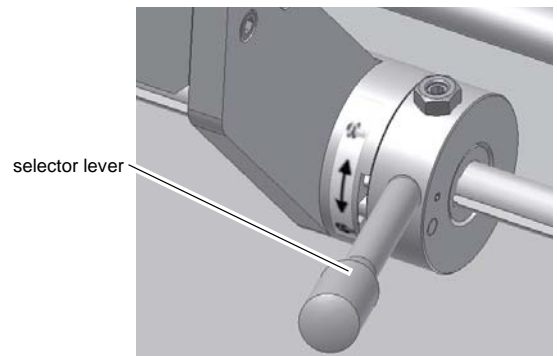

Illustr. 4-5: selector lever turning direction



**ATTENTION!**

**Wait until the lathe has come to a complete halt before changing the turning direction using the control levers.**

**Changing the turning direction during operation may cause damage to components.**

**4.4**

**Feed**

The selector levers (dials) are used to change the infeed or the required pitch for thread cutting.



**ATTENTION!**

**Only change the dials position in complete standstill of the machine.**

**If necessary, use the jog button to facilitate the coming of the switch.**

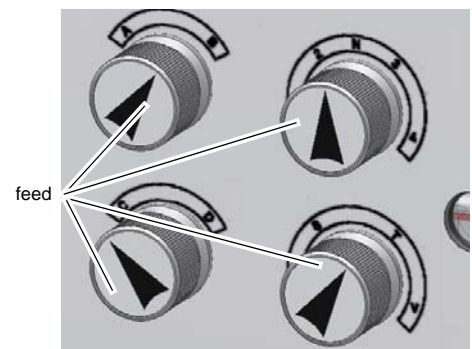

Illustr. 4-6: selector lever feed

### 4.4.1 Rate of feed

There are rates of feed in the range from 0.002" to 0.055" for longitudinal feed (32 longitudinal feeds) and 0.0007" to 0.019" for cross feed (32 cross feeds) per spindle rotation. Use the table on the lathe to adjust the rate of feed.

### 4.4.2 Feed direction

The feed direction is changed with the selector lever.

- Turn the selector lever to the left or right according to the symbols for longitudinal feed or for the production of right or left handed threads.

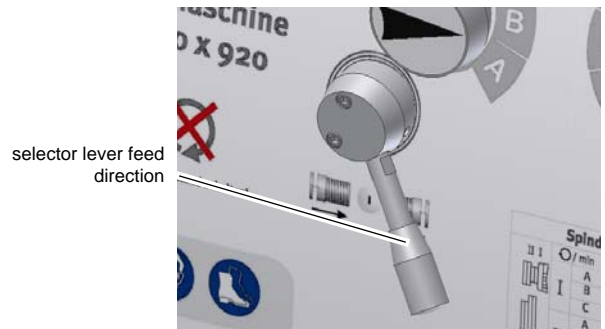

Illustr. 4-7: selector lever feed direction

### 4.5 Tool holder

Clamp the turning tool into the toolholder.

The tool must be clamped firmly and with the least possible overhang in order to absorb well and reliably the cutting force generated during the chip formation.

- ☞ „Maximum dimensions of the turning tool shank to fit in quadruple tool holder“ on page 17

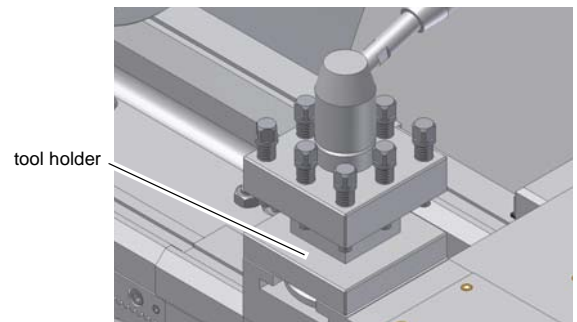

Illustr. 4-8: tool holder

Adjust the height of the tool. Use the tailstock with lathe center to adjust the tool to the required height. If necessary, use steel spacer shims under the tool to get the required height.

### Tool height

For the facing process, the cutting edge of the tool must be exactly aligned with the height of the lathe center to obtain a shoulder-free face. The facing process is a turning operation in which the turning tool feeds perpendicular to the axis of rotation of the workpiece in order to produce a flat surface. The different methods are transversal facing and transversal slicing.

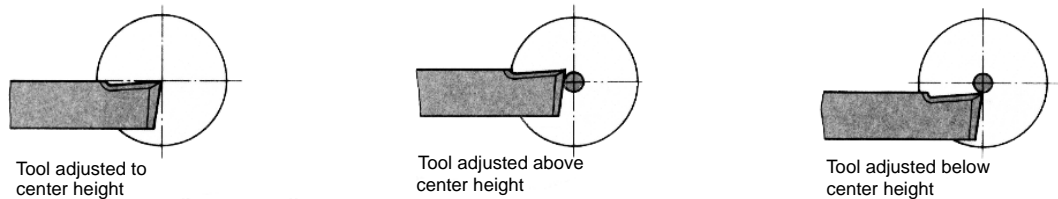

Illustr. 4-9: height of the tool

### Tool angle



#### ATTENTION!

The tool must be clamped with its axis perpendicular to the axis of the workpiece. If it is clamped at an angle, the tool may be sucked into the workpiece.

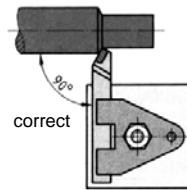

correct  
Tool clamped perpendicular to the axis of the workpiece.

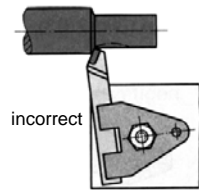

incorrect  
Tool clamped at an angle to the feed direction

Illustr. 4-10: graph: angle of the tool

### 4.6 Switching the lathe on



→ Turn the main switch on.



- The control lamp for operation must be on.



→ Check that the EMERGENCY-STOP button is not activated. Turn the EMERGENCY-STOP button to the right in order to reset it.

→ Close the lathe chuck guard.

☞ „Malfunctions“ on page 111

### 4.7 Head spindle seat

The head spindle is designed as Camlock ASA D 1-4" holding fixture.



#### CAUTION!

Regularly check the closed status of the clamp bolts.



#### INFORMATION

Mark each workpiece holder by a nick in order to facilitate the recover of the precision of the concentric run and the axial run-out deviation.

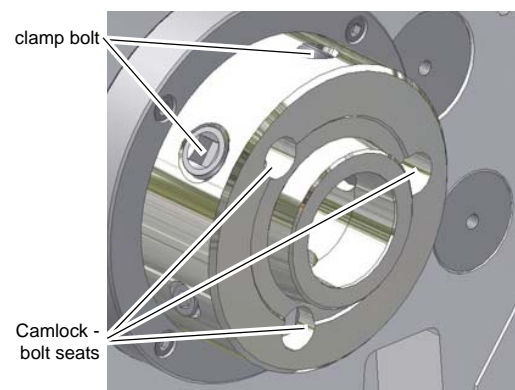

Illustr. 4-11: head spindle seat

### Fasten workpiece holder

→ Fasten the workpiece holder by turning the clamp hold clockwise.

The right clamp position is achieved when the reference marks at the clamp holder are between the two marks at the lead spindle seat.

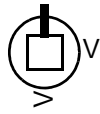

marking clamp bolt  
"open position"



marking clamp bolt  
"closed position"

Illustr. 4-12: marking Camlock bolts

## Adjusting the Camlock bolts to the workpiece holder

- Detach the safety screw.
- Turn the Camlock bolt by one complete revolution in or out, according to the correction necessary.
- Mount the safety screw.

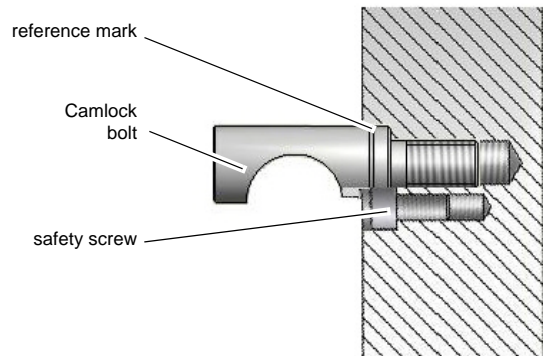

Illustr. 4-13: Camlock seat



### INFORMATION

The reference mark on each Camlock bolt serves as orientation for the right adjustment.

#### 4.7.1

### Lathe chuck

The workpieces must be clamped firmly and securely onto the lathe before they are machined. The clamp should be tight enough to ensure that the workpiece will not come out (fly out) during machining, but not so tight that it is damaged or deformed.



### WARNING!

**Do not clamp any workpieces that exceed the permitted chucking capacity of the lathe chuck. The clamping force of the chuck is insufficient if its capacity is exceeded. The jaws might break out loose and fly out.**

#### 4.7.2

### Mounting workpiece holders

#### Center

- Clean the taper bore of the head spindle holding fixture.
- Clean the Morse taper and the taper of the center.
- Press the center with the Morse taper into the taper bore of the head spindle holding fixture.

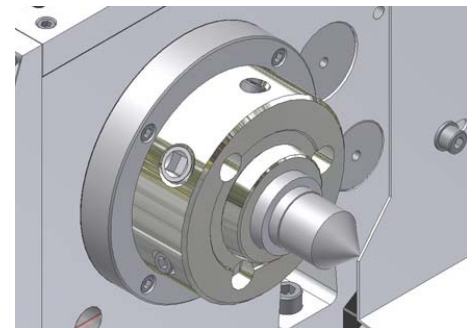

Illustr. 4-14: center

#### Three jaw chuck

- Check that the seatings at the head spindle holding fixtures at the flange for the three jaw chuck to be fitted are clean and that the supporting surfaces are not being damaged.
- Check that all clamping bolts in the head spindle holding fixture are opened.

- Mount the three jaw chuck to the head spindle seat.
- Fix the clamp bolt as described under  „Head spindle seat“ on page 37.

## Face plate

- Check that the seatings at the head spindle holding fixtures and at the flange for the three jaw chuck to be fitted are clean and that the supporting surfaces are not damaged.
- Check that all clamping bolts in the head spindle holding fixture are opened.
- Mount the face plate to the head spindle seat.

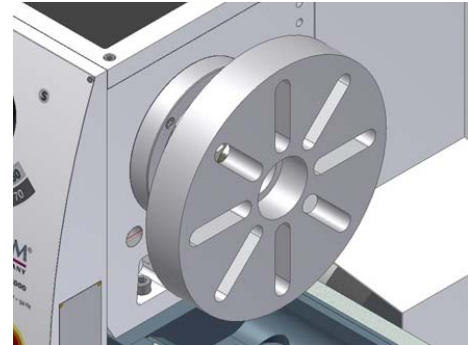

Illustr. 4-15: face plate

- Fix the clamp bolt as described under  „Head spindle seat“ on page 37.

## 4.8 Mounting of rests

### 4.8.1 Movable and steady rests

Use movable or steady rests to support long turned parts if the shear forces of the turning tool would bend the turning parts.

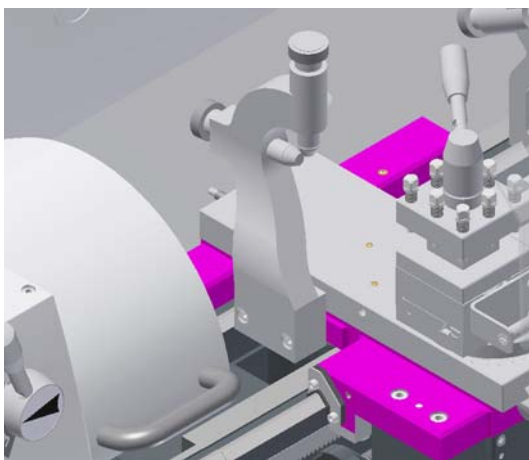

Illustr. 4-16: Movable rest

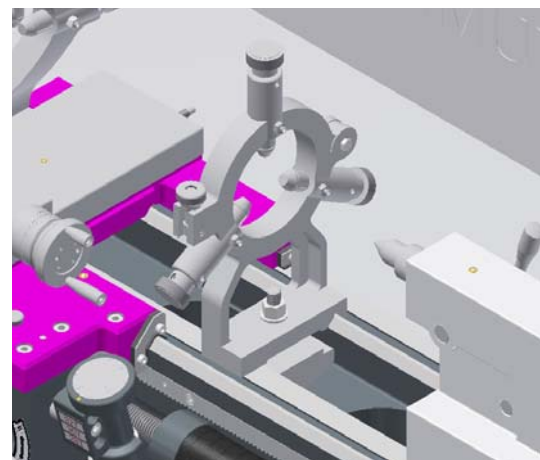

Steady rest

## 4.9 Bed insert

Remove the bed insert if the diameter of the workpiece turned is larger than 312 mm (12.28"). By removing the bed insert, the diameter turned might be increased to 430 (16.93") mm.

- First detach the fastening screws and then pull out the alignment pins.
- For reassembly, proceed the other way around.

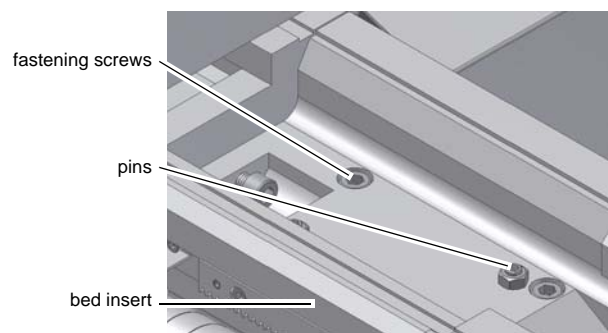

Illustr. 4-17: bed insert Feed table / Table for thread cutting

## 4.9.1 Feed table

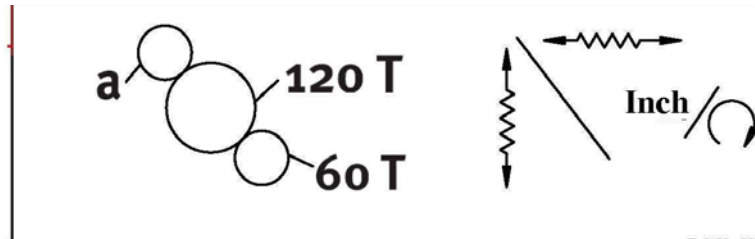

a		60T				30T			
		T	S	R	V	T	S	R	V
A	D	.0548	.0512	.0411	.0328	.0274	.0256	.0205	.0164
	D	.0187	.0175	.0140	.0112	.0094	.0087	.0070	.0056
B	D	.0274	.0256	.0205	.0164	.0137	.0128	.0102	.0082
	C	.0094	.0087	.0070	.0056	.0047	.0044	.0035	.0028
A	C	.0137	.0128	.0102	.0082	.0069	.0064	.0051	.0041
	C	.0047	.0044	.0035	.0028	.0024	.0022	.0017	.0014
B	C	.0069	.0064	.0051	.0041	.0034	.0031	.0025	.0020
	C	.0024	.0022	.0017	.0014	.0012	.0011	.0009	.0007

Illustr. 4-18: feed table D320 x 920 ; D320 x 920 DPA

### Adjust feed

Example: crossfeed 0.0035" / spindle revolution. With the same settings you will achieve a longitudinal feed of 0,261mm (0.0103") / spindle revolution.

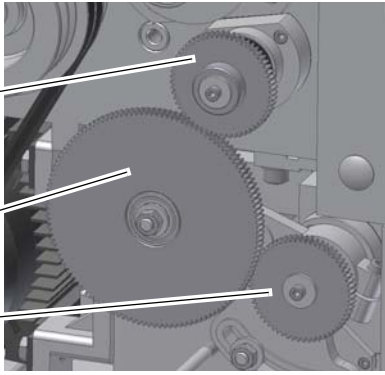

a =  
60 teeth  
120 teeth  
60 teeth

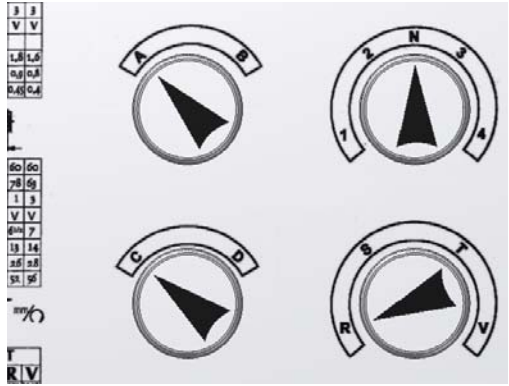

**ATTENTION!**

The change gears have to be mounted according to the layout of the feed table in order to achieve the indicated feed rate.

set selection switch to A - C - N - R  
N = neutral position  
☞ „Cutting speeds“ on page 54

If necessary, use the ☞ „Overview of control elements“ on page 32 as a reference for the following description.

- Tighten or loosen the clamping screws on the saddle in dependence on the feed used (☞ Illustr. 4-28: „lathe saddle tightening screw“ on page 45)
- Select the required feed with the "dial selectors" on the headstock.



- Activate the automatic crossfeed by pushing down the engaging lever.
- Activate the automatic longitudinal feed by pulling out and pushing up the engaging lever.
- Slightly move the handwheel of the corresponding slide to facilitate the locking of the engaging lever.

### 4.9.2 Table for thread cutting

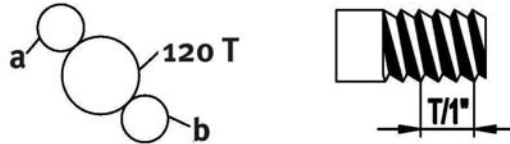

a		60	60	60	60	60	56	60	60
b		60	54	57	60	66	69	54	78
		4	1	1	1	1	1	2	1
		V	V	V	V	V	V	V	V
A	D	4	4½		5	5½		6	6½
B	D	8	9	9½	10	11	11½	12	13
A	C	16	18	19	20	22	23	24	26
B	C	32	36	38	40	44	46	48	52

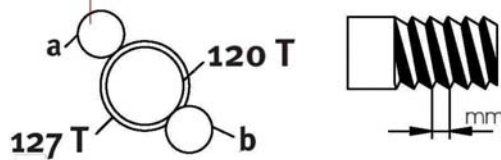



a		56	60	60	30	60	60	30	60	56
b		60	60	60	60	60	60	60	60	63
		4	1	3	4	1	3	1	3	3
		R	R	S	T	V	R	T	V	V
A	D	7.0	6.0		5		4.5	4.0		
B	D	3.5	3.0		2.5		2.25	2.0	1.8	1.6
A	C	1.75	1.5	1.4	1.25	1.2		1.0	0.9	0.8
B	C		0.75	0.7		0.6		0.5	0.45	0.4

Illustr. 4-19: table for thread cutting D320

## Adjusting threads

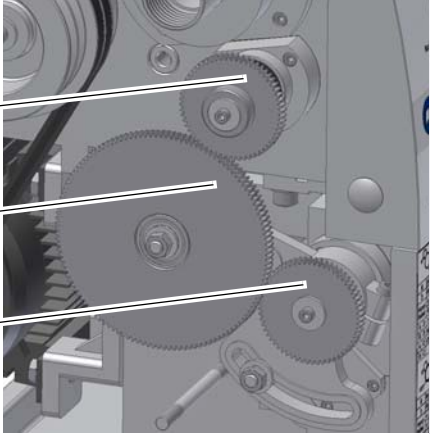
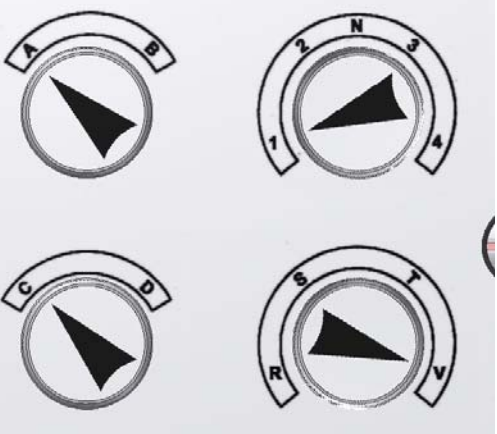
Example: thread pitch 13 TPI (threads per inch)

	
 <p><b>ATTENTION!</b> The change gears have to be mounted according to the layout of the feed table in order to achieve the indicated feed rate.</p>	<p>Set selection lever to B - D - 1 - V</p>

### 4.9.3 Replacement, change of position of the change gears

The change gears for the feed are mounted to a quadrant or directly on the leadscrew and on the feedgear mechanism.



→ Disconnect the lathe from main power source and secure the main switch by a padlock against unauthorized or accidental activation.



- Open the protective cover of the change gears.
- Loosen the two clamping screws of the quadrant.
- Turn the quadrant down.
- Mount and position the change gears as indicated in the table.

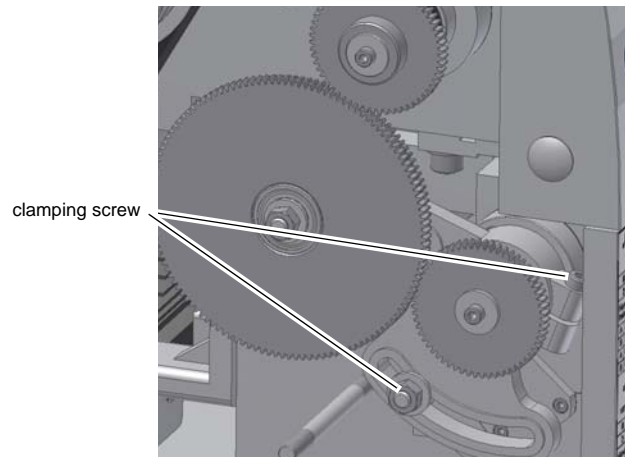

Illustr. 4-20: change gears

**Example:**

- Loosen the screws of the change gear **b** and the nut on the shaft of the intermediate gears.
- Replace the change gear **b** according to the change gear table.
- Adjust the intermediate wheels in the elongated hole of the quadrant until gears are engaged.
- Position the quadrant in a way that the intermediate gear is engaged with gear **a** again.

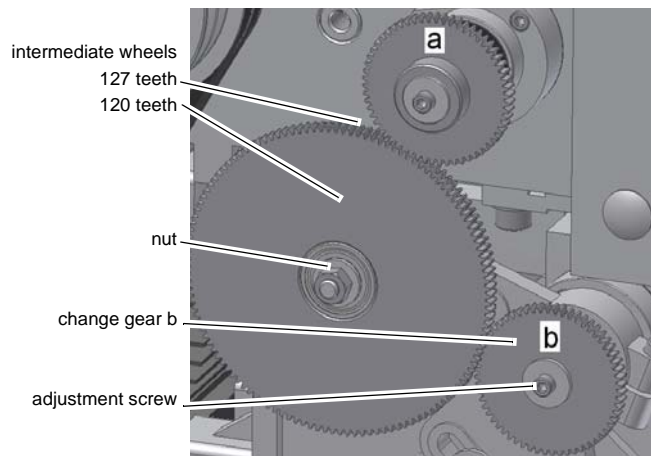

Illustr. 4-21: change gear

- Flip the change gear **a** or **b** by 180° in order to achieve the engagement with the intermediate gear 127 teeth.



**INFORMATION**

Set the clearance of the tooth profile by using a sheet of paper (80g/m<sup>2</sup>). Clamp the paper as a distance piece between the toothed profiles of the toothed wheels.

**4.9.4**

**Threading gauge**

The threading gauge is used to cam in the lead-screw nut in connection with the starting lever thread at the right place with the lead screw when cutting threads.



**ATTENTION!**

**Dismount or disengage connecting gear of the threading gauge when you are not cutting threads. The wear and tear of the connecting gear will be reduced considerably.**

- Loosen threading gauge pivoting bolt.
- Engage the threading gauge with the lead screw.
- Retighten the pivoting bolt.
- Compare the threads pitch which you are cutting with the indication in the table on the threading gauge.
- Engage the half nut on the number that is shown in indicator table.

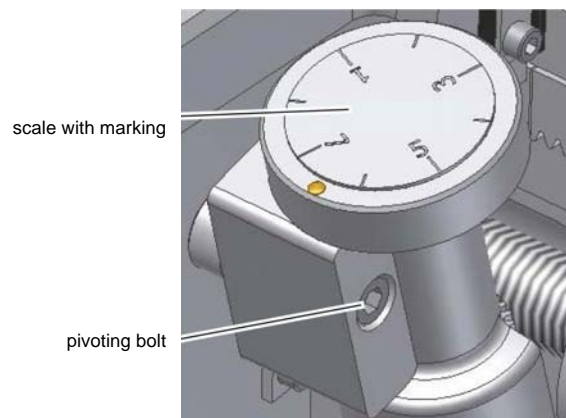

INDICATOR TABLE					
T-P-I	SCALE	T-P-I	SCALE	T-P-I	SCALE
4	1-4	13	1	44	1-4
4 1/2	1	14	1.3	46	1.3
4		16	1-8	48	1-8
5	1	18	1.3	52	1-4
5 1/2	1	19	1	56	1-8
6	1.3	20	1-4	64	1-8
6 1/2	1	22	1.3	72	1-8
7	1	23	1	76	1-4
8	1-8	24	1-8	80	1-8
9	1	26	1.3	88	1-8
9 1/2	1	28	1-4	92	1-4
10	1.3	32	1.8	96	1-8
11	1	36	1-4	104	1-8
11 1/2	1	38	1.3	112	1-8
12	1-4	40	1-8		

Illustr. 4-22: threading gauge

**Example:**

When you cutting threads with a pitch of 14 TPI (threads per inch) you can engage half nut with the lead screw when the marking on the threading gauge corresponds to the number 1 or 3 only.

When you cutting threads with a pitch of 12 TPI (threads per inch) you can engage half nut with the lead screw only when the marking on the threading gauge corresponds to the number 1, 2, 3 or 4.

**4.10 Tailstock**

The tailstock sleeve is used to hold the tools (bits, centers, etc.)

- Install the required tool in the tailstock sleeve.
- Use the scale on the sleeve to re-adjust and / or adjust the tool.
- Clamp the sleeve with the clamping lever.

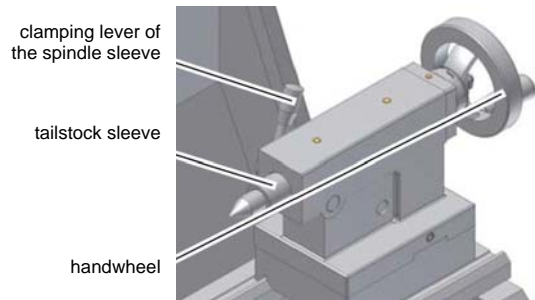

Illustr. 4-23: tailstock

Use the handwheel to move the sleeve back and forth.

The sleeve of the tailstock can be used to mount a drill chuck for holding bits and countersinks.

**4.10.1 Cross-adjustment of the tailstock**

The cross-adjustment of the tailstock is used for turning taper on long, thin shafts.

- Loosen the clamping set screw in the rear of the tailstock.
- Loosen the adjusting screws in the front and in the back of the tailstock.
- By alternating loosening and tightening the two (front and back) adjusting screws, the tailstock is moved out of the central position. The desired cross-adjustment can be read off the scale.

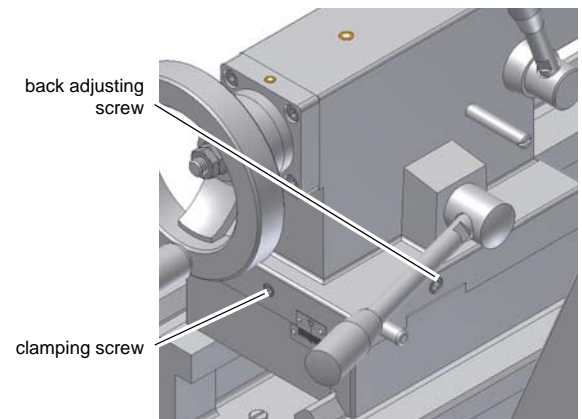

Illustr. 4-24: cross-adjustment of the tailstock

- Retighten the adjusting screws and the clamping screw of the tailstock.

**INFORMATION**

The tailstock may be cross-adjusted to each direction by approximately 10 mm (3/8") in each direction.

Example:

A 300 mm (11.811") long shaft is to be taper-turned between the centers with an angle of 1°.

Cross-adjustment of the tailstock = 300 mm (11.811") x Tan 1°. The tailstock must be cross-adjusted by about 5,236 mm (0.206").



**CAUTION!**

**Check clamping of the tailstock and the sleeve, respectively for the turning jobs between the centers!**

**Fit the stop bolt at the end of the lathe bed in order to prevent the tailstock from falling off the lathe bed.**

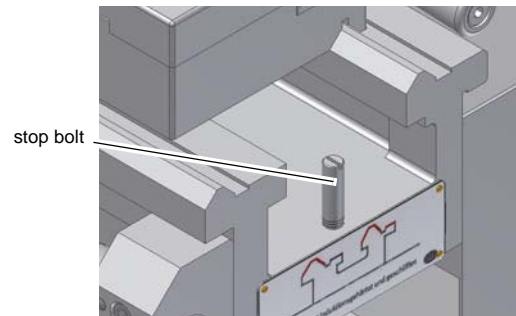

Illustr. 4-25: lathe bed

## 4.11 General working notes

### 4.11.1 Straight turning

In the straight turning operation, the tool feeds parallel to the axis of rotation of the workpiece. The feed can be either manual - by turning the handwheel on the lathe saddle or the compound slide - or by activating the automatic feed. The cross feeding for the depth of cut is achieved using the cross slide.

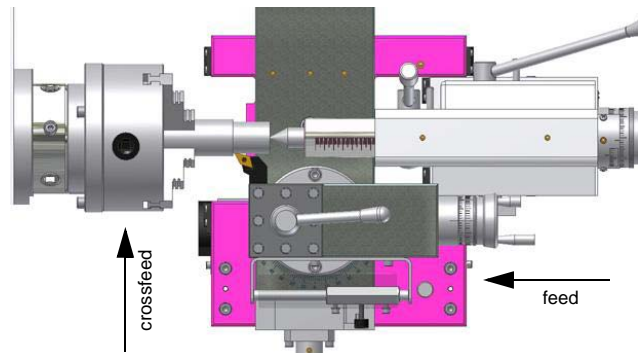

Illustr. 4-26: graph: straight turning

### 4.11.2 Facing and recesses

In the facing operation, the tool feeds perpendicular to the axis of rotation of the workpiece. Feed is manual, using the cross-slide handwheel or by activating the automatic feed. The cross feeding for depth of cut is achieved using the compound slide or lathe saddle.

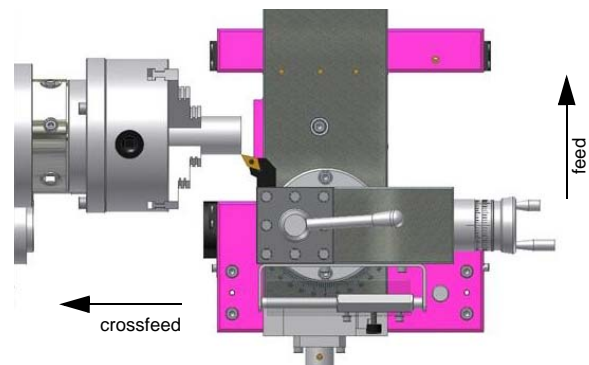

Illustr. 4-27: graph: facing operation

### 4.11.3 Fixing the lathe saddle

The cutting force produced during facing, recessing or slicing process may displace the lathe saddle.

➔ Secure the lathe saddle using the tightening screw.

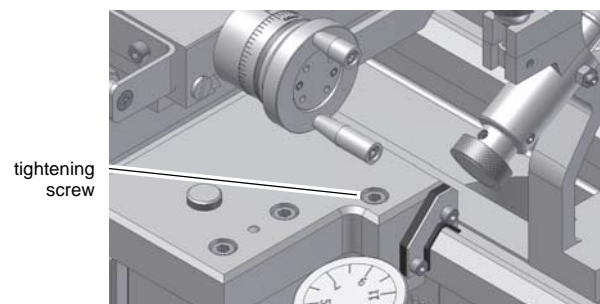

Illustr. 4-28: lathe saddle tightening screw

## 4.11.4 Turning between centers

Workpieces that require a high accuracy and precision are machined between the centers. For holding purposes, a center hole is drilled into both plain machined faces of the workpiece.

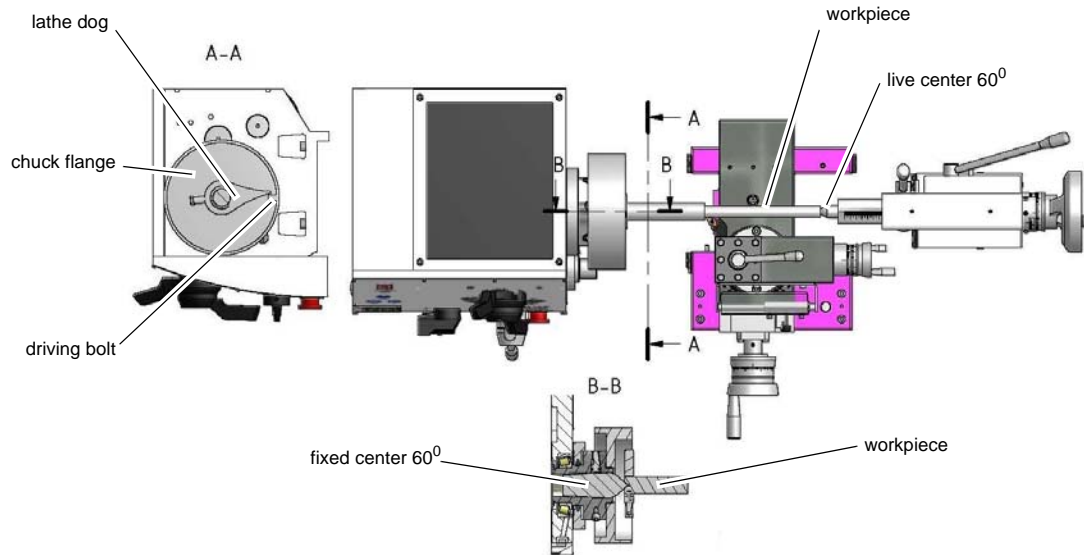

Illustr. 4-29: graph: turning between centers

The lathe dog is clamped onto the workpiece. The driving bolt screwed into the flange for the lathe chuck to transmit the torque to the lathe dog.

The fixed center glides into the center hole of the workpiece on the spindle nose side. The live center glides into the center hole of the workpiece at the tailstock side.

## 4.11.5 Turning short tapers with the compound slide

Short tapers are turned manually with the compound slide. Swivel the compound slide to the required angle. The cross feeding is performed with the cross slide.

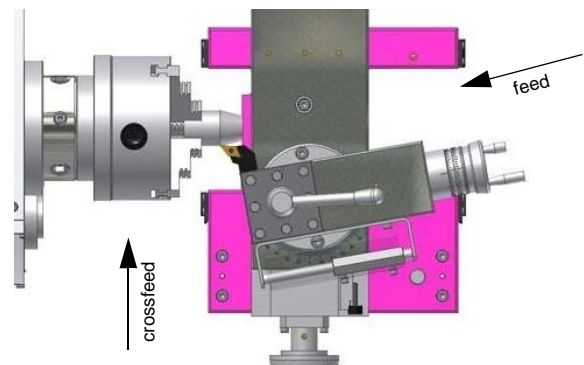

Illustr. 4-30: graph: taper turning

- Loosen the two clamping screws in the front and in the rear of the compound slide.
- Swivel the compound slide.
- The required setting of the angular degree may be read from the scale.
- Clamp the compound slide again.

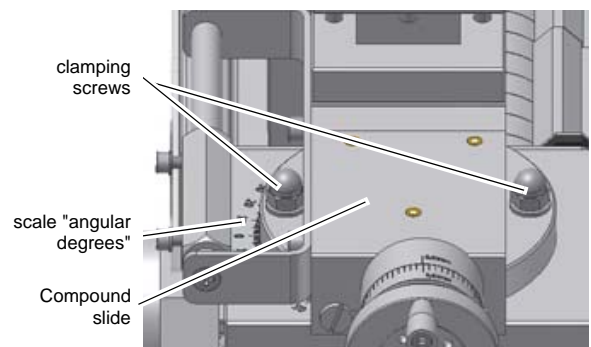

Illustr. 4-31: Compound slide

## 4.11.6 Thread-cutting

The thread-cutting process requires that the operator has a good knowledge of turning and sufficient experience.



### NOTES!

#### Example of a male thread:

- The workpiece diameter must have been turned to the diameter of the desired thread.
- The workpiece requires a chamfer at the beginning of the thread and an undercut at the thread runout.
- The speed must be as low as possible.
- The thread cutting tool must be exactly the same shape as the thread, it must be absolutely rectangular and must be clamped in a way that it coincides exactly with the turning center.
- The leadscrew nut (engaging lever) must be engaged during the whole thread-cutting process.
- The thread is produced in various cutting steps in a way that the cutting tool has to be turned out of the thread completely (with the cross slide) at the end of each cutting step.
- The tool is withdrawn with the lead-screw nut engaged and the thread cutting tool disengaged by inverting the change-over switch.
- Stop the lathe and feed the thread cutting tool in low cut depths using the cross slide.

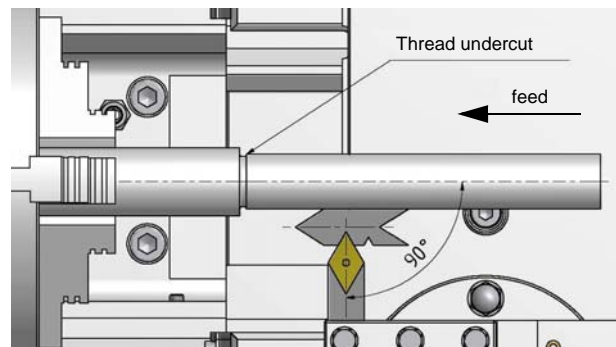

Illustr. 4-32: graph: thread-cutting

Before each passage, place the compound slide approximately 0,2 to 0,3 mm (0.008 to 0.012") to the left and right alternately. This way, the thread cutting tool cuts only on one thread flank with each pass

## 4.11.7 Coolant

Friction during the cutting process causes high temperatures at the cutting edge of the tool. The tool should therefore be cooled during the cutting process. Cooling the tool with a suitable cooling lubricant ensures better working results and a longer edge life of the cutting tool.



### INFORMATION

Use a water-soluble and non-pollutant emulsion as a cooling agent. This can be acquired from authorized distributors.



Make sure that the cooling agent is properly retrieved. Respect the environment when disposing of any lubricants and cooling agents. Follow the manufacturer's disposal instructions.

## 4.12 Mounting of optional accessories



### INFORMATION

The components described below are not contained in the standard delivery volume.

## 4.12.1 Universal collet chucking attachment

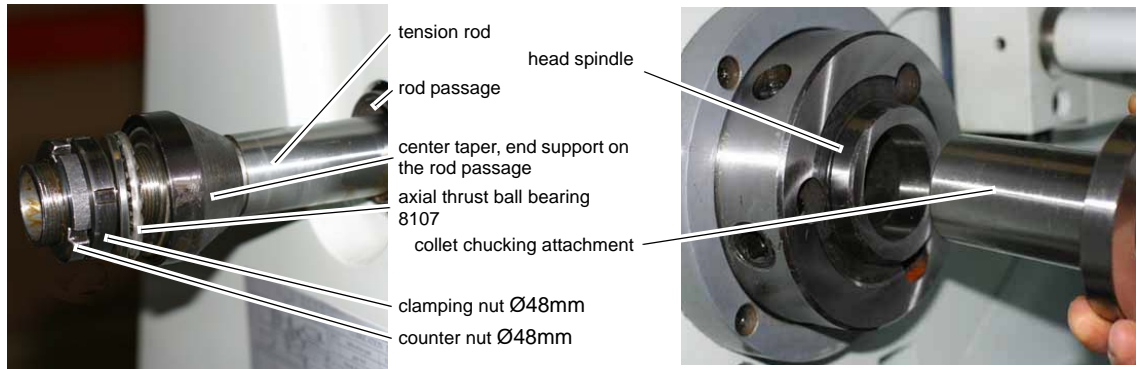

Illustr. 4-33: universal collet chucking attachment 5C



### INFORMATION

For the clamping and detaching of the collet chuck with workpiece, two sickle spanners of 48mm are required.

## 4.12.2 Draw-in collet chuck Camlock D 1-4" 5C

- Check that the surfaces of the spindle seat and on the draw-in collet chuck are clean and that the supporting surfaces are not damaged.
- Check that all clamping bolts in the head spindle holding fixture are opened.
- Mount the draw-in collet chuck to the head spindle seat.



Illustr. 4-34: draw-in collet chuck D 1-4" 5C

Fix the clamp bolts as described under  „Head spindle seat“ on page 37.

## 4.12.3 Positioning impact position with fine adjustment



### ATTENTION!

The saddle stop is not determined to be an absolute end position for automatic longitudinal feed. Only use the saddle stop position in connection with the manual movement of the lathe saddle.



Illustr. 4-35: saddle stop



### INFORMATION

The saddle stop is designed as universal positioning impact position for several lathes. If necessary, turn the clamping plate by 180° in order to achieve a clamping. If necessary, use hexagon screws if there is no shortened hexagon socket head screws. If necessary, use an additional clamping base to clamp the tools in the quadruple tool holder if the clamping distance is too large.



## 4.13 Turning Speeds & Feeds

There are rules and principles of cutting speeds and RPM (revolutions per minute) calculations that apply to all metal cutting operations. The operating speed for all metal cutting operations is based on the cutting tool material and the hardness of the material to be cut. The hardness of the work material has a great deal to do with the recommended cutting speed. The harder the work material, the slower the cutting speed. The softer the work material, the faster the recommended cutting speed Fig.4-36: "Recommended cutting speed" on page 49.

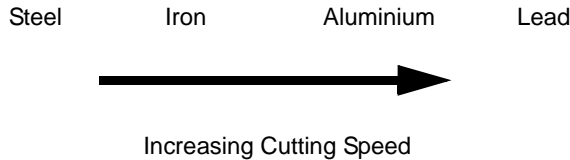

Fig.4-36: Recommended cutting speed

The hardness of the cutting tool material influences recommended cutting speed as well. The harder the cutting tool material, the faster the cutting speed. The softer the cutting tool material, the slower the recommended cutting speed Fig.4-37: "Recommended cutting speed" on page 49.

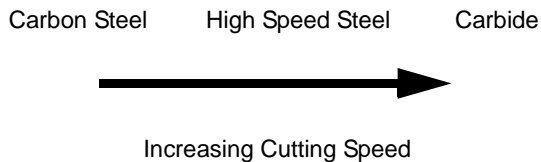

Fig.4-37: Recommended cutting speed

The depth of the cut and the feed rate will also affect the cutting speed, but not to as great as the workpiece hardness. These three factors, cutting speed, feed rate and depth of cut, are known as cutting conditions. Cutting conditions are determined by the machinability rating. Machinability is the comparing of materials on their ability to be machined. From machinability ratings you can derive recommended cutting speeds. Recommended cutting speeds are given in charts. These charts can be found in your Machinery's Handbook or in a chart given to you by your tool salesperson. In Table 3 you will find a typical recommended cutting speed chart.

## 4.14 Recommended Cutting Speeds in Feet per Minute for Turning Ferrous and Nonferrous Metals\*

Material	Condition	Hardness HB	Cutting Speed, fpm	
			High-Speed Steel	Carbide
<i>Free Machining, Plain Carbon Steels (Resulphurized)</i> AISI B1111, B1112, B1113, 1113, 1119, 1212, 1213	HR, A	100 to 150	160	500
	CD	150 to 200	180	600
AISI 1108, 1115, 1118, 1120, 1126	HR, A	100 to 150	140	450
	CD	150 to 200	150	500
AISI 1132, 1137, 1140, 1145, 1151	HR, A, N, CD	175 to 225	130	500
	Q & T	275 to 325	90	250
	Q & T	325 to 375	50	175
	Q & T	375 to 425	30	140

Material	Condition	Hardness HB	Cutting Speed, fpm	
			High-Speed Steel	Carbide
Plain Carbon Steels AISI 1012, 1015, 1018, 1019, 1020, 1022, 1024, 1025	HR, A, N, CD	100 to 125	140	500
	HR, A, N, CD	125 to 175	120	400
	HR, A, N, CD	175 to 225	100	350
	CD	225 to 275	70	300
AISI 1027, 1029, 1030, 1032, 1035, 1037, 1040, 1043, 1045, 1047, 1050	HR, N, A, CD	125 to 175	120	400
	HR, N, A, CD	175 to 225	100	350
	N, CD, Q & T,	225 to 275	70	300
	N, Q & T	275 to 325	60	240
	Q & T	325 to 375	50	200
	Q & T	375 to 425	40	175
AISI 1055, 1060, 1065, 1070, 1074, 1080, 1085, 1090, 1095	HR, N, A, CD	125 to 175	100	375
	HR, N, A, CD	175 to 225	90	325
	N, CD, Q & T,	225 to 275	65	275
	N, Q & T	275 to 325	55	225
	Q & T	325 to 375	45	180
	Q & T	375 to 425	30	150
<i>Free Machining Alloy Steels</i> (Resulphurized)  AISI 3140, 4140, 4150, 8640	HR, N, A, CD	175 to 200	125	450
	HR, N, A, CD	200 to 250	100	400
	Q & T	250 to 300	70	325
	Q & T	300 to 375	60	225
	Q & T	375 to 425	40	150
<i>Alloy Steels</i>  AISI 1320, 2317, 2512, 2517, 3115, 3120, 3125, 3310, 3316, 4012, 4017, 4023, 4028, 4320, 4615, 4620, 4720, 4815, 4820, 5015, 5020, 5024, 5120, 6118, 6120, 6317, 6325, 6415, 8115, 8615, 8620, 8625, 8720, 8822, 9310, 9315	HR, A, CD	150 to 175	110	400
	HR, A, N, CD	175 to 220	80	350
	CD, N, Q & T	220 to 275	70	300
	N, Q & T	275 to 325	60	250
	N, Q & T	325 to 375	50	200
	Q & T	375 to 425	40	175

\* Based upon a feed of 0.012 inch per revolution and a depth of cut 0.125 inch.

Material Condition: HR - Hot Rolled, A - Annealed, N - Normalized, CD - Cold Drawn or Cold Rolled, Q & T - Quenched and Tempered, AC - As Cast, ST & A - Solution Treated and Aged.

The lathe RPM must be set so that the cutting tool will be operating at the correct cutting speed. To set the proper speed, you need to calculate the proper revolution per minute or RPM setting.

## 4.15 Calculating RPM

The RPM setting depends on the cutting speed and the diameter of the part. The RPM setting will change with the diameter of the part. As the diameter of the part gets smaller, the RPM must increase to maintain the recommended surface feed. Conversely, as the diameter of the part gets larger, the RPM must decrease. Therefore, to maintain the recommended cutting speed, larger diameter parts must be run at slower speeds than a smaller diameter part.

To calculate the proper RPM for the tool and the workpiece, the following formula should be used:

$$\frac{\text{Cutting Speed (Cs) x 4}}{\text{Part Diameter (D)}}$$

This simplified version of the RPM formula can be used for other machining operations as well.

Let's use this formula to work in calculating the RPM for the machining example below. Use the recommended cutting speed charts  „Recommended Cutting Speeds in Feet per Minute for Turning Ferrous and Nonferrous Metals\*\*“ on page 49.

A cut is to be made with a high-speed steel (HSS) tool on a 2-inch diameter piece of 1018 steel with a Brinell Hardness of 150 HB. Calculate the RPM setting to perform this cut.

Cutting Speed (CS) = 120 fpm

Diameter of part (D) = 2"

$$\text{RPM} = \frac{\text{Cs x 4}}{\text{D}} = \frac{120 \times 4}{2} = \frac{480}{2} = 240 \text{ RPM}$$

Since the available spindle speed settings are generally not infinitely variable, the machine cannot be set precisely to the calculated RPM setting. Some judgment must be made in selecting the speed to use. Try to get to the speed which is nearest to the calculated RPM, but if you can't, consider these conditions. Are you roughing or finishing? If you are roughing, go slower. If you are finishing, go faster. What is your depth of cut? If it is a deep cut, go to the slower RPM setting. Is the setup very rigid? Go slower for setups that lack a great deal of rigidity. Are you using coolant? You may be able to go to the faster of the two settings if you are using coolant.

The greatest indicator of cutting speed is the color of the chip. When using a high-speed steel cutter the chips should never be turning brown or blue. Straw-colored chips indicate that you are on the maximum edge of the cutting speed for your cutting conditions. When using carbide, chip colors can range from amber to blue, but never black. A dark purple color will indicate that you are on the maximum edge of your cutting conditions.

Let's try some other examples:

A cut is to be taken with a (HSS) turning tool on a 1/2 inch piece of 1045 steel with a Brinell Hardness of 250 HB. Calculate the RPM setting to perform this cut.

Cutting Speed (CS) = 70 fpm

Diameter of part (D) = 0.5"

$$\text{RPM} = \frac{\text{Cs x 4}}{\text{D}} = \frac{70 \times 4}{0.5} = \frac{280}{0.5} = 560 \text{ RPM}$$

A 3/8-inch (HSS) drill is used on a 4-inch diameter piece of 1012 steel with a hardness of 100 HB. Calculate the RPM setting to perform this drilling operation.

Cutting Speed (CS) = 140 fpm

Diameter of the drill (D) = 0.375"

$$\text{RPM} = \frac{\text{Cs x 4}}{\text{D}} = \frac{140 \times 4}{0.375} = \frac{560}{0.375} = 1493 \text{ RPM}$$

Note that the diameter of the drill and not the workpiece was used for RPM calculation. This was done because the cutting takes place at the diameter of the drill, not on the outside diameter of the workpiece.

A turning operation is to be done on a 3.00-inch piece of 4140-alloy steel with a hardness of 200 HB. A carbide turning tool is to be used. Calculate the RPM setting to perform this cut.

Cutting Speed = 400 fpm

Diameter of part = 3"

$$\text{RPM} = \frac{\text{Cs} \times 4}{D} = \frac{400 \times 4}{3} = \frac{1600}{3} = 533 \text{ RPM}$$

## 4.15.1 Selecting Feed per Revolution

There are three factors that make up cutting conditions; cutting speed, depth of cut, and feed rate. The feed rate for turning is given in terms of inches per revolution (IPR). Inches per revolution is the rate at which the tool will advance for every revolution of the workpiece Fig.4-38: "Feed per revolution" on page 52. The feed rate is determined by the size of the chip that the tool can withstand. The feed rate in inches per tooth is also known as chip load. Because turning tools have only one cutting edge, the chip load is expressed as inch per revolution.

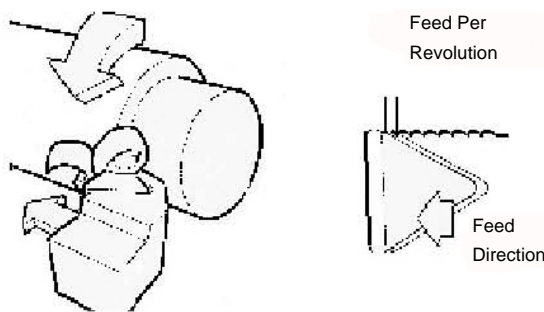

Fig.4-38: Feed per revolution

The recommended values for chip load are based on the cutting tool material and the hardness or machinability rating of the workpiece material. The recommended values for IPR (chip load) can be found in charts in the Machinery's Handbook and charts given to you by your turning tool salesperson. A typical feed in inches per revolution is shown in the "Recommended Feed Rate Selection in Inches Per Revolution for Turning" on page 53.

#### 4.15.2 Recommended Feed Rate Selection in Inches Per Revolution for Turning

Material	High-Speed Steel		Carbide	
	Roughing	Finishing	Roughing	Finishing
Low Carbon Steel	0.010 to 0.020	0.002 to 0.008	0.008 to 0.035	0.006 to 0.010
Med. Carbon Steel	0.008 to 0.018	0.002 to 0.008	0.008 to 0.030	0.006 to 0.010
High Carbon Steel	0.008 to 0.015	0.002 to 0.008	0.008 to 0.030	0.006 to 0.010
Cast Iron	0.010 to 0.025	0.003 to 0.010	0.010 to 0.040	0.008 to 0.012
Bronze	0.015 to 0.025	0.003 to 0.010	0.010 to 0.040	0.008 to 0.012
Aluminum	0.015 to 0.030	0.003 to 0.012	0.015 to 0.045	0.008 to 0.012

While the recommended feed rates found in these charts represent good fundamental machining practice, they are only recommended values. Deviations from these values may be necessary due to certain circumstances, such as long, small diameter workpieces. The feed rate used on small diameter workpieces may need to be reduced. The work-holding technique has a great deal to do with the feed rate selection. Setups, which lack rigidity, may require a slower feed rate. The distance that the unsupported part sticks out of the work-holding mechanism must be kept to a minimum to assure proper rigidity. The required workpiece finish will also affect the feed rate selection. Finer finish requirement will require a slower feed rate selection. When using carbide-turning tools, the available horsepower and the rigidity of the spindle bearings could influence the feed rate as well.

## 5 Cutting speeds

### 5.1 Choosing the right cutting speed

Given the many variables involved, it is impossible to give a universally "right" cutting speed. Tables offering standard cutting speeds should be treated with great circumspection, as they are only valid for very special cases. The recommended standard values are those laid down in the papers of the German Committee on Economic Fabrication (AWF) without cooling (no optimum values). The standard value tables given by the manufacturers of the cutting material should also be evaluated, e.g., the specifications of Friedrich Krupp Widia-Fabrik, Essen/Gemany, in the case of hard alloy cutting materials.

$v_{c60}$  is the cutting speed for a tool life of 60 min., whereas  $v_{c240}$  is the cutting speed for a tool life of 240 min. Choose  $v_{c60}$  for ordinary, easily replaceable cutting tools,  $v_{c240}$  for ordinary tool sets with mutual dependence,  $v_{c480}$  for complicated tool sets which require more time to exchange due to mutual dependency and the precision of the cutting edges. The same considerations apply to maintenance of the tools. In the case of transfer lines, even higher tool lives may be preferred.

As a general rule, higher cutting speeds save time and lower cutting speeds prolong cutting tool life.

### 5.2 Influences on the cutting speed

$v_c$  = cutting speed in [ m/min]

$\tau$  = tool life in [min]

The tool life  $\tau$  is the length of time in minutes during which the cutting edge keeps cutting until the wire edge needs to be replaced. It is of great economic importance. With the same material, the variable  $\tau$  is indirectly proportional to  $v_c$ , e.g. only a few minutes with  $v_c = 2000$  m/min. Different materials require different  $v_c$  values for the same  $\tau$ . Any considerations of this kind assume that all other cutting conditions remain the same

(materials, tools and settings). If any of these conditions changes, the  $v_c$  value will have to be changed to get the same  $\tau$ . For this reason, only cutting speed tables which provide for all possible cutting conditions are of any use.

### 5.3 Example for the determination of the required rotation speed on your lathe

The necessary rotation speed depends on the diameter of the workpiece, of the material to be machined, of the lathe tool as well as of the attitude of the lathe tool (cutting material) to the workpiece.

Material to be machined: St37

Cutting material (lathe tool): Cemented carbide

Adjusting angle [ $k_r$ ] of cutting tool to workpiece: 90°

Selected feed [f]: approx. 0.16mm per round

Required value of the cutting speed [ $v_c$ ] according to table: 180 meter per minute

Diameter [d] of your workpiece: 60mm = 0.06m [meter]

$$\text{Rotating speed } n = \frac{v_c}{\pi \times d} = \frac{180 \text{ m}}{\text{min} \times 3,14 \times 0,06 \text{ m}} = 955 \text{ min}^{-1}$$

Adjust a rotation speed which appears below determined rotation speed on your lathe.

## 5.4 Cutting speed table

Standard values for cutting speed  $v_c$  in m/min when machining high-speed steel (SS) and hard alloy. (Extract of VDF 8799, Gebr. Boehringer GmbH, Göppingen/Germany)

Material	Tensile strength $R_m$ in N/mm <sup>2</sup>	Cutting material <sup>3)</sup>	Feed $f$ in mm/rev and tool angle $k_r$ (°) <sup>1) 2)</sup>																												
			0.063			0.1			0.16			0.25			0.4			0.63			1			1.6			2.5				
			45°	60°	90°	45°	60°	90°	45°	60°	45°	60°	45°	60°	45°	60°	90°	45°	60°	90°	45°	60°	90°	45°	60°	90°	45°	60°	90°		
St 34; St 37; C22; St 42	up to 500	SS							50	40	34.5	45	35.5	28	35.5	28	22.4	28	22.4	18	25	20	16	20	16	20	16	12.5	16	12.5	10
		P 10	250	236	224	224	212	200	200	190	180	180	170	160	162	150	140	140	132	125	125	118	112	112	106	100	100	100	12.5	16	12.5
St 50; C 35	500...600	SS							45	35.5	28	35.5	28	22.4	28	22.4	18	25	20	16	20	16	12.5	16	12.5	16	12.5	10	12.5	10	8
		P 10	224	212	200	200			180	170	160	160	150	140	140	132	125	125	118	112	112	106	100	100	95	90					
St 60; C45	600...700	SS							35.5	28	22.4	28	22.4	18	25	20	16	20	16	12.5	16	12.5	10	12.5	10	8	10	8	10	8	6.3
		P 10	212	200	190	190	180	170	170	160	150	150	140	132	132	125	118	118	112	106	106	100	95								
St 70; C60	700...850	SS							28	22.4	18	25	20	16	12.5	16	12.5	10	12.5	10	8	10	8	10	8	10	8	6.3	8	6.3	5
		P 10	180	170	160	160	150	140	140	132	125	125	118	112	106	100	95	95	90	85	85	80	75								
Mn-; CrNi-, CrMo- & other alloyed steels	700...850	SS							25	20	16	20	16	12.5	16	12.5	10	12.5	10	8	11	9	7	9	7	9	7	5.6	7.5	6	4.5
		P 10	180	170	160	160	150	140	140	132	125	125	118	112	106	100	95	95	90	85	85	80	75								
	SS								20	16	12.5	16	12.5	10	12.5	10	8	10	8	6.3	5	7.1	5.6	4.5	5.6	4.5	5.6	4.5	3.6		
	P 10	140	132	125	125	118	112	100	95	90	90	85	80	71	67	63	63	60	56	56	53	50									
1000...1400	SS								14	11	9	11	9	7	9	7	5.6	7	5.6	4.5	5.6	4.5	3.6	4.5	3.6	2.8	3.6	2.8	2.2		
	P 10	80	75	71	71	67	63	63	60	56	56	53	50	50	47.5	45	45	42.5	40	33.5	33.5	31.5									
Stainless steel	600...700	P 10	80	75	71	71	67	63	56	53	50	50	47.5	45	45	42.5	40	33.5	33.5	31.5	30	28									
		SS								9	7	5.6	5.6	4.5	3.6	4	3.2	2.5													
Tool steel	1500...1800	P 10	45	42.5	40	40	37.5	35.5	35.5	33.5	31.5	28	26.5	25	25	23.4	22	22	21	20	18	17	16								
		SS																													
Mn - high-carbon steel		P 10	33.5	33.5	31.5	31.5	30	28	28	26.5	25	22	21	20	20	19	18	18	17	16											
GS-45	300...500	SS							45	35.5	28	35.5	28	22	31.5	25	20	25	20	16	20	16	12.5	16	12.5	10	12.5	10	8		
		P 10	150	140	132	118	112	106	106	100	95	95	90	85	85	80	75	75	71	67	67	63	60								
GS-52	500...700	SS							28	22	18	25	20	16	20	16	12.5	16	12.5	10	12.5	10	8	11	9	7	9	7	5.6		
		P 10	106	100	95	95	90	85	85	80	75	75	71	67	67	63	60	60	56	53	53	50	47.5								
GS-15	HB...2000	SS							45	40	31.5	31.5	28	22	22	20	16	18	16	12.5	12.5	11	9	11	10	8	9	8	6.3		
		K20	125	118	112	112	106	106	100	95	95	90	85	85	80	75	75	71	67	67	63	60									
GS-25	HB 2000...2500	SS							28	25	20	20	18	14	14	12.5	10	11	10	8	9	8	6.3	7.5	6.7	5.3	6	5.3	4.25		
		K10	95	90	85	85	80	75	75	71	67	67	63	60	60	56	53	53	50	47.5	47.5	45	42.5	42.5	40	37.5					
GTS-35 GTW-40		SS							37.5	33.5	33.5	28	26.5	25	22	21	20	18	17	16	12.5	12	11	11	10	10	9	8.5	8		
		K10/P10	95	90	85	85	80	75	75	71	67	67	63	60	60	56	53	53	50	47.5	47.5	45	42.5	42.5	40	37.5					
Chilled casting	RC420..570	K10	19	18	17	17	16	15	15	14	13.2	13.2	12.5	11.8	11.8	11.2	10.6	10.6	10	9.5	9	8.5	8	8	7.5	7.1					
		SS								53	50	47.5	47.5	45	42.5	42.5	40	37.5	37.5	35.5	33.5	31.5	30	28	28	26.5	25	25	23.6	22.4	
Cast bronze DIN 1705		K 20	315	300	280	280	265	250	250	236	224	224	212	200	200	190	180	180	170	160	160	150	140	140	132	125					
		SS								75	71	67	63	60	56	50	47.5	45	40	37.5	35.5	31.5	30	28	28	26.5	25	25	23.6	22.4	
Red bronze DIN 1705		K 20	425	400	375	400	375	355	355	335	315	335	315	300	300	280	265	265	250	236	250	236	224	236	224	212					
		SS								112	106	100	90	85	80	67	63	60	50	47.5	45	37.5	33.5	33.5	25	23.6					
Brass DIN 1709	800...1200	K 20	500	475	450	475	450	425	450	425	400	400	375	355	355	335	315	335	315	300	300	280	265	280	265	250					
		SS	125	118	112	100	95	85	75	71	67	56	53	50	42.5	40	37.5	31.5	30	28	25	23.6	22.4								
Cast aluminium DIN 1725	300...420	K 20	250	236	224	224	212	200	200	190	180	180	170	160	160	150	140	140	132	125	125	118	112	106	100	95	90				
		SS	850	800	750	800	750	710	750	710	670	670	630	600	600	600	560	560	530	500	560	560	530	500	530	500	530	500	475		
Mg alloy DIN 1729		SS																													
		K 20	1600	1500	1400	1320	1250	1250	1180	1120	1120	1120	1060	1000	1000	950	900	900	850	800	800	750	710	710	670	630	630	600	560		

- 1) The values given are valid for a cut of up to 2.24 mm. For cuts of between 2.24 mm and 7.1 mm, reduce the values by 1 level (column) in row R10 - approximately 20%. For cuts between 7.1 mm and 22.4 mm, reduce the values by 1 level in row R5 - approximately 40%.
- 2) The  $v_c$  values have to be reduced by 30 ... 50 % when turning off casting crusts and skins or in the case of sand inclusions.
- 3) The tool life  $T$  for hard alloy P10, K10, K20 = 240 min, for high-speed steel SS = 60 min.



## INFORMATION

To convert m/min (metres per minute) to FTP (feet per minute) use the following formula:

$$\text{FTP} = 3.281 \times \text{m/min}$$



## 6 Maintenance

In this chapter you will find important information about

- inspection
- maintenance
- repair of the lathe.

The diagram below shows which tasks fall under these headlines.

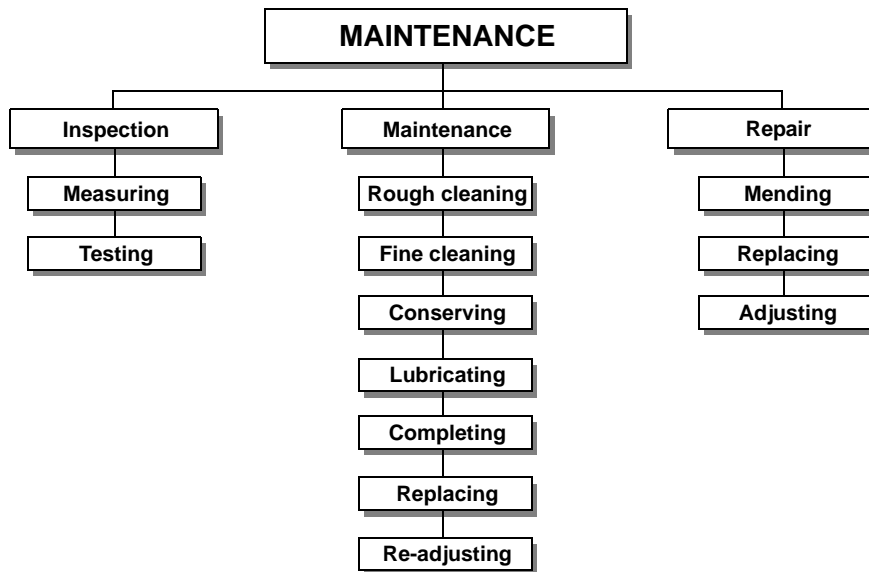

Illustr. 6-1: Maintenance - Definition according to DIN 31051



### ATTENTION!

Properly-performed regular maintenance is an essential prerequisite for

- safe operation,
- faulty-free operation,
- long service life of the lathe and
- the quality of the products to manufacture.

Installations and equipment from other manufacturers must also be in optimum condition.



### ENVIRONMENTAL PROTECTION

During work on the spindle head and on the apron, please make sure that

- collector vessels are used with sufficient capacity for the amount of liquid to be collected.
- liquid and oils should not be spilled on the ground.

Clean-up any spilled liquid or oils immediately, using proper oil-absorption methods and dispose of them in accordance with current legal requirements on the environment.

### Cleaning-up spillages

Do not re-introduce liquids spilled outside the system during repair or as a result of leakage from the reserve tank: collect them in a collecting vessel to be disposed.

### Disposal

Never dump oil or other pollutant substances in water inlets, rivers or channels.

Used oils must be delivered to a collection center. Consult your superior if you do not know where the collection center is.

## 6.1 Safety



### WARNING!

The consequences of incorrect maintenance and repair work may include:

- very serious injury to employee working on the lathe,
- damage to the lathe.

Only qualified personnel should carry out maintenance and repair work on the lathe.

### 6.1.1 Preparation



### WARNING!

Only carry out work on the lathe if it has been switched off using the main switch and secured by a padlock to prevent the lathe from being turned on again.



☞ „Switching off and securing the lathe“ on page 15

Attach a warning label.

### 6.1.2 Restarting

Run a safety check before restarting the lathe.

☞ „Safety check“ on page 13



### WARNING!

Before connecting the lathe, you must check that there is no danger for the people around and that the lathe is not damaged.

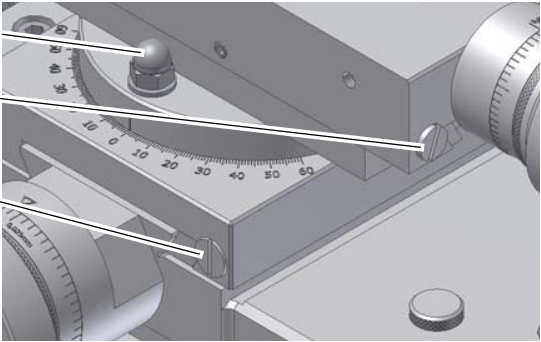

## 6.2 Inspection and maintenance

The type and extent of wear depends to a large scale on individual usage and service conditions. For this reason, all the intervals are only valid for the authorized conditions.

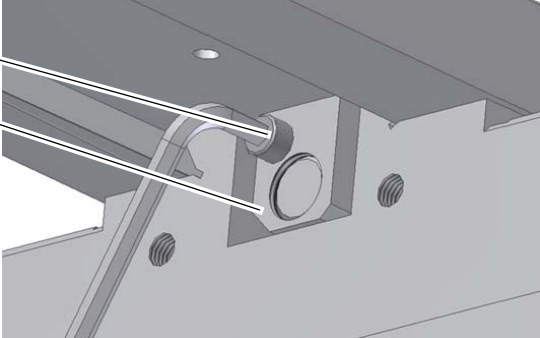
Interval	Where?	What?	How?
start of work, after each maintenance or repair operation	Lathe		☞ „Safety check“ on page 13
	Lathe	lubricate	<ul style="list-style-type: none"> <li>→ Lubricate all slideways.</li> <li>→ Slightly lubricate the change gears with lithium-based grease.</li> </ul>
	Camlock clamping bolt head spindle seat	control fastening	☞ „Mounting workpiece holders“ on page 38
as required	slideways compound slide, cross slide	re-adjust	<p>Excessive clearance in the slideways can be reduced by re-adjusting the tapered gibs.</p> <p>→ Turn the take-up screw clockwise. The tapered gib is moved inwards and reduces the clearance of the corresponding slideway.</p>  <p>locking screw</p> <p>take-up screw compound slide</p> <p>take-up screw compound slide</p> <p>Illustr. 6-2: take-up screws compound slide and cross slides</p>

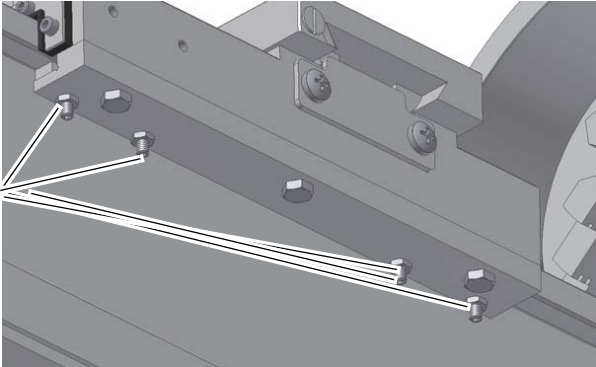
Interval	Where?	What?	How?
as required	Cross slide lead screw nut	re-adjust	<p>Excessive backlash is reduced by re-adjusting the cross slide nut.</p> <ul style="list-style-type: none"> <li>→ Disassemble the splash guard wall.</li> <li>→ Remove the cover plate at the rear of the cross slide.</li> <li>→ Turn the cross slide lead screw crank until the cross slide nut is freely accessible.</li> <li>→ Turn the socket head screw carefully and slightly clockwise in order to reduce the clearance of the cross slide lead screw nut.</li> <li>→ Grease the compound spindle.</li> </ul>  <p>Illustr. 6-3: take-up screws cross slide lead screw nut</p> <p><b>INFORMATION:</b></p> <p>One revolution of the socket head screw by quarter turn corresponds to about 0.005" compensation of the clearance. Do not reduce the clearance of the cross slide lead screw nut too much in order to avoid high wear of the nut.</p>

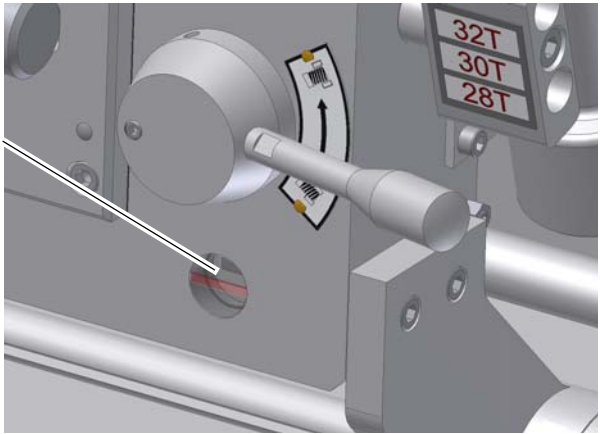
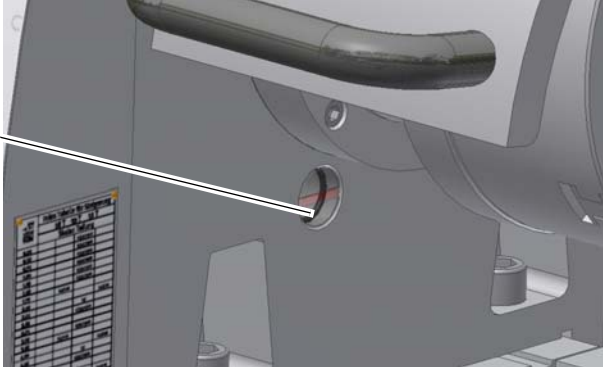
Interval	Where?	What?	How?
as required	slideway lathe saddle	re-adjust	<p>Excessive clearance in height on the saddle slideways is reduced by re-adjusting the rear gib.</p> <ul style="list-style-type: none"> <li>→ Disassemble the splash guard wall.</li> <li>→ Loosen the counter nuts of the take-up screws.</li> <li>→ Turn the take-up screws clockwise in order to reduce the clearance in height.</li> <li>→ Check your settings by moving the lathe saddle with the handwheel.</li> <li>→ Re-tighten the counter nuts.</li> </ul>  <p>take-up screws</p> <p>Illustr. 6-4: take-up screws lathe saddle</p>

Interval	Where?	What?	How?
<p style="text-align: center;">start of work after each maintenance or repair operation</p>	<p style="text-align: center;">feed gearbox / apron / headstock</p>	<p style="text-align: center;">visual inspection</p>	<p>→ Check the oil level in the inspection glass</p> <ul style="list-style-type: none"> <li>• of the feed gearbox,</li> <li>• of the apron,</li> <li>• of the headstock.</li> </ul> <p>→ It must at least reach the center line on inspection glass.   „Operating material“ on page 18.</p> <div style="display: flex; flex-direction: column; align-items: center;"> <div style="display: flex; align-items: center; margin-bottom: 10px;"> <div style="margin-right: 10px;">inspection glass apron</div>  </div> <div style="display: flex; align-items: center; margin-bottom: 10px;"> <div style="margin-right: 10px;">inspection glass headstock</div>  </div> <div style="display: flex; align-items: center;"> <div style="margin-right: 10px;">inspection glass feed gearbox</div>  </div> </div> <p style="text-align: center;">Illustr. 6-5: oil-sight glasses</p>

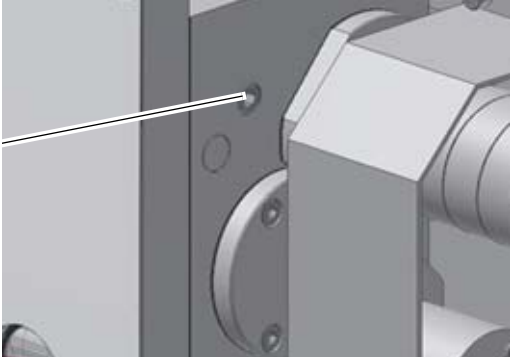
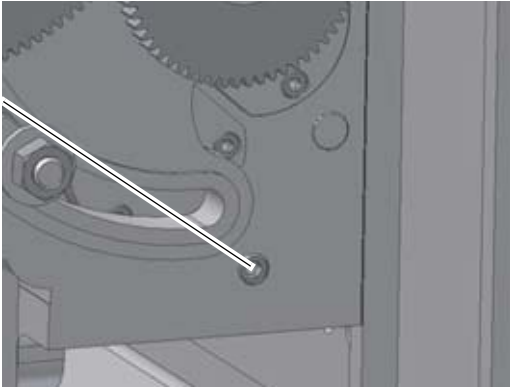
Interval	Where?	What?	How?
<p>First after 200 hours in service or three months after commissioning, then once a year</p>	<p>feed gearbox</p>	<p>oil change</p>	<ul style="list-style-type: none"> <li>→ Use an adequate collector vessel with sufficient capacity for the oil change.</li> <li>→ Unscrew the outlet oil plug.</li> <li>→ Unscrew the inlet oil plug.</li> <li>→ Close the outlet when no more oil is running off.</li> <li>→ Refill up to the reference mark in the center of the inspection glass using a suitable funnel in the filling (inlet) hole.</li> </ul> <div style="display: flex; flex-direction: column; align-items: center;"> <div style="display: flex; align-items: center; margin-bottom: 10px;"> <div style="margin-right: 10px;">feed gear inlet oil plug</div>  </div> <div style="display: flex; align-items: center;"> <div style="margin-right: 10px;">feed gear outlet oil plug</div>  </div> </div> <p style="text-align: center; margin-top: 10px;">Illustr. 6-6: feed gearbox openings</p> <p>☞ „Operating material“ on page 18</p>

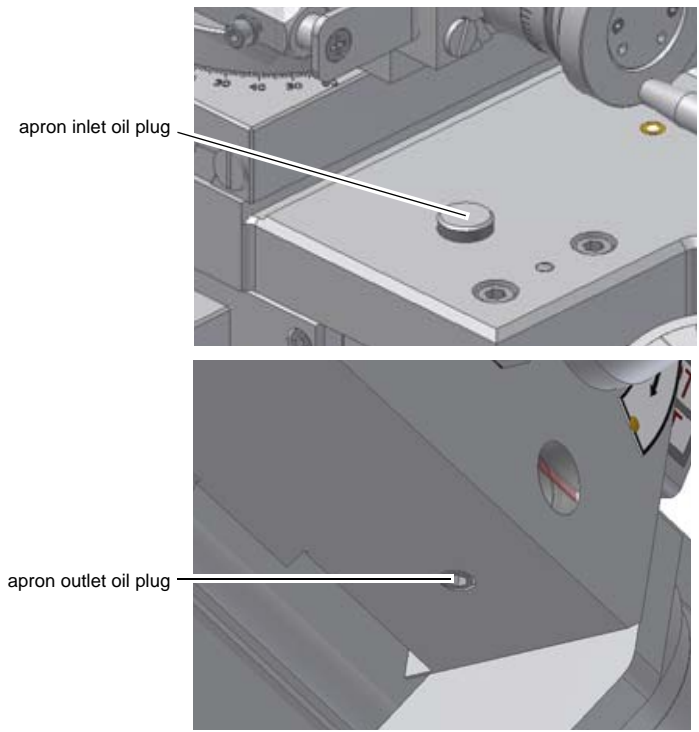
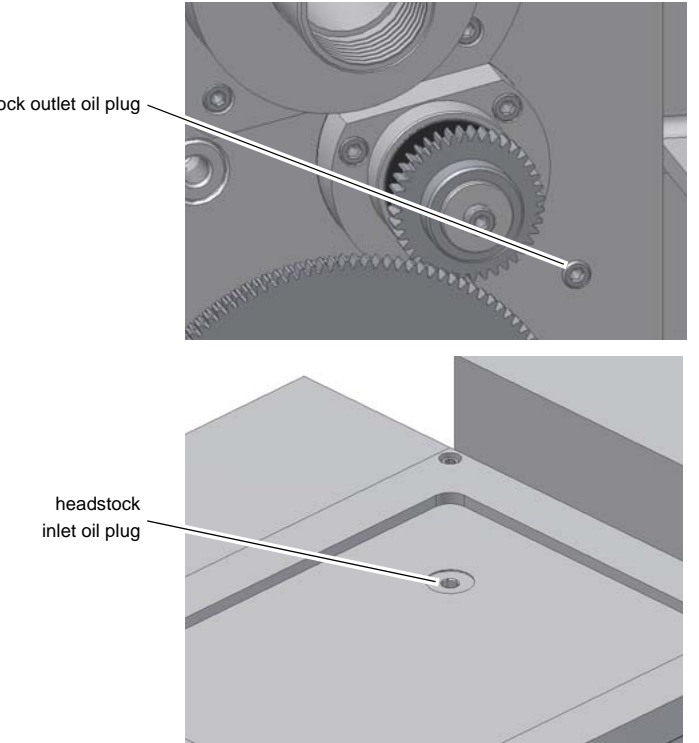
Interval	Where?	What?	How?
<p>First after 200 hours in service or three months after commissioning, then once a year</p>	<p>apron</p>	<p>oil change</p>	 <p>apron inlet oil plug</p> <p>apron outlet oil plug</p> <p>Illustr. 6-7: apron oil plugs</p>
<p>First after 200 hours in service or three months after commissioning, then once a year</p>	<p>headstock</p>	<p>oil change</p>	 <p>headstock outlet oil plug</p> <p>headstock inlet oil plug</p> <p>Illustr. 6-8: headstock oil plugs</p>

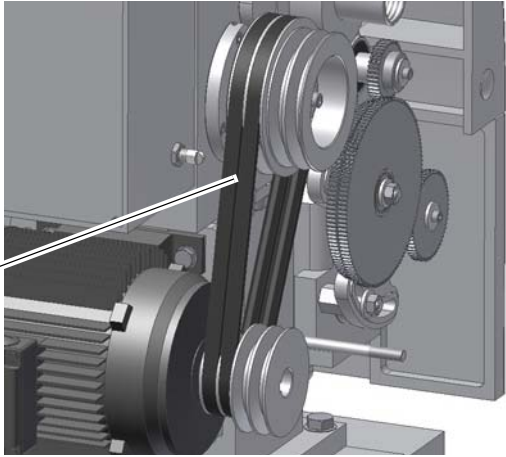
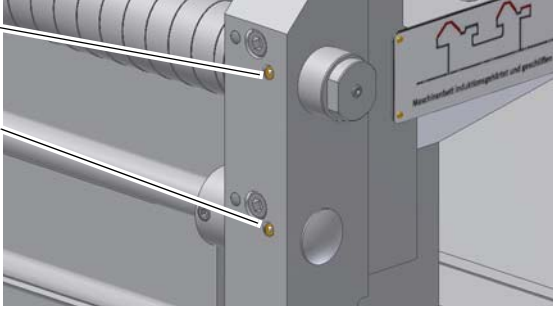
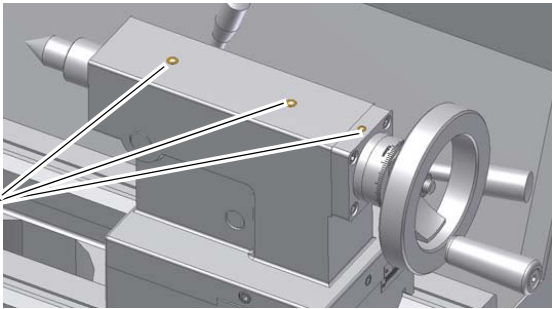
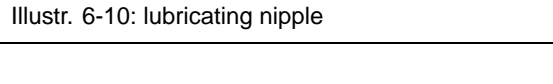

Interval	Where?	What?	How?
as required		control V-belt, tighten it	<p>Tighten the V-belt set as required.</p> <ul style="list-style-type: none"> <li>→ If necessary, exchange the complete set of V-belts only.</li> <li>→ Use the slots on the motor base to tighten the V-belts. Also refer to  „Position change of the V-belt positions“ on page 34</li> <li>→ Adjust the motor position in the way that one single V-belt may be squeezed approximately 5 mm.</li> </ul> <div style="text-align: center;">  <p>set of V-belts</p> </div> <p style="text-align: center;">Illustr. 6-9: Re-adjustment V-belts</p> <p><b>ATTENTION!</b></p> <p><b>Only exchange the complete set of V-belts, never a single one.</b></p>
weekly	leadscrew, feed shaft, tailstock	lubricate	<ul style="list-style-type: none"> <li>→ Lubricate respectively fill in all lubricating nipples and oilcups with machinery oil.</li> </ul> <div style="display: flex; flex-direction: column; align-items: center;"> <div style="display: flex; align-items: center; margin-bottom: 10px;"> <div style="margin-right: 10px;">lubricating nipples leadscrew</div>  </div> <div style="display: flex; align-items: center; margin-bottom: 10px;"> <div style="margin-right: 10px;">lubricating nipples feed shaft</div>  </div> <div style="display: flex; align-items: center;"> <div style="margin-right: 10px;">lubricating nipples tailstock</div>  </div> </div> <p style="text-align: center;">Illustr. 6-10: lubricating nipple</p>

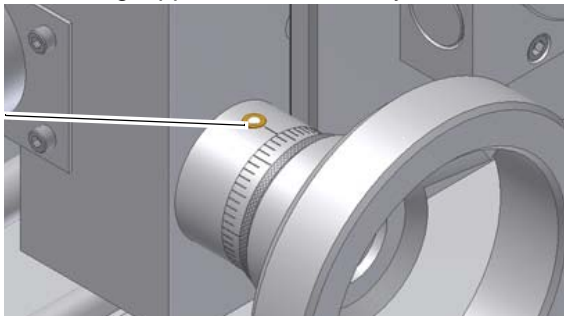
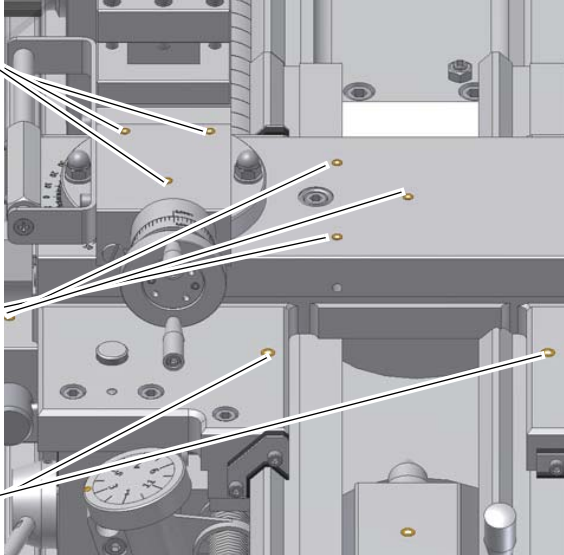
Interval	Where?	What?	How?
weekly	handwheel	lubricate	<p>→Lubricate all lubricating nipples with machinery oil.</p>  <p>Illustr. 6-11: lubricating nipple handwheel lathe saddle</p>
weekly	compound slide / compound slide	lubricate	<p>→Lubricate all lubricating nipples with machinery oil.</p>  <p>Illustr. 6-12: lubricating nipples slideways</p>



### INFORMATION

The spindle bearings are permanently greased. Greasing during the maintenance intervals is not necessary. Further greasing of the spindle bearings is only necessary in case of de- and remounting of the spindle bearing.

### 6.3 Repair

Repairs must be carried out only by qualified technical staff; and must follow the instructions and guidelines given in this manual. Should technical assistance be required, contact LDS Industries at 1-630-785-6437.

Optimum Maschinen - Germany and LDS Industries are not liable for, nor do they guarantee against, damage or operating malfunctions resulting from alteration, abuse, lack of maintenance or this product's use for other than its intended purpose. Failure to read and follow this operating manual is not covered.

For repairs only use:

- Proper and suitable tools,
- Parts purchased from Optimum, or its authorized agent.

## 7 Spare parts - D320x920, D320x920 DPA

### 7.1 Drawing spare parts headstock gear 1-6

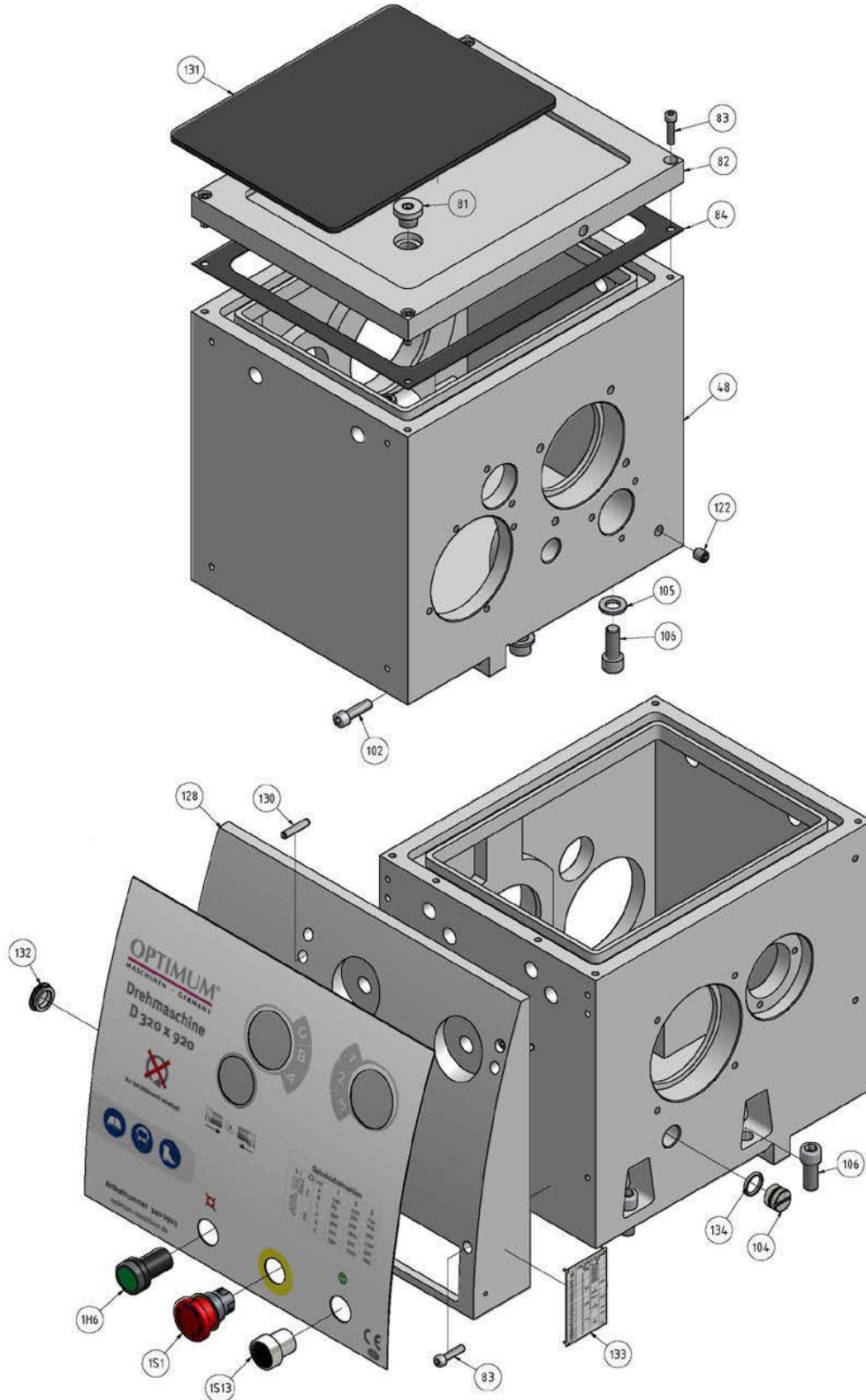

Illustr. 7-1: Headstock gear 1-6

## 7.2 Drawing spare parts headstock gear 2-6

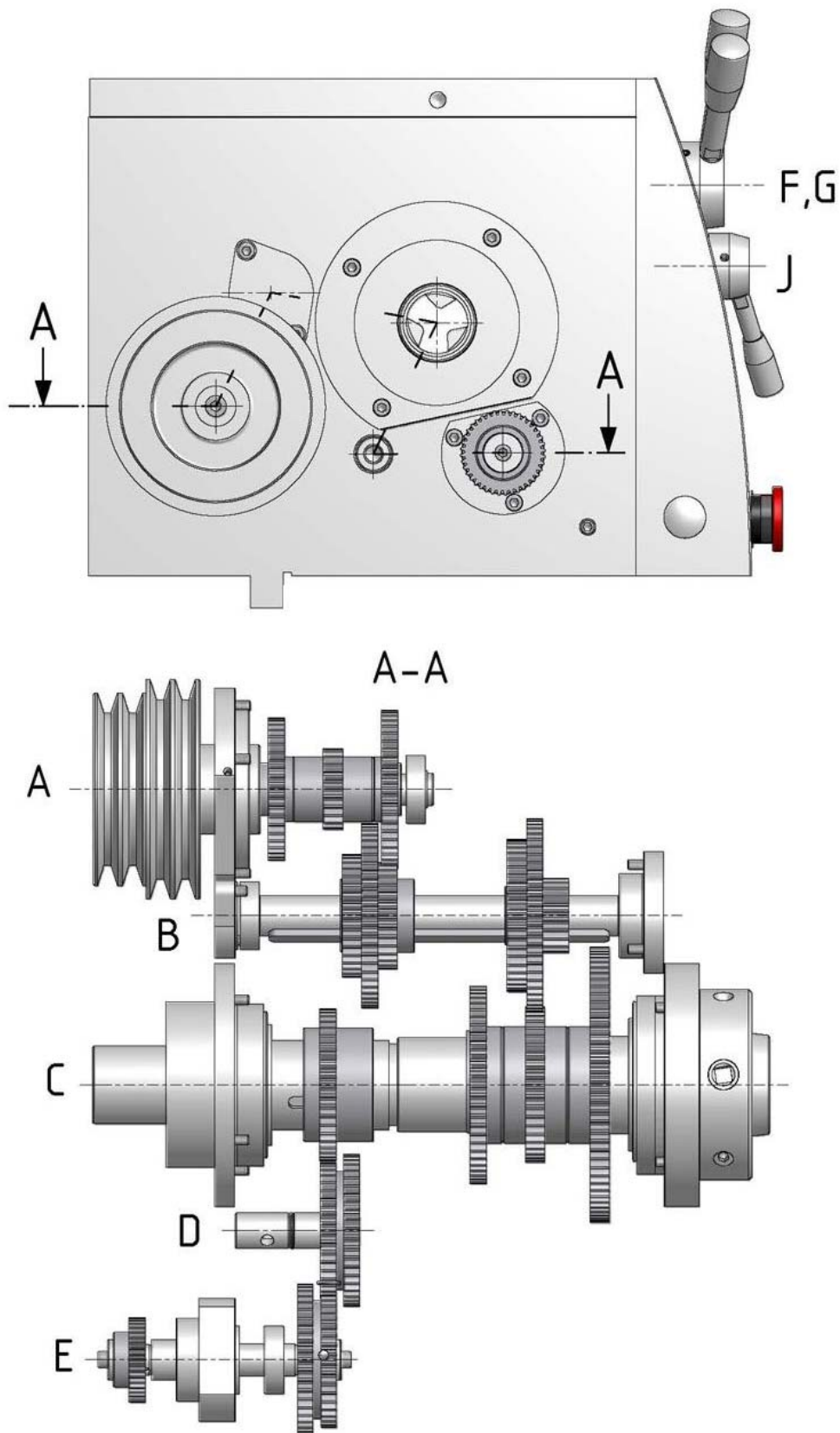

Illustr. 7-2: Headstock gear 2-6

**7.3 Drawing spare parts headstock gear 3-6**

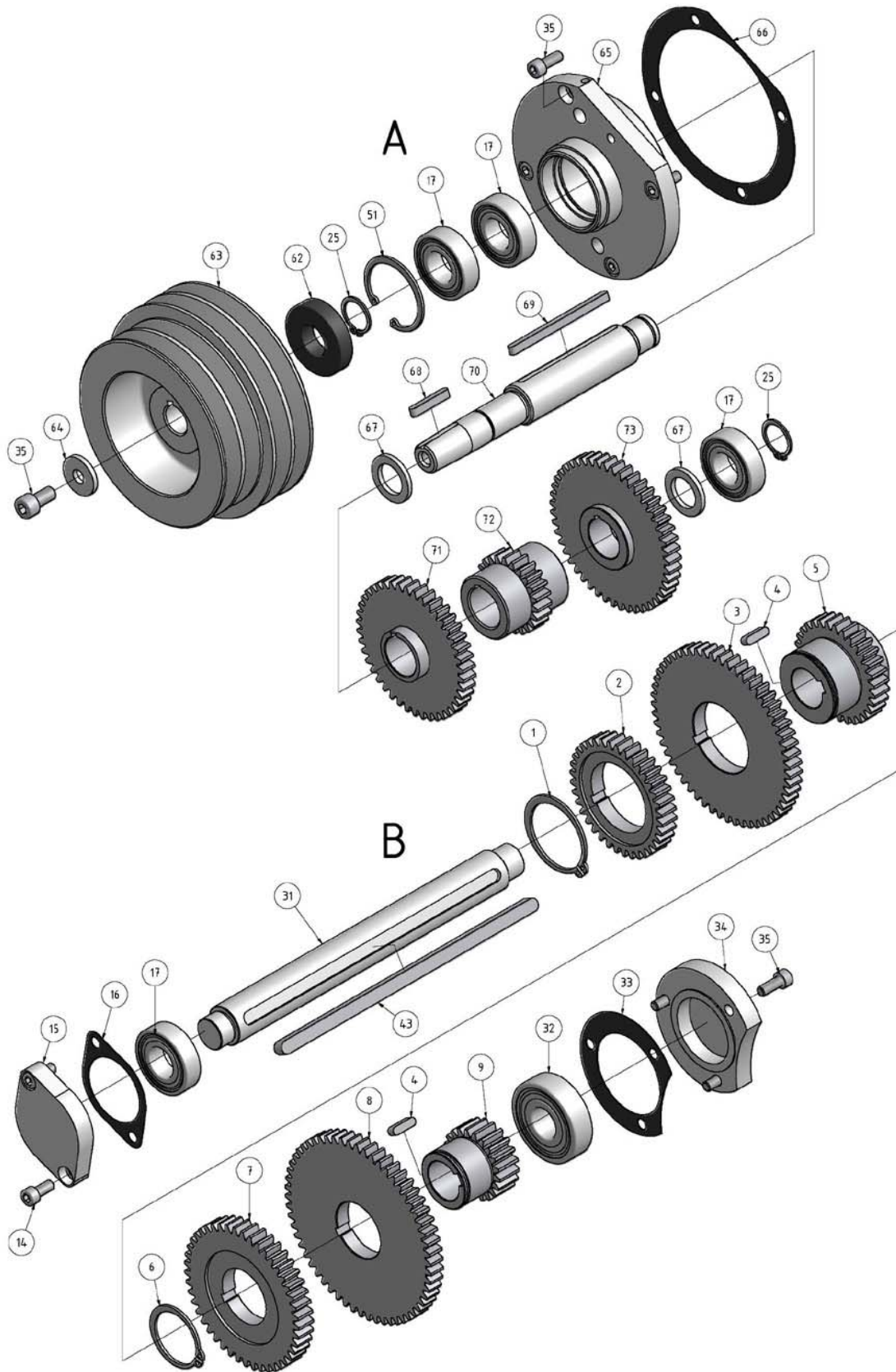

Illustr. 7-3: Headstock gear 3-6

## 7.4 Drawing spare parts headstock gear 4-6

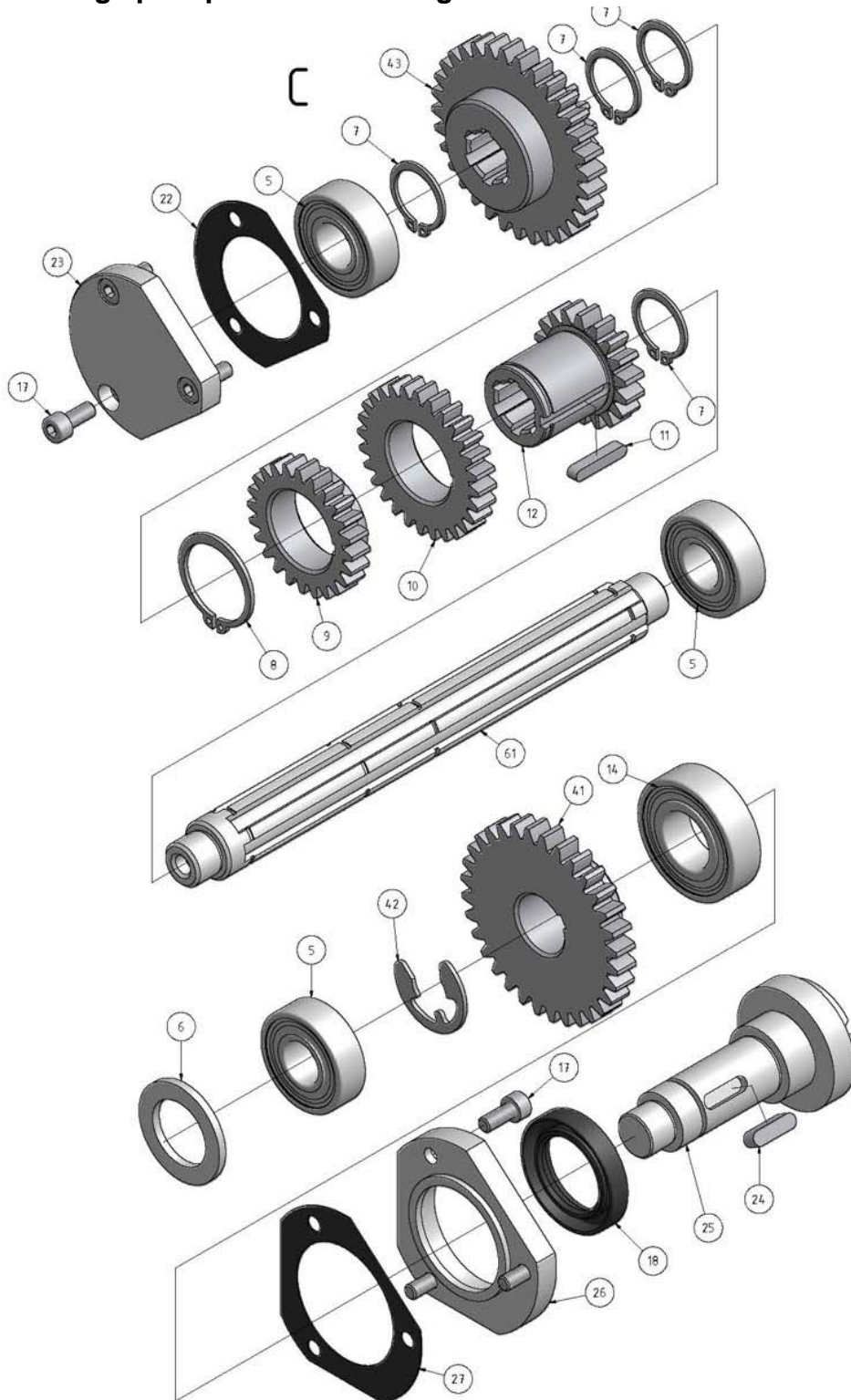

Illustr. 7-4: Headstock gear 4-6

7.5 Drawing spare parts headstock gear 5-6

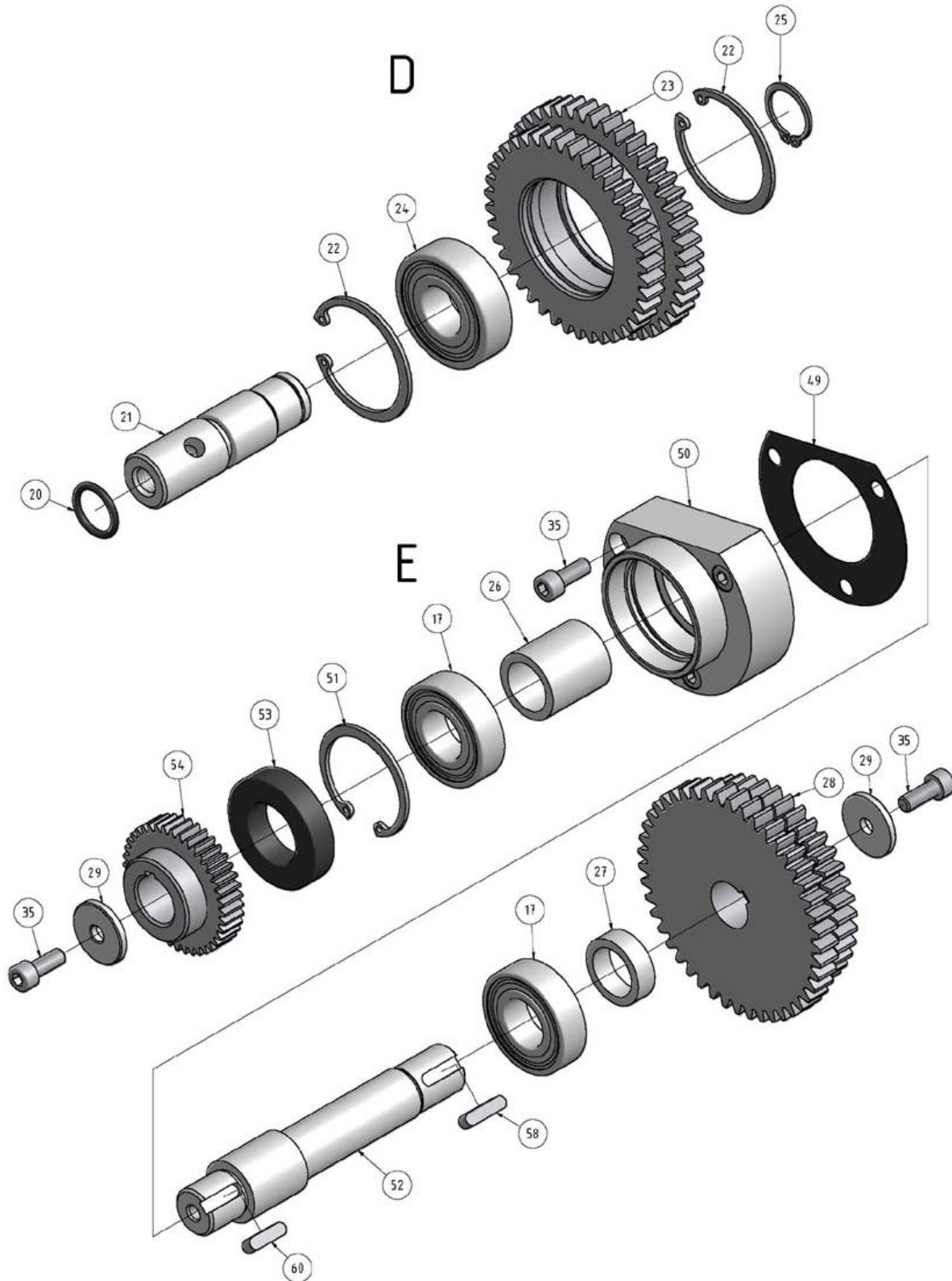

Illustr. 7-5: Headstock gear 5-6

## 7.6 Drawing spare parts headstock gear 6-6

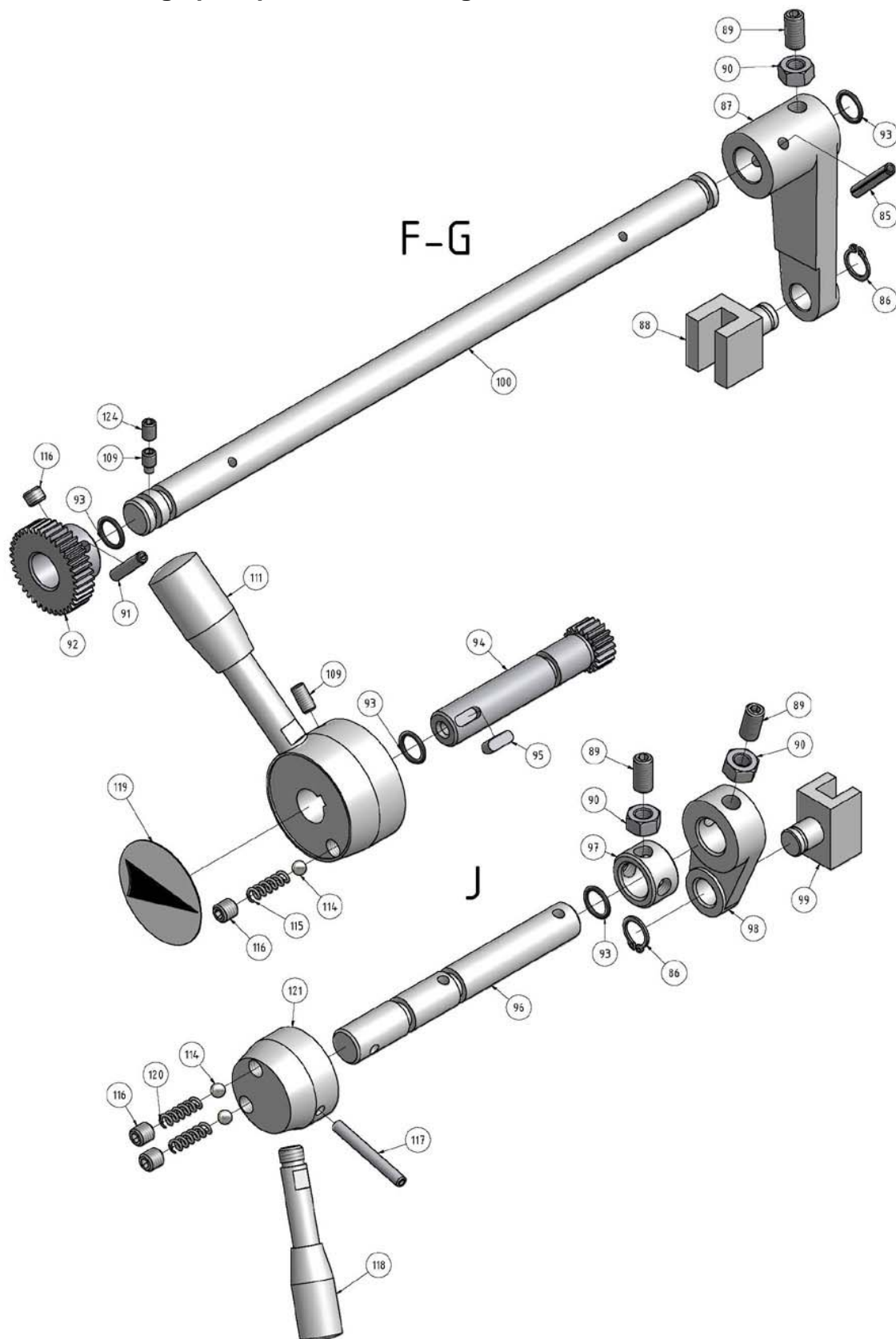

Illustr. 7-6: Headstock gear 6-6



## 7.6.1 Spare parts list headstock gear

Pos.	Description	Quantity	Size	Drawing no	Article no.
1	Retaining ring	1	GB894.1-86/45		03400923101
2	Gear	1		CQ6230-04-23a	03400923102
3	Gear	1		CQ6230-04-26	03400923103
4	Key	2	GB1096-79/5x18		03400923104
5	Gear	1		CQ6230-04-24a	03400923105
6	Retaining ring	1	GB894.1-86/36		03400923106
7	Gear	1		CQ6230-04-27a	03400923107
8	Gear	1		CQ6230-04-28	03400923108
9	Gear	1		CQ6230-04-29a	03400923109
10	Gear	1		CQ6230-04-57a	03400923110
11	Retaining ring	1	58	GB894.1-86	03400923111
12	Gear	1		CQ6230-04-34	03400923112
13	Gear	1		CQ6230-04-35	03400923113
14	Socket head cap screw	2	M6x14	GB70-85	03400923114
15	Cover	1		CQ6230-04-60	03400923115
16	Gasket	1		CQ6230-04-59	03400923116
17	Deep groove ball bearing	6	6004-2RS	GB/T276-94	03400923117
19	Gear	1		CQ6230-04-36	03400923119
20	O-Ring	1	17x2.65	GB3452.1-82	03400923120
21	Shaft	1		CQ6230C-04-51	03400923121
22	Retaining ring	2	47	GB893.1-86	03400923122
23	Gear	1		CQ6230-04-52	03400923123
24	Deep groove ball bearing	1	6004-2RS	GB/T276-94	03400923124
25	Retaining ring	3	20	GB894.1-86	03400923125
26	Collar	1		CQ6230C-04-46	03400923126
27	Collar	1		CQ6230C-04-69	03400923127
28	Gear	1		CQ6230C-04-45	03400923128
29	Washer	2		CQ6230C-04-44	03400923129
31	Shaft	1		CQ6230C-04-61	03400923131
32	Deep groove ball bearing	1	6004-2RS	GB/T276-94	03400923132
33	Gasket	1		CQ6230C-04-31	03400923133
34	Cover	1		CQ6230C-04-32	03400923134
35	Socket head cap screw	4	M6x16	GB70-85	03400923135
36	Compressing spring	3	0.6x4x22	GB2089-80	03400923136
37	Lock pin	3		C0632-04230	03400923137
38	Cam lock	3		C0632-04231	03400923138
39	Key	1	8x80	GB1096-79	03400923139
40	Key	1	8x45	GB1096-79	03400923140
41	Button head screw	1	M3x8	GB67-85	03400923141
42	Spindle	1		CQ6230C-04-40	03400923142
43	Key	1	8x210		03400923143
44	Socket head cap screw	1	M6x20	GB70 - 85	03400923144
45	Cover	1		CQ6230C-04 -39	03400923145
46	Gasket	1		CQ6230C- 04-41	03400923146
47	Taper Roller Bearing	1	30212		03400923147
48	Head Stock	1		CQ6230C-04-43	03400923148
49	Gasket	1		CQ6230C-04-50	03400923149
50	Cover	1		CQ6230C-04-47	03400923150
51	Retaining ring	2	42	GB893.1-86	03400923151
52	Shaft	1		CQ62300-04-49	03400923152
53	Oil Seal	1	PD25x45x10	HG4-692-67	03400923153
54	Gear	1		CL6232-05-41	03400923154
55	Taper roller bearing	1	30211		03400923155
56	Nut	2		C06230-04-54	03400923156
57	Key	1	C5x20	GB1096-79	03400923157
58	Gasket	1		C06230-04-58	03400923158
59	Key	1	C5x8	GB1096-79	03400923159
60	Cover	1		CQ6230-04-55a	03400923160
61	Socket head cap screw	4	M8x12	GB70-85	03400923161
62	Oil seal	1	PD20x45x10	HG4-692-67	03400923162

Pos.	Description	Quantity	Size	Drawing no	Article no.
63	Pulley	1		CQ6230-04-18	03400923163
64	Washer	1		CQ6230-04-62	03400923164
65	Cover	1		C06230-04-19a	03400923165
66	Gasket	1		CQ6230-04-20	03400923166
67	Washer	2		C06230C-04-68	03400923167
68	Key	1	C5x30	GB1096-79	03400923168
69	Key	1	5x80	GB1096-79	03400923169
70	Shaft	1		CQ6230C-04-63	03400923170
71	Gear	1		CQ6230-04-21	03400923171
72	Gear	1		CQ6230-04-22	03400923172
73	Gear	1		CQ6230-04-25	03400923173
74	Lathe chuck flanfe (optional)	1			3441538
75	3-jaw chuck (optional)	1			3441531
81	Oil plug	1		C06230C-04-16	03400923181
82	Cover	1		CQ6230C-04-07	03400923182
83	Socket Head Cap Screw	6	M6x25	GB70-85	03400923183
84	Gasket	1		C06230C-04-06	03400923184
85	Spring pin	2	5x30	GB879-86	03400923185
86	Retaining ring	3	12	GB894.1-86	03400923186
87	Changing arm	2		CQ6230-04-15A	03400923187
88	Shifting fork	2		CQ6230-04-12	03400923188
89	Socket head set screw	2	M8x16	GB78-85	03400923189
90	Nut	2	M8	GB6170-86	03400923190
91	Spring pin	2	5x25	GB879-86	03400923191
92	Gear	2		C06230C-04-65	03400923192
93	O-Ring	5	11.2 x 2.65	GB3452.1-82	03400923193
94	Pinion Shaft	2		CQ6230C-04-67	03400923194
95	Key	2		GB1096-79	03400923195
96	Shaft	1		CQ6230C-04-04	03400923196
97	Collar	1		C06230-04-17	03400923197
98	Changing Arm	1		C06230C-04-02	03400923198
99	Shifting Fork	1		CQ6230-04-01	03400923199
100	Shaft	2		CQ6230C-04-14	034009231100
104	Oil Glass	1	A12	GB1 160.1-74	034009231104
105	Washer	2	12	GB97.2-85	034009231105
106	Socket head cap screw	2	M12x30	GB70-85	034009231106
107	Cross recessed head screw	6	M3x6	GB818-85	034009231107
108	Plate	1		C06230C-04-11	034009231108
109	Socket head set screw	2	M6x12	GB78 - 85	034009231109
110	Knob	2	BM8x40	GB4141.14-84	034009231110
111	Lever	2		C06230C-04-03A	034009231111
112	Lever handle	2		C06230C-04-05B	034009231112
113	Plate	2		C06230C-04-66	034009231113
114	Steel ball	4	6	GB6308-89	034009231114
115	Compression spring	2	1.2x4.8x27	GB2089-80	034009231115
116	Socket head set screw	4	M8x8	GB77-85	034009231116
117	Spring pin	1	5x40	GB879-86	034009231117
118	Lever	1		C06230C-04-03	034009231118
119	Plate	1		CQ6230C-04-66A	034009231119
120	Compression spring	2	1x5x16	GB2089 - 80	034009231120
121	Lever handle	1		CQ6230C-04-05	034009231121
122	Oil plug	1	ZG 3/8"	Q/ZB285.3	034009231122
123	Socket head set screw	2	M6x10	GB79-86	034009231123
124	Socket head set screw	2	M6x6	GB77-86	034009231124
128	Front cover	1		CQ6230C-04-43 2/2	034009231128
129	Socket head cap screw	4	M6x25	GB70-85	034009231129
130	Pin	2	6x30	GB118-85	034009231130
131	Pad	1			034009231131
132	Plug	1			034009231132
133	Table	1			03400923447
134	O-Ring	1			034009231134
1H6	Power lamp		LA58-XD22		034009231011
1S1	Emergency off				03400923109
1S13	Button direct run				034009231010

## 7.7 Drawing spare parts change gear

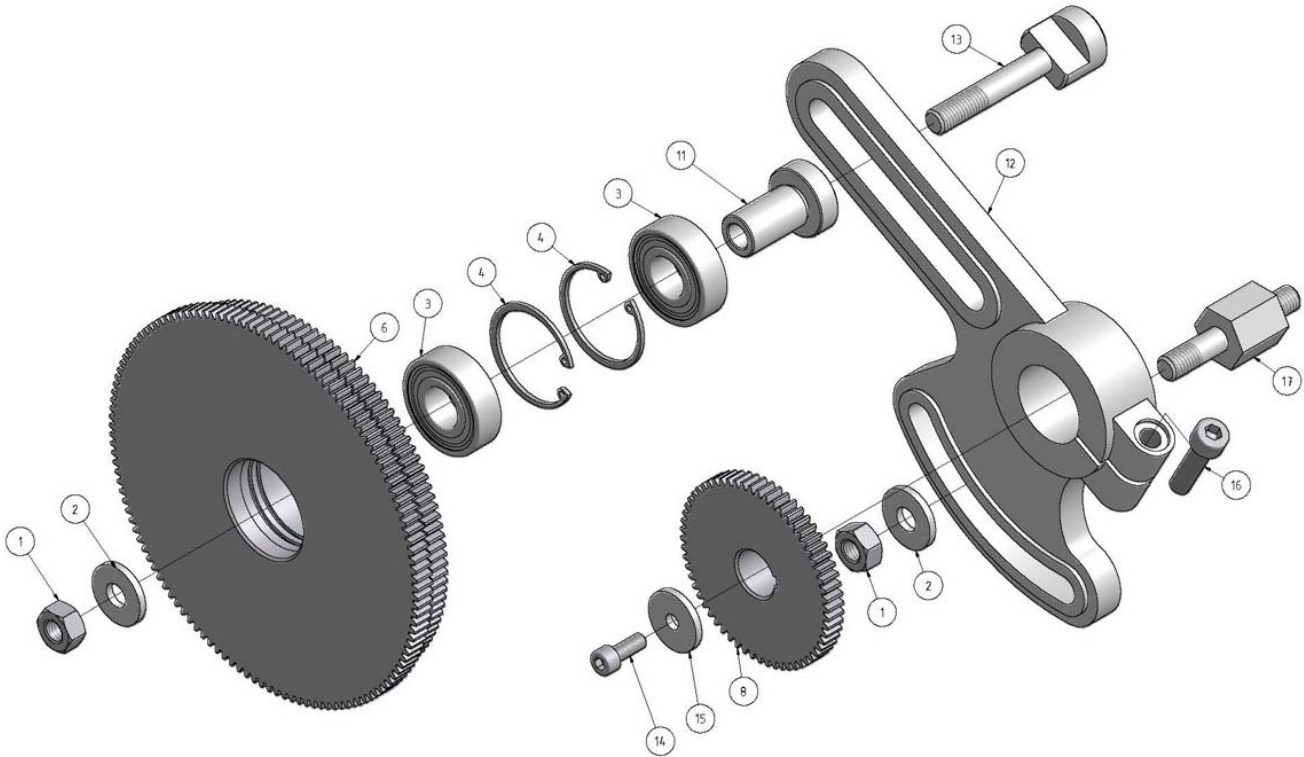

Illustr. 7-7: Change gear

### 7.7.1 Spare parts list change gear

Pos.	Description	Size	Drawing no	Quantity	Article no.
1	Nut	M10	GB6170-86	1	03400923201
2	Sleeve		C0632-01222	1	03400923202
3	Bearing	6203/2RS		2	03400923203
4	Retaining ring	40	GB893.1-87	2	03400923204
5	Retaining ring	55	GB893.1-86	1	03400923205
6	Gear	M1.25 x 120x127	C0632C-01-44	1	03400923206
8	Gear	M1.25 x 60	CL6232-05-41	2	03400923208
11	Sleeve		CM6233-6025	1	03400923211
12	Swing frame		CM6233-6012	1	03400923212
13	Setting bolt		C0632-05228	1	03400923213
14	Socket hand cap screw		M6x15	1	03400923214
15	Washer		CL6132-05-42	1	03400923215
16	Screw	M8x30	GB70-85	1	03400923216
17	Clamping bolt		CM6233-6029	1	03400923217
	Change gear	M1.25x78		1	03400923218
	Change gear	M1.25x69		1	03400923219
	Change gear	M1.25x66		1	03400923220
	Change gear	M1.25x63		1	03400923221
	Change gear	M1.25x57		1	03400923222
	Change gear	M1.25x56		1	03400923223
	Change gear	M1.25x54		1	03400923224
	Change gear	M1.25x30		1	03400923225

## 7.8 Drawing spare parts feed gear 1-6

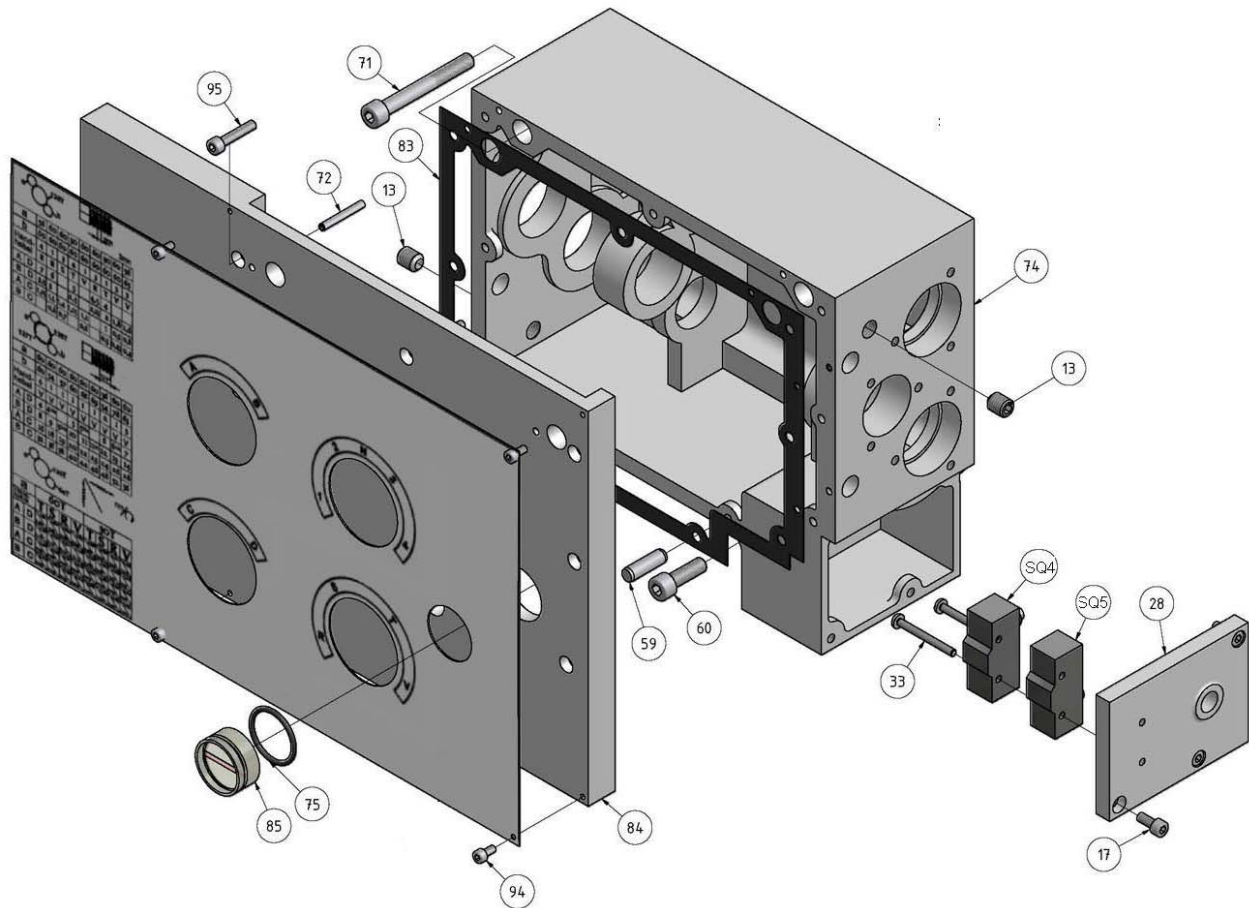

Illustr. 7-8: Feed gear 1-6

7.9 Drawing spare parts feed gear 2-6

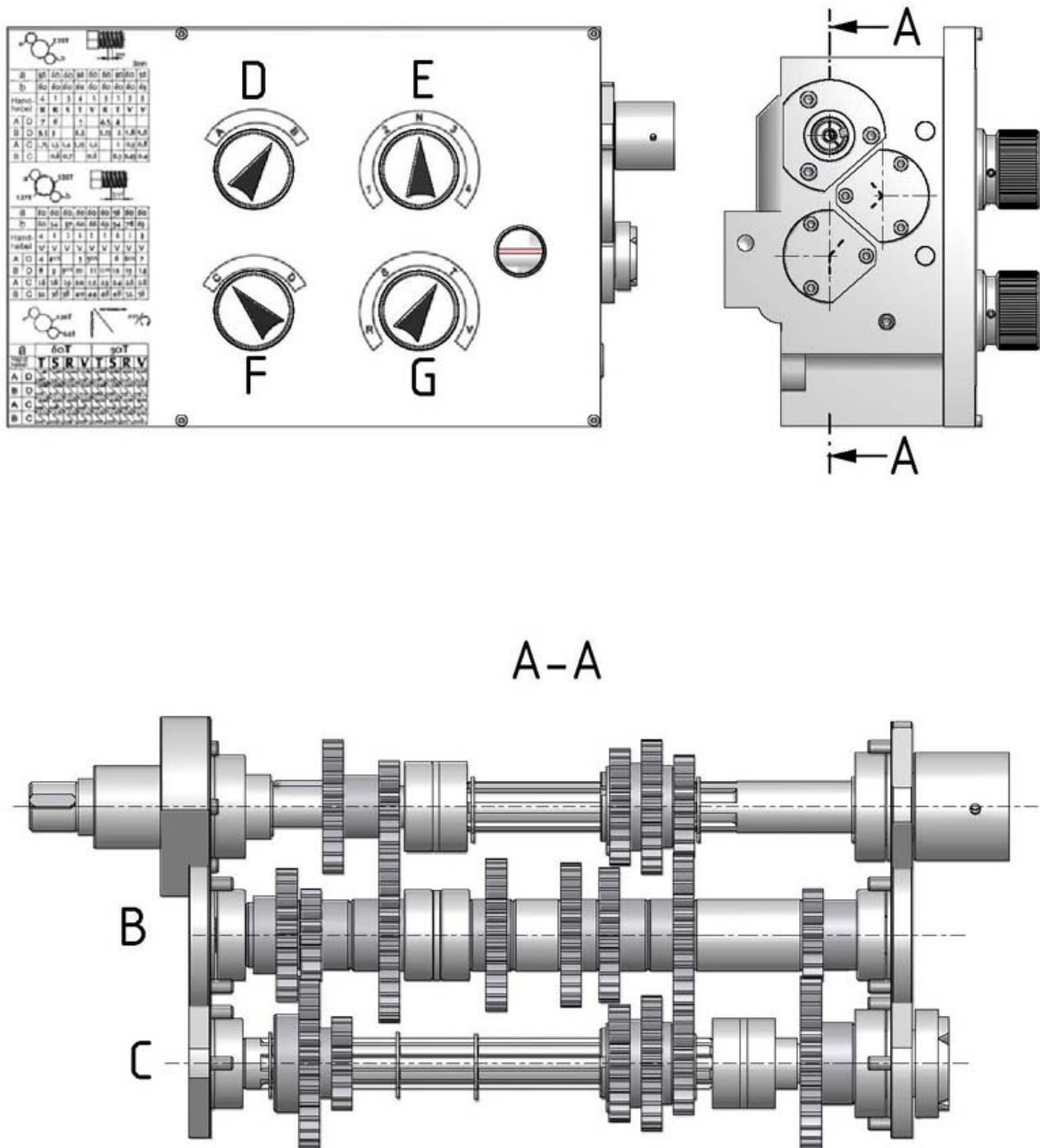

Illustr. 7-9: Feed gear 2-6

## 7.10 Drawing spare parts feed gear 3-6

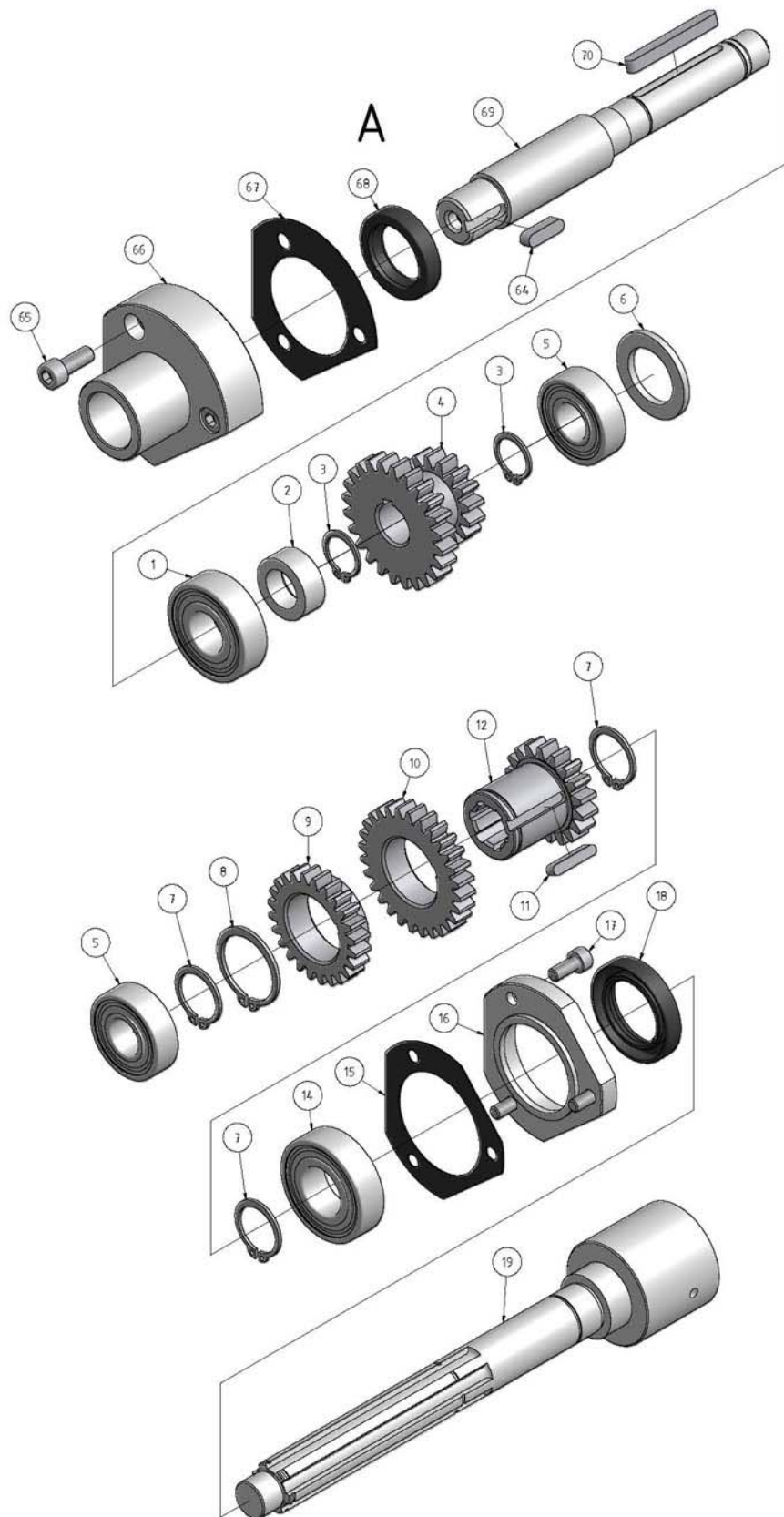

Illustr. 7-10: Feed gear 3-6

7.11 Drawing spare parts feed gear 4-6

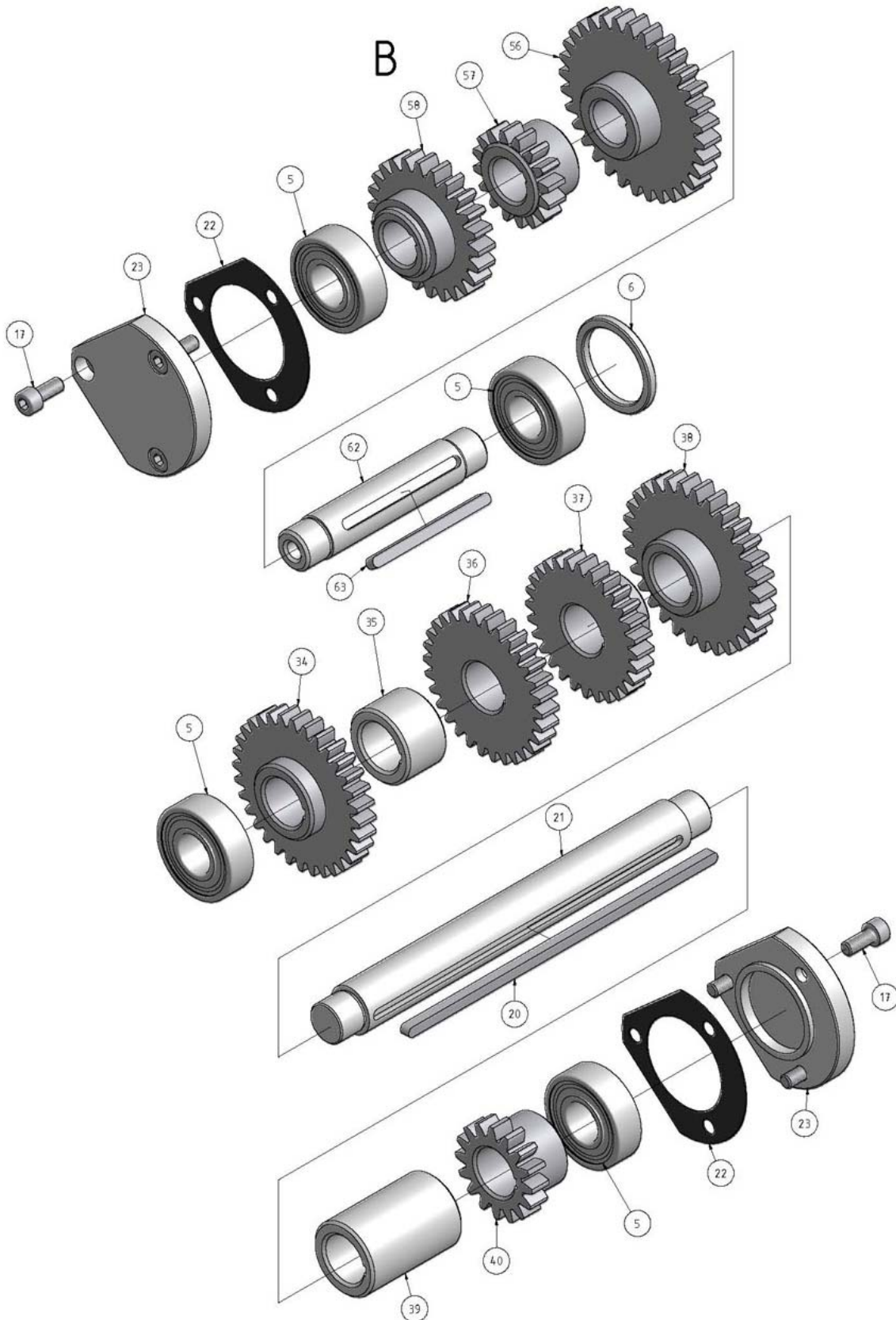

Illustr. 7-11: Feed gear 4-6

## 7.12 Drawing spare parts feed gear 5-6

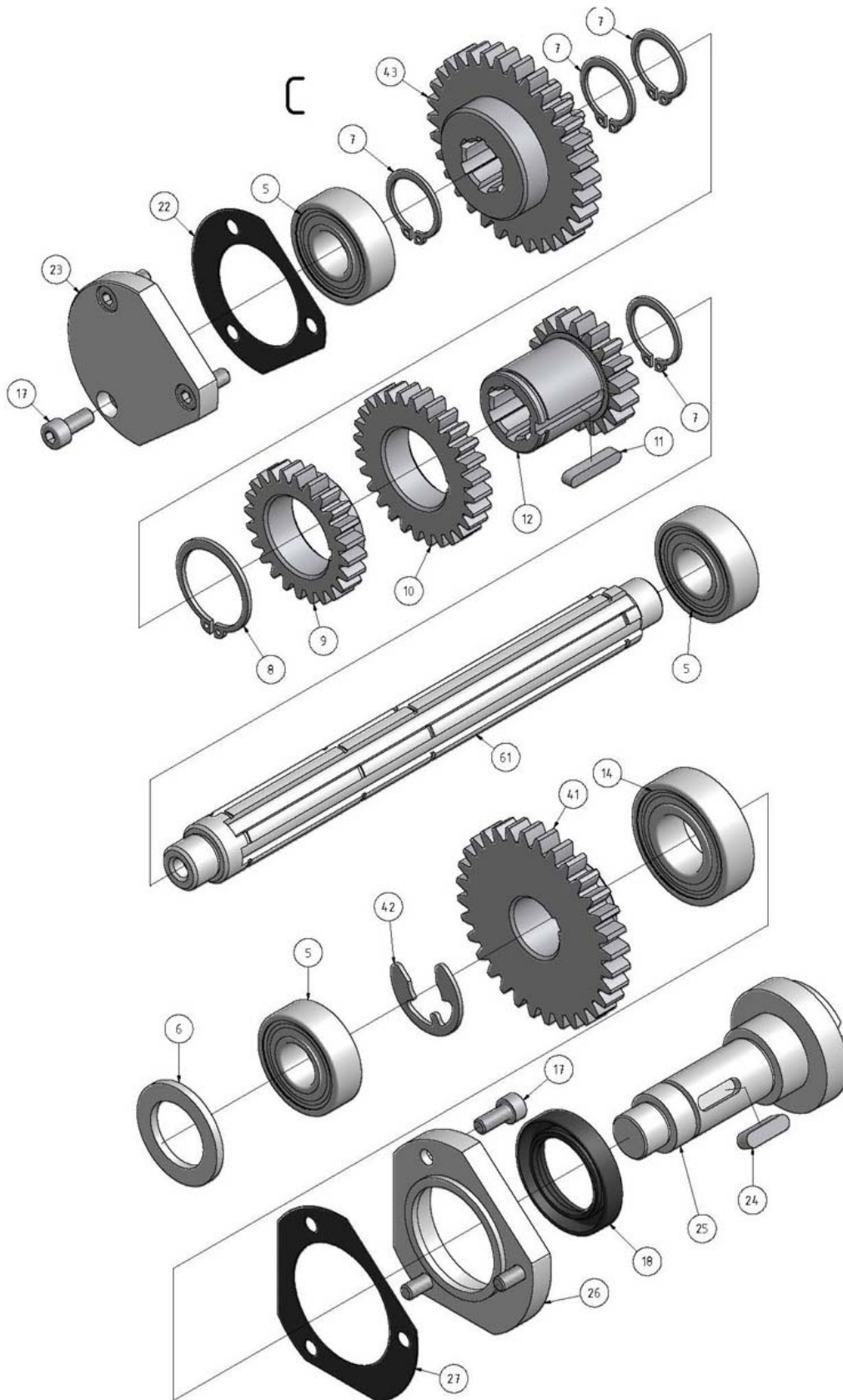

Illustr. 7-12: Feed gear 5-6



7.13 Drawing spare parts feed gear 6-6

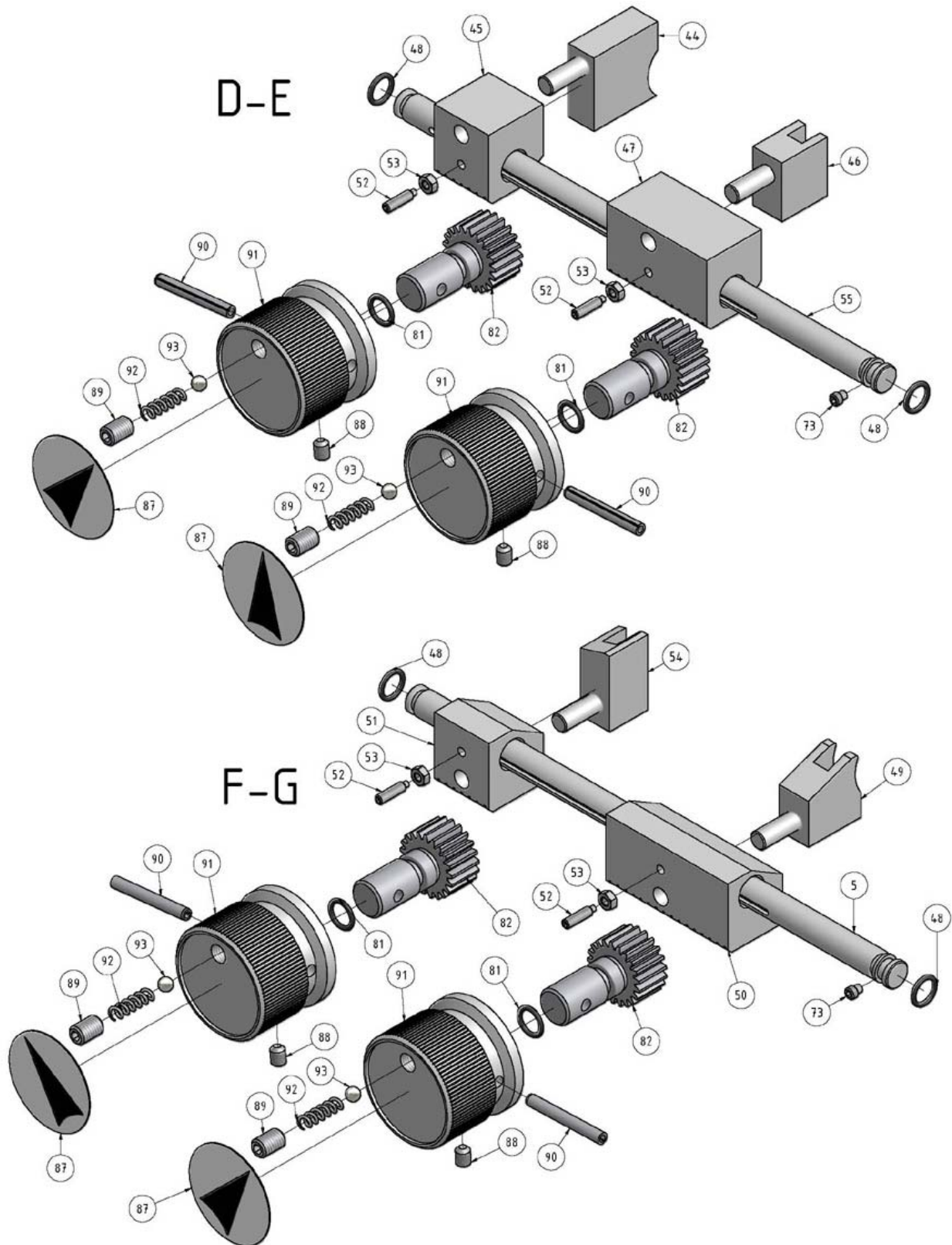

Illustr. 7-13: Feed gear 6-6

### 7.13.1 Spare part list feed gear

Pos.	Description	Quantity	Size	Drawing no	Article no.
1	Deep groove ball bearing	1		GB/T276-94	03400923301
2	Collar	1		CM6233-2029	03400923302
3	Retaining ring	2	Ø 16	GB894.2-86	03400923303
4	Gear	1		CM6233-2003	03400923304
5	Deep groove ball bearing	9	6202-2RS	GB894.2-86	03400923305
6	Spacer	3		CM6233-2004	03400923306
7	Retaining ring	7	Ø 20	GB894.2-86	03400923307
8	Retaining ring	2	Ø 28	GB894.2 86	03400923308
9	Gear	2		CM6233-2006	03400923309
10	Gear	2		CM6233-2007	03400923310
11	Double round head key	2	C4x22	GB1096-86	03400923311
12	Gear	2		CM6233-2008	03400923312
13	Oil Plug	2	ZG 3/8"	Q/ZB285-3	03400923313
14	Deep groove ball bearing	1	6004 - 2RS	GB/T276-86	03400923314
15	Spacer	1		CM6233-2027-1	03400923315
16	Bearing cover	1		CM6233-2027	03400923316
17	Socket head cap screw	18	M5x12	GB70-86	03400923317
18	HG4 - 692 - 67 Oil Seal	2	25x40x7	HG4-692-67	03400923318
19	Shaft	1		CM6220-2005	03400923319
20	Double round head key	1	C4x145	GB1096-86	03400923320
21	Shaft	1		CM6220-2013	03400923321
22	Gasket	1		CM6220-2026-1	03400923322
23	Bearing cover	1		CM6220-2026	03400923323
24	Double round head key	1	5x18	GB1096-86	03400923324
25	Shaft	1		CM6220-2023	03400923325
26	Bearing Cover	1		CM6220-2025	03400923326
27	Spacer	1		CM6220-2025-1	03400923327
28	Switch Cover	1		CM6220-2048	03400923328
33	Button Head Screw	2	M4x45	GB67 - 85	03400923333
34	Gear	1		CM6220-2014	03400923334
35	Spacer	1		CM6220-2015	03400923335
36	Gear	1		CM6220-2016	03400923336
37	Gear	1		CM6220-2017	03400923337
38	Gear	1		CM6220-2018	03400923338
39	Sleeve	1		CM6220-2019	03400923339
40	Gear	1		CM6220-2020	03400923340
41	Gear	1		CM6220-2024	03400923341
42	Retaining ring	1	Ø 15	GB896-86	03400923342
43	Gear	1		CM6220-2022	03400923343
44	Shifting fork	1		CM6220-2040B	03400923344
45	Rack	1		CM6220-2037B	03400923345
46	Shifting fork	1		CM6220-2039B	03400923346
47	Rack	1		CM6220-2035B	03400923347
48	O-Ring	4	Ø12x1.9	GB1235-76	03400923348
49	Shifting fork	1		CM6220-2039C	03400923349
50	Rack	1		CM6220-2036B	03400923350
51	Rack	1		CM6220-2038B	03400923351
52	Counter sunk flat screw	4	M4x16	GB79-85	03400923352
53	Hexagon nut	4	M4	GB6170-86	03400923353
54	Shifting fork	1		CM6220-2040C	03400923354
55	Shaft	2		CM6220-2042	03400923355
56	Gear	1		CM6220-2012	03400923356
57	Gear	1		CM6220-2011	03400923357
58	Gear	1		CM6220 - 20 10	03400923358
59	Taper pin with thread	2	Ø8x26	GB 117-85	03400923359
60	Socket head cap screw	2	M8x25	GB70 - 85	03400923360
61	Shaft	1		CM6220 - 2021	03400923361
62	Shaft	1		CM6220 - 2009	03400923362
63	Double round head key	1	4x55	GB1096-79	03400923363
64	Fitting key	1	5x18	GB1096-79	03400923364
65	Socket head cap screw	1	M6x16	GB70-85	03400923365
66	Bracket	1		CM6220-2028	03400923366
67	Spacer	1		CM6220-2028-1	03400923367

Pos.	Description	Quantity	Size	Drawing no	Article no.
68	Oil seal	1	22x35x7	GB9877.1-88	03400923368
69	Input shaft	1		CM6220-2002	03400923369
70	Double round head key	1	5x5x45	GB1096-79	03400923370
71	Socket head cap screw	2	M8x65	GB70 - 85	03400923371
72	Spring pin	2	Ø 4x30	GB879 - 86	03400923372
73	Grub screw	1	GB78-85/M5x6		
74	Housing	1			03400923374
75	O-Ring	1			03400923375
81	O-Ring	4	P7xW1.9	GB1235-76	03400923381
82	Pinion shaft	4		CM6220-2049-01	03400923382
83	Gasket	1		C06230C-05-02	03400923383
84	Cover	1		CQ6230C-05-01	03400923384
85	Oil sight glass	1	A12	GB 1160.1-89	03400923385
86	Plate	1		C06230C-05-03	03400923386
87	Plate 4	4		CQ6230C-05	03400923387
88	Set screw	4	M6x8	GB80-85	03400923388
89	Set screw	4	M6x10	GB77-85	03400923389
90	Spring pin	4	Ø 5x40	GB879-86	03400923390
91	Knob	4		CM6220-2050	03400923391
92	Spring	4	Ø 1x5x20	GB2089-80	03400923392
93	Steel ball	4	Ø 6	GB308-89	03400923393
94	Cross recessed head screw	4	M4x8	GB818-85	03400923394
95	Screw	8	M5x25	GB70-85	03400923395
1S10	Switch forward	1	220V / 10A	LXW5-11G2 YK06-101 2	034009231014
1S11	Switch backwards	1	220V / 10A	JCH13 VDE 0660 IEC947	034009231015

## 7.14 Drawing spare parts apron 1-3

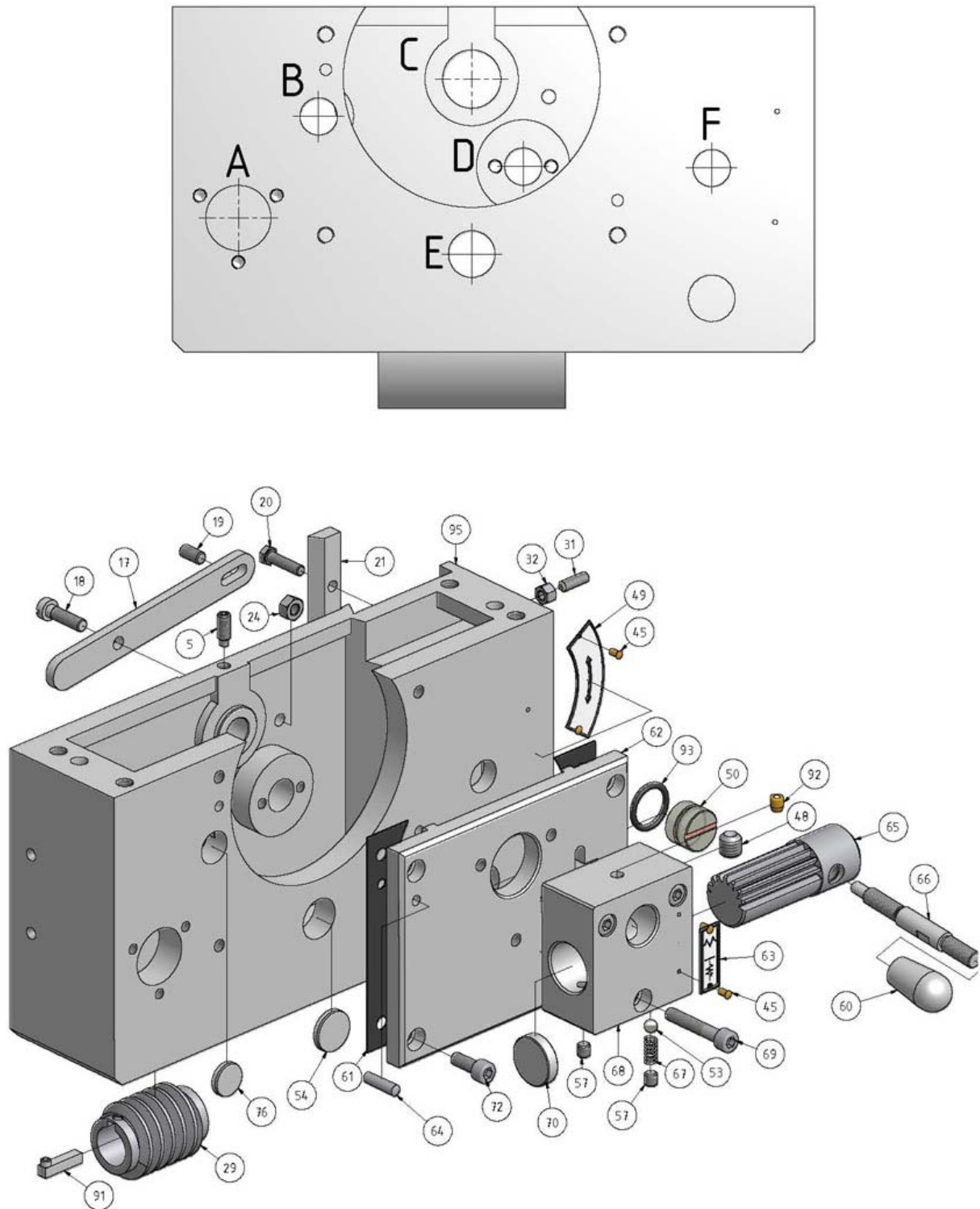

Illustr. 7-14: Apron 1-3

7.15 Drawing spar parts apron 2-3

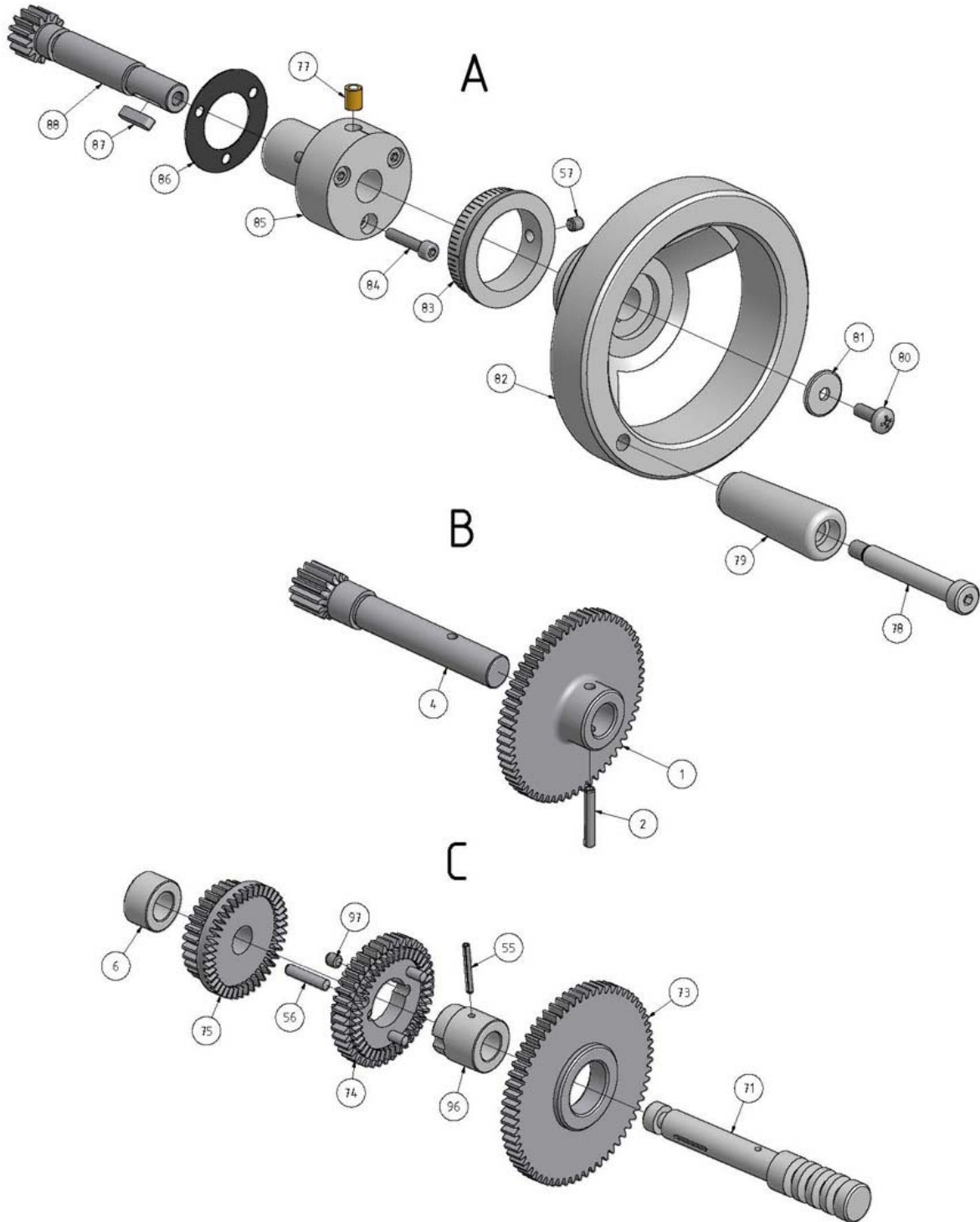

Illustr. 7-15: Apron 2-3

## 7.16 Drawing spare parts apron 3-3

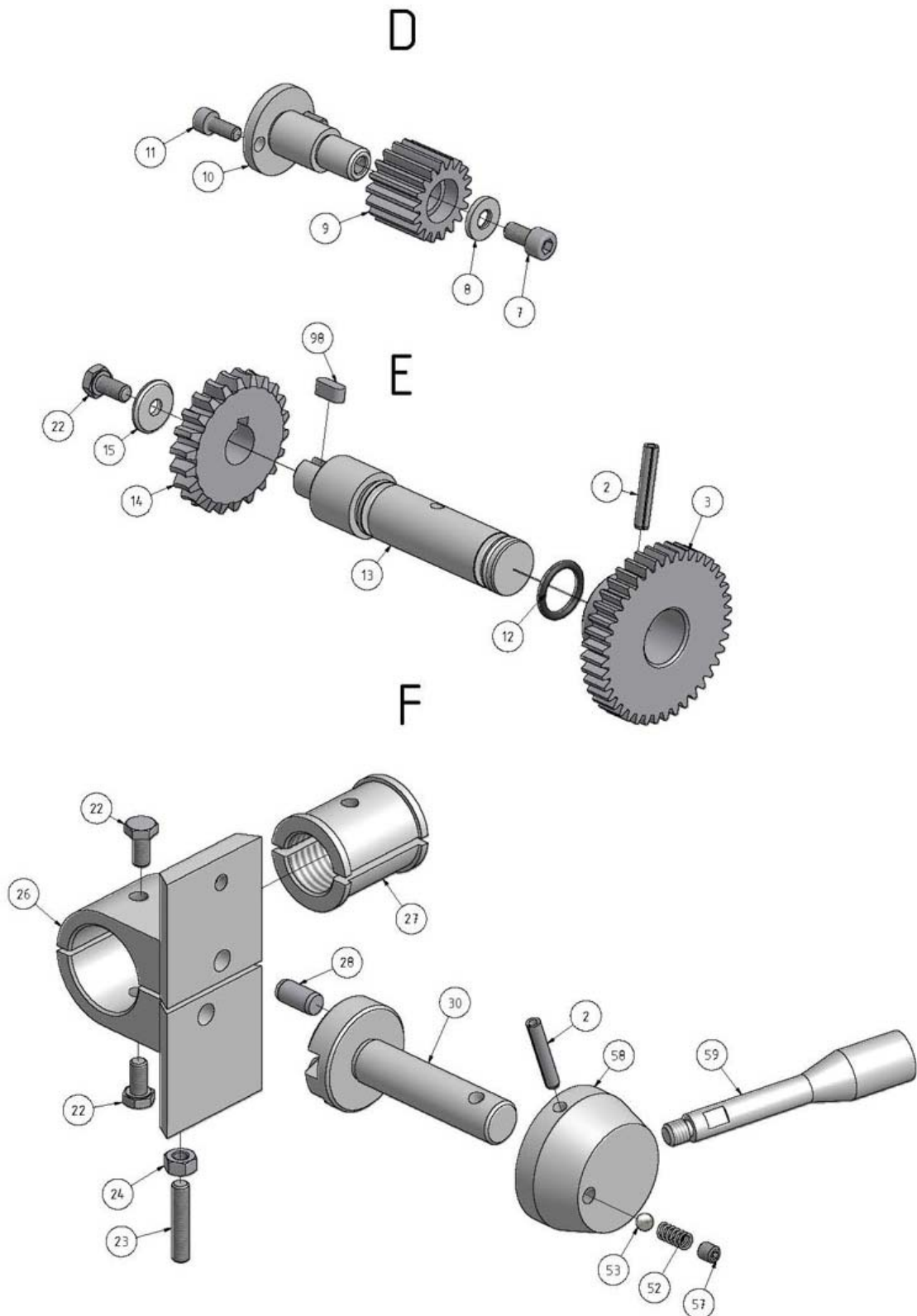

Illustr. 7-16: Apron 3-3

**7.17 Drawing spare parts threading gauge**

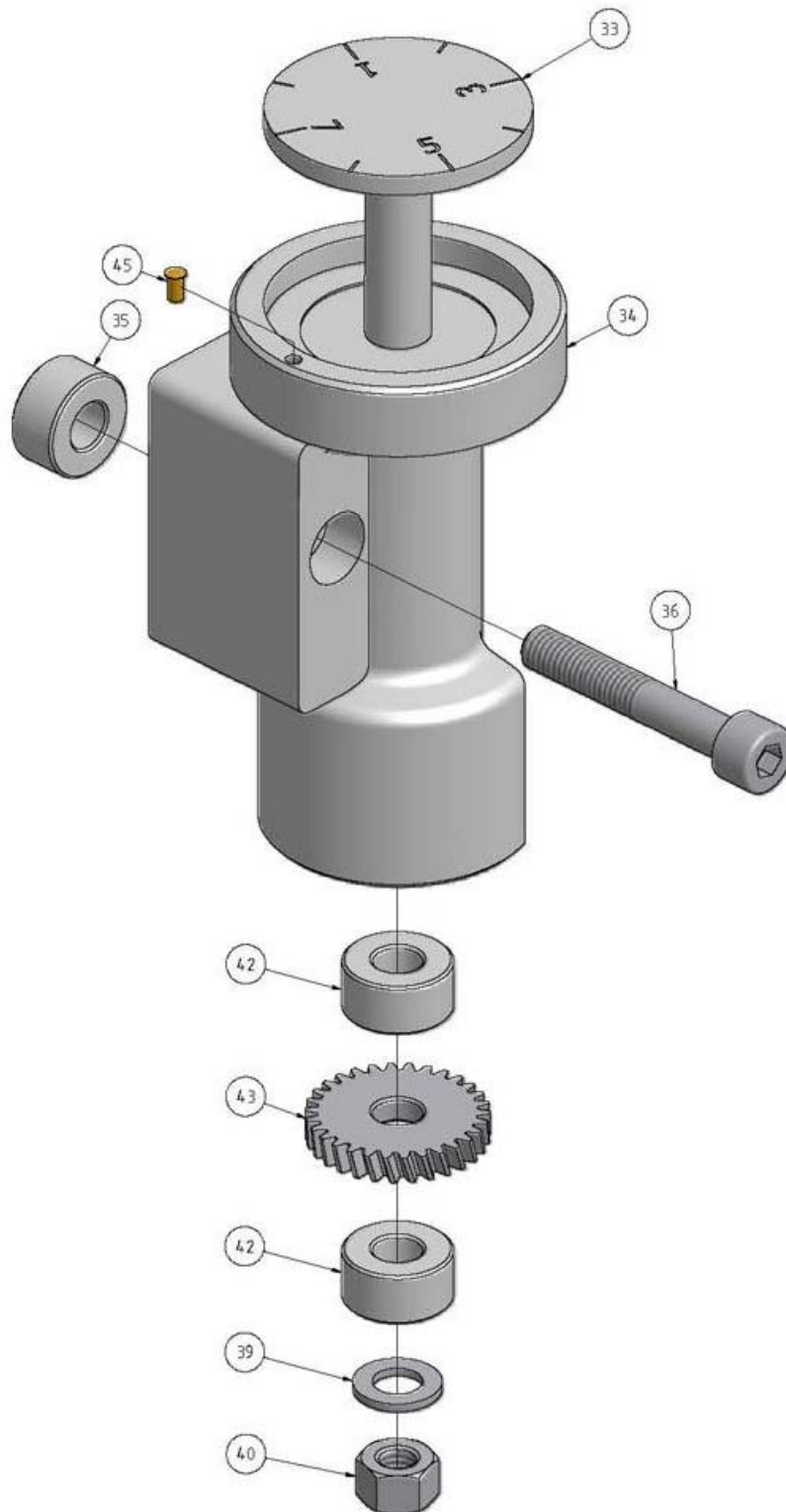

Illustr. 7-17: Threading gauge

## 7.17.1 Spare part list apron

Pos.	Description	Quantity	Size	Drawing no	Article no.
1	Gear	1	M1.5x607	CM6233-4012	03400923401
2	Spring pin	1	5x30	GB879-86	03400923402
3	Gear	1	M1.5x187	CM6233 - 4024	03400923403
4	Pinion shaft	1	M1.5x113	CM6233-4010	03400923404
5	Set screw	1	M6x16	GB79-85	03400923405
6	Sleeve	1		CM6233-4049	03400923406
7	Socket head cap screw	1	M6x12	GB70 - 85	03400923407
8	Washer	1		C0632-06240	03400923408
9	Gear	1		C0632-06231	03400923409
10	Idle shaft	1		C0632-06232	03400923410
11	Socket head cap screw	1	M5x12	GB70-85	03400923411
12	O-Ring	1		GB1255-77	03400923412
13	Shaft	1		CM6233-4026	03400923413
14	Worm gear	1		C0632-06429	03400923414
15	Washer	1		CM6233-4028	03400923415
16	Cap screw	1	M6x12	GB5783-86	03400923416
17	Interlock piece	1		CM6233-4038	03400923417
18	Pan head screw	1	M6x20	GB6170-86	03400923418
19	Socket head set screw	1	M6x12	GB77-85	03400923419
20	Hexagon head screw	3	M5x20	GB5783-86	03400923420
21	Gib	1		CM6233-4036	03400923421
22	Hexagon head screw	2	M6x10	GB5783-86	03400923422
23	Socket head set screw	1	M6x35	GB77-85	03400923423
24	Hexagon nuts	1	M6	GB6170-85	03400923424
26	Half nut base	1		CM6233-4035	03400923426
27	Half Nut	1			03400928427
28	Pin	2	Ø 8x16	GB119-86	03400923428
29	Worm	1		C0632-06228	03400923429
30	Cam shaft	1		C0632-06225	03400923430
31	Socket head set screw	3	M5x16	GB80-85	03400923431
32	Hexagon nut	3	M5	GB41-86	03400923432
33	Dial Indicator (for metric use)	1		CM6233-4040A	03400923433
33-1	Dial Indicator (for Inch use)	1		CM6233-4040B	03400923425
34	Thread dial body (for metric use)	1		CM6233-4039A	03400923434
37-1	Thread dial body (for Inch use)	1		CM6233-4039B	03400923437
35	Washer	1		C0632-06206	03400923435
36	Socket head cap screw	1	M8x50	GB70-85	03400923436
39	Washer	1	Ø 8	GB95-85	03400923439
40	Hexagon nut	1	M8x50	GB41-86	03400923440
42	Spacer	2			03400928442
43	Gear	1			03400928443
45	Button head river	8	Ø 2x5	GB827-86	03400923445
46	Helical gear chart	1		CM6233-4048	03400923446
47	Indicator table	1		CM6233-4046	03400923447
48	Drain plug	1	1/8"	0/ZG285.3	03400923448
49	Half Nut Indicator	1		CM6233-4050	03400923449
50	Oil sight glass	1	A20	GB 1160-89	03400923450
52	Compression spring	1		CM6233-4001-00-9	03400923452
53	Steel ball	1		GB308-77	03400923453
54	Plug	1		CM6233-4027	03400923454
55	Spring pin	1	Ø 3x25	GB879-86	03400923455
56	Pin	3	C5x25	GB119-85	03400923456
57	Socket head set screw	1	M6x6	GB77-85	03400923457
58	Lever handle	1		CM6233-4033	03400923458
59	Lever	1		CM6233-4034	03400923459
60	Knob	1	M8x40	GB1342-73	03400923460
61	Gasket	1		CM6233-4002-1	03400923461
62	Front cover	1		CM6233-4002	03400923462
63	Feed direction indicator	1		CM6233-4047	03400923463
64	Taper pin	2	5x20	GB 117-86	03400923464
65	Cam shaft	1		CM6233-4020	03400923465
66	Change lever	1		CM6233-4022	03400923466



Pos.	Description	Quantity	Size	Drawing no	Article no.
67	Compression spring	1		CM6233-4019-00-3	03400923467
68	Bracket	1		CM6233-4019	03400923468
69	Socket head cap screw	3	M6x35	GB70-85	03400923469
70	Plug	1		CL6132-06-02	03400923470
71	Shifting shaft	1		CM6233-4013	03400923471
72	Socket head cap screw	4	M6x16	GB70-85	03400923472
73	Clutch gear	1		CQ6230C-06-01	03400923473
74	Clutch gear	1		CM6233-4015	03400923474
75	Clutch gear	1		CM6233-4014	03400923475
76	Plug	1		CM6233-4011	03400923476
77	Lubrication cup	1		GB1155-79	03400923477
78	Bolt	1		CM6233-4008	03400923478
79	Handle	1		CM6233-4009	03400923479
80	Cross recessed head screw	1	M6x15	GB818-85	03400923480
81	Washer	1		CM6233-4007	03400923481
82	Handle wheel	1		CM6233-4005	03400923482
83	Dial	1		CM6233-4006	03400923483
84	Socket head cap screw	3	M5x25	GB70-85	03400923484
85	Bracket	1		CM6233-4004	03400923485
86	Gasket	1		CM6233-4004-1	03400923486
87	Double round head key	1	5x5x20	GB1096-79	03400923487
88	Gear shaft	1		CM6233-4003	03400923488
91	Fitting key	1			03400923491
92	Lubrication cup	1	6		03400923492
93	O-Ring	1			03400923493
95	Housing	1			03400923495
96	Bushing	1			03400923496
97	Grub screw	1	DIN 24766/M6x6		03400923497
98	Fitting key	1	DIN 6885/5x4x12		03400923498

## 7.18 Drawing spare parts lathe compound slide

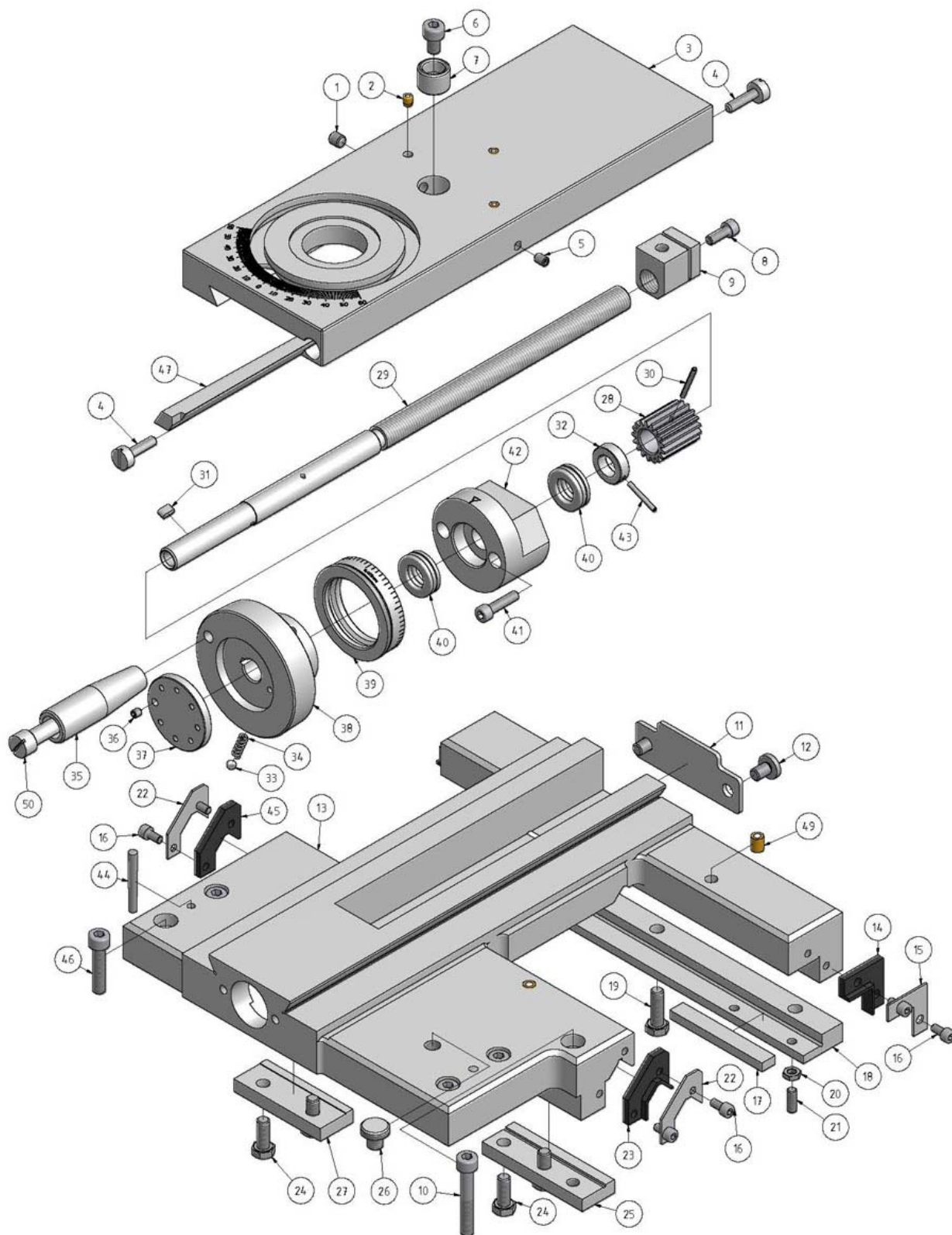

Illustr. 7-18: Compound slide

## 7.18.1 Spare part list compound slide

Pos.	Description	Quantity	Size	Drawing no	Article no.
1	Socket head set screw	1	M8x8	GB77-85	03400923501
2	Ball Cap	5		GB1155-84	03400923502
3	Cross slide	1		CQ6230-07-32a	03400923503
4	Adjust screw	2		CQ6230-07-07	03400923504
5	Socket head set screw	3	M6x8	GB77-85	03400923505
6	Socket head cap screw	1	M8x12	GB70-85	03400923506
7	Setting collar	1		CQ6230-07-34a	03400923507
8	Socket head cap screw	1	M6x18	GB70-85	03400923508
9	Cross feed screw	1			03400928509
10	Setting bolt	1		CQ6230-07-02	03400923510
11	Plate	1		CC0632-07225	03400923511
12	Cross recessed head screw	2	M8x12	GB818-85	03400923512
13	Saddle	1		CQ6230C-07-11a	03400923513
14	Bedway wiper	2		CQ6230-07-12	03400923514
15	Plate	2		C06230-07-12a	03400923515
16	Straight resessed head screw	8	M5x10	GB65-85	03400923516
17	Gib	1		CQ6230-07-04a	03400923517
18	Strip	1		CQ6230-07-01a	03400923518
19	Hexagon head screw	3	M8x25	GB5783-86	03400923519
20	Hexagon nut	4	M6	GB6172-86	03400923520
21	Socket head set screw	4	M6x16	GB78-85	03400923521
22	Plate	2		CQ6230-07-47a	03400923522
23	Bedway wiper	1		CQ6230-07-47	03400923523
24	Hexagon head screw	4	M8x20	GB5783-86	03400923524
25	Strip	1		CQ6230-07-51	03400923525
26	Oil plug	1		CQ6230-07-03	03400923526
27	Strip	1		CQ6230-07-50	03400923527
28	Gear	1		CQ6230C-07-36	03400923528
29	Cross feed screw	1			03400928529
30	Spring pin	1	3x28	GB897-86	03400923530
31	Key 5 x 10 1	1		GB1096-79	03400923531
32	Setting collar	1		CQ6230-07-45	03400923532
33	Steel ball	2	Ø 6	GB308-77	03400923533
34	Compression spring	2	0.7x5x10	GB2089-80	03400923534
35	Handle	1	M8x63	GB4141.5-84	03400923535
36	Socket head set screw	1	M5x16	GB78-85	03400923536
37	Screw	1		C0632-07214C	03400923537
38	Hand wheel	1		CQ6230-07-30C	03400923538
39	Dial	1			03400928539
40	Thrust bearing	2	51102		03400923540
41	Socket head cap screw	2	M6x25	GB70-85	03400923541
42	Bracket	1		CQ6230-07-40	03400923542
43	Spring pin	1	3x25	GB897-86	03400923543
44	Taper pin	2		GB117-86	03400923544
45	Bedway wiper	1		CQ6230-07-10	03400923545
46	Socket head cap screw	4	M8x35	GB70-85	03400923546
47	Gib	1			03400923547
49	Lubrication cup	1	8		03400923549
50	Screw	1			03400923550

## 7.19 Drawing spare parts lathe compound slide

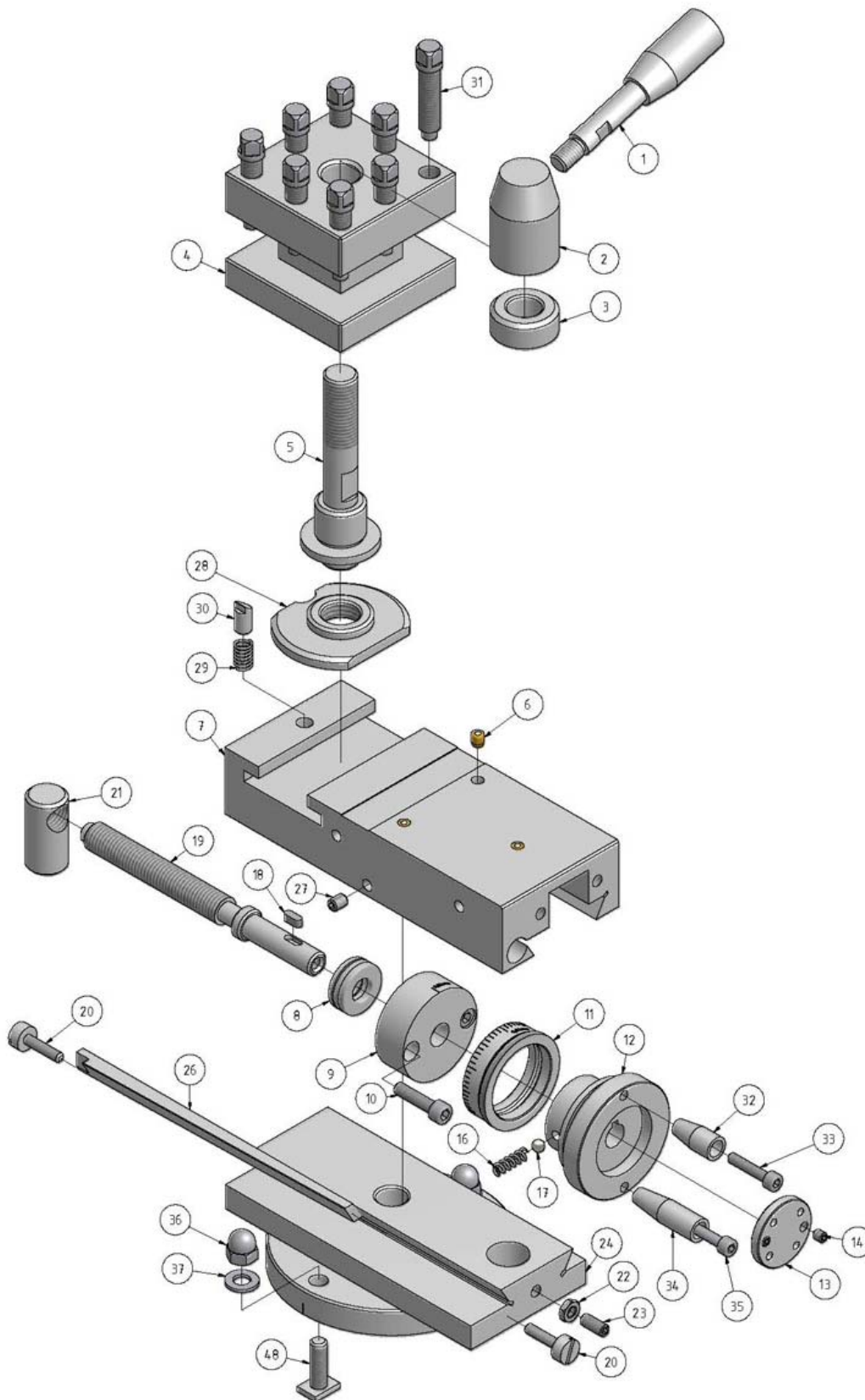

Illustr. 7-19: Compound slide

## 7.19.1 Spare part list compound slide

QTY	Description	Quantity	Size	Drawing no	Article no.
1	Lever	1		C06230-07-21	03400923701
2	Lever handle	1		CQ6230-07-20	03400923702
3	Washer	1		CQ6230-07-19	03400923703
4	Fourway tool post	1		C06230-07-23	03400923704
5	Centering bolt	1		CQ6230-07-18	03400923705
6	Lubrication cup	3		GB1155-84	03400923706
7	compound slide	1		CQ6230-07-24	03400923707
8	Thrust Bearing	2	8101	GB301-84	03400923708
9	Bracket 1	1		CQ6230-07-28C	03400923709
10	Sokket head cap screw	2	M6x25	GB70-85	03400923710
11	Dial	1			03400928711
12	Hand wheel	1		CQ6230-07-43C	03400923712
13	Screw	1		CQ6230-07-43C/ 1	03400923713
14	Socket head set screw	1	M5x6	GB78-85	03400923714
16	Compression spring	2	0.6x3x10	GNB2089-80	03400923716
17	Steel Bail	2	4	GB308-77	03400923717
18	Key	1	4x10	GB1096-77	03400923718
19	Compound feed screw	1			03400928719
20	Adjusting screw	2		CQ6230-07-49	03400923720
21	Compound feed nut	1			03400928721
22	Hexagon nut	1	M6	GB6172-86	03400923722
23	Sokket head set screw	1	M6x15	GB77-85	03400923723
24	Swivel table	1		CQ6230-07-14A	03400923724
26	Taper gib strip	1		CQ6230-07-38	03400923726
27	Sokket head cap screw	1	M6x8	GB77-85	03400923727
28	Bottom plate	1		CQ6230-07-17	03400923728
29	Compression Spring	1	1x5x12	GB2089-80	03400923729
30	Fix position pin	1		CQ6230-07-16	03400923730
31	Tool post screw	8	M10x40	GB83-88	03400923731
32	Sleeve	1			03400923732
33	Screw	1			03400923733
34	Sleeve	1			03400923734
35	Screw	1			03400923735
36	Cap nut	2	DIN1587/M8		03400923736
37	Washer	2	8		03400923737
48	Nut screw	2			03400923584

## 7.20 Drawing spare parts lathe bed 1-2

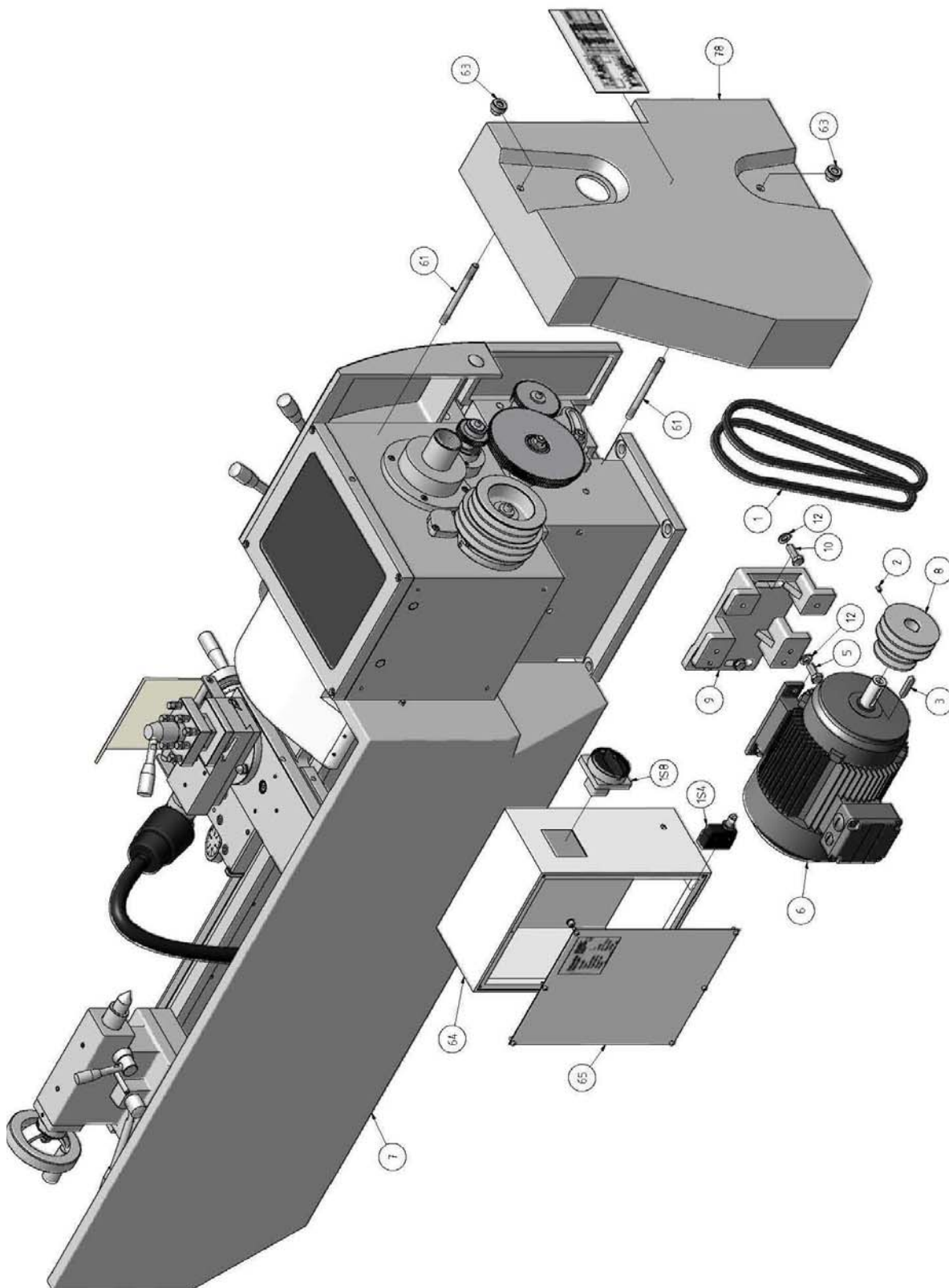

Illustr. 7-20: Lathe bed 1-2

7.21 Drawing spare parts lathe bed 2-2

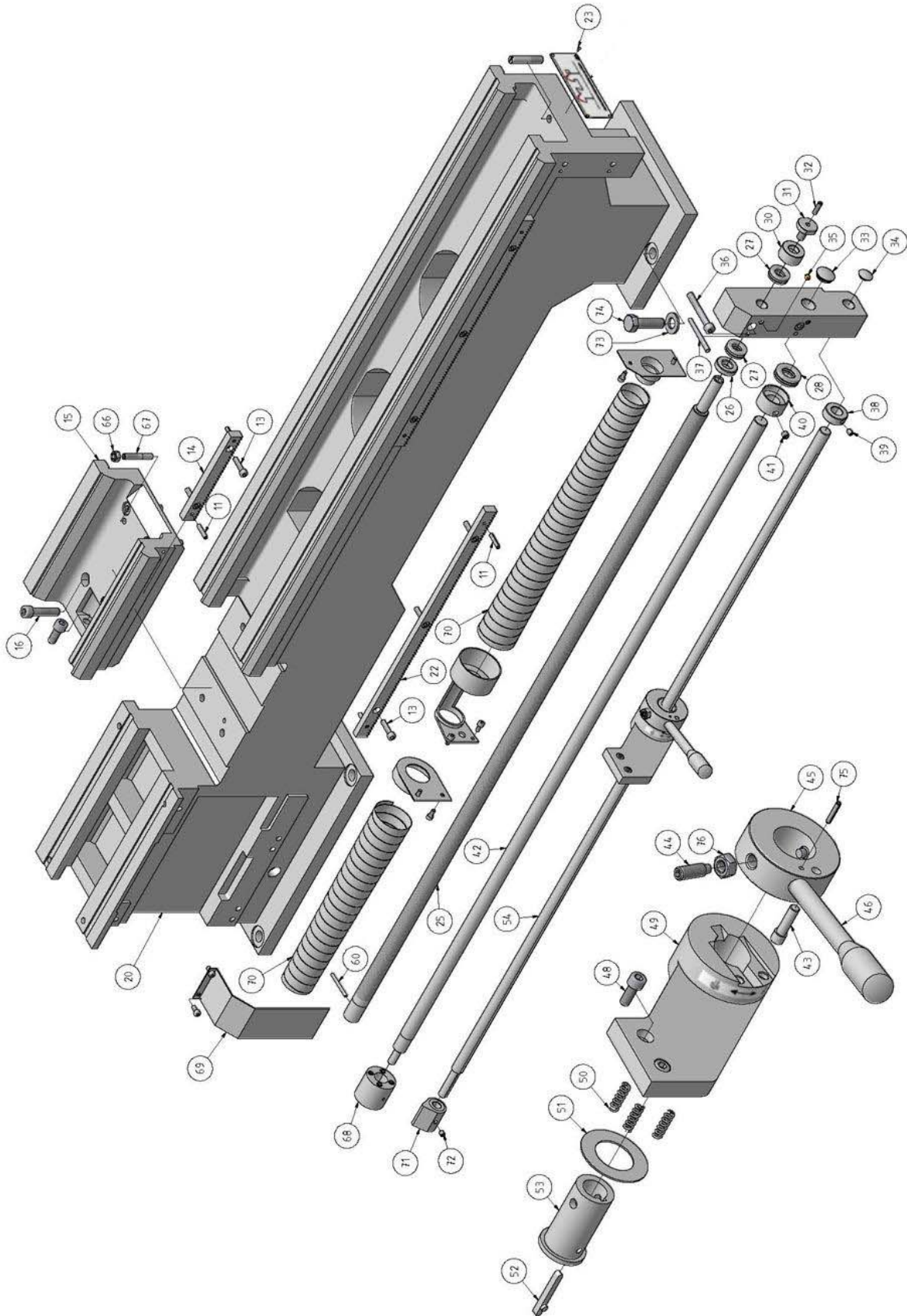

Illustr. 7-21: Lathe bed 2-2

## 7.21.1 Spare part list lathe bed

Pos.	Description	Quantity	Size	Drawing no	Article no.
1	Belt	2	A750	GB1171-74	03400923801
2	Set screw	1	GB77-85/M5x10		03400923802
3	Single round head key	1		GB1096-86	03400923803
5	Hexagon head screw	4	M10x25	GB5783-85	03400923805
6	Motor	1	115/230V		03400928806
7	Splash guard	1	D320x920	CQ6230C-01-25	03400923807
7	Splash guard	1	D320x630		03400633807
8	Pulley	1		CQ6230-01-03	03400923808
9	Bracket	1		CQ6230-01-14	03400923809
10	Hexagon head screw	3	M10x30	GB5783-85	03400923810
11	Spring pin	6	5x25	GB879-85	03400923811
12	Washer	3		GB93-85	03400923812
13	Socket head cap screw	8	M6x25	GB70-85	03400923813
14	Rack	1		C0632-05231	03400923814
15	Gap - Piece	1		C06230-01-07	03400923815
16	Socket head cap screw	4	M10x45	GB70-85	03400923816
20	Lathe bed	1	D320x920	CQ6230C-01-04	03400923820
20	Lathe bed	1	D320x630		03400633820
22	Rack	2	D320x920	CQ6230C-01-19a	03400923822
22	Rack	2	D320x630		03400633822
23	Button head rivet	4	2x5	GB827-86	03400923823
24	Plate	1			03400923824
25	Lead screw	1	D320x920		03400928825
25	Lead screw	1	D320x630		03400633825
26	Sleeve	1		0M6233-6037	03400923826
27	Bearing	2	51102		03400923827
28	Bearing	1	51104		03400923828
29	Bracket	1		CM6233-6035	03400923829
30	Bearing Cover	1		CM6233-6038	03400923830
31	Lock screw	1		CM6233-6039	03400923831
32	Socket head set screw	1	M6x20	GB78-85	03400923832
33	Plug	1		C0632-01503	03400923833
34	Plug	1		C0632-01504	03400923834
35	Ball cap	2	6	GB1155-79	03400923835
36	Socket head cap screw	2	M8x60	GB70-85	03400923836
37	Taper pin	2	5x60	GB117-86	03400923837
38	Sleeve	1		CM6233-6053	03400923838
39	Socket head set screw	1	M6x8	GB77-85	03400923839
40	Bearing cover	1		CL6132-01-16	03400923840
41	Name Socket head set screw	1	M6x10	GB77-85	03400923841
42	Feed rod	1	D320x920	C06230C-01-06a	03400923842
42	Feed rod	1	D320x630		03400633842
43	Position setting pin	1		CM6233-6049	03400923843
44	Socket head set screw	1	M8x16	GB79-85	03400923844
45	Gated Block	1		CM6233 - 6048	03400923845
46	Spindle control lever	1		CM6233-6050	03400923846
48	Socket head cap screw	2	GB70-85/M6x16		03400923848
49	Bracket	1		CM6233-6045	03400923849
50	Compression spring	1	1x6x20	GB2089-80	03400923850
51	Thrust Piece	1		RUN6246-106058	03400923851
52	Key	1		C0632-01213	03400923852
53	Sleeve	1		C0632-01201	03400923853
54	Started rod	1	D320x920	CQ6230C-01-05	03400923854
54	Started rod	1	D320x630		03400633854
60	Shear pin	1		CM6220-2085	03400923860
61	Bolt	1		C06230-01-02	03400923861
62	Hexagon nut	1	M10	GB6170-86	03400923862
63	Nut	1		CQ6230-01-01	03400923863
64	Electrical box	1			03400923864
65	Cover	1			03400923865
66	Hexagon nut	2	ISO 4032/M8		
67	Grub screw	2			



<b>Pos.</b>	<b>Description</b>	<b>Quantity</b>	<b>Size</b>	<b>Drawing no</b>	<b>Article no.</b>
68	Friction clutch cpl.	1			03400923857CPL
69	Cover	1			03400923869
70	Lead screw cover cpl.	1			0343102
71	Eccentric	1			03400923329
72	Grub screw	1	GB80-86/M6x8		
73	Washer	6	15		
74	Hexagon nut	6	ISO4017/M14x45		
75	Spring pin	1	DIN8752/3x16		
76	Hexagon screw	2	ISO4032/M8		
77	Table	1			03400923877
78	Protective cover	1			03400923878
1S4	Position switch protection head stock cover	1	LXW5-11Q1		034009231013

## 7.22 Drawing spare parts machine substructure

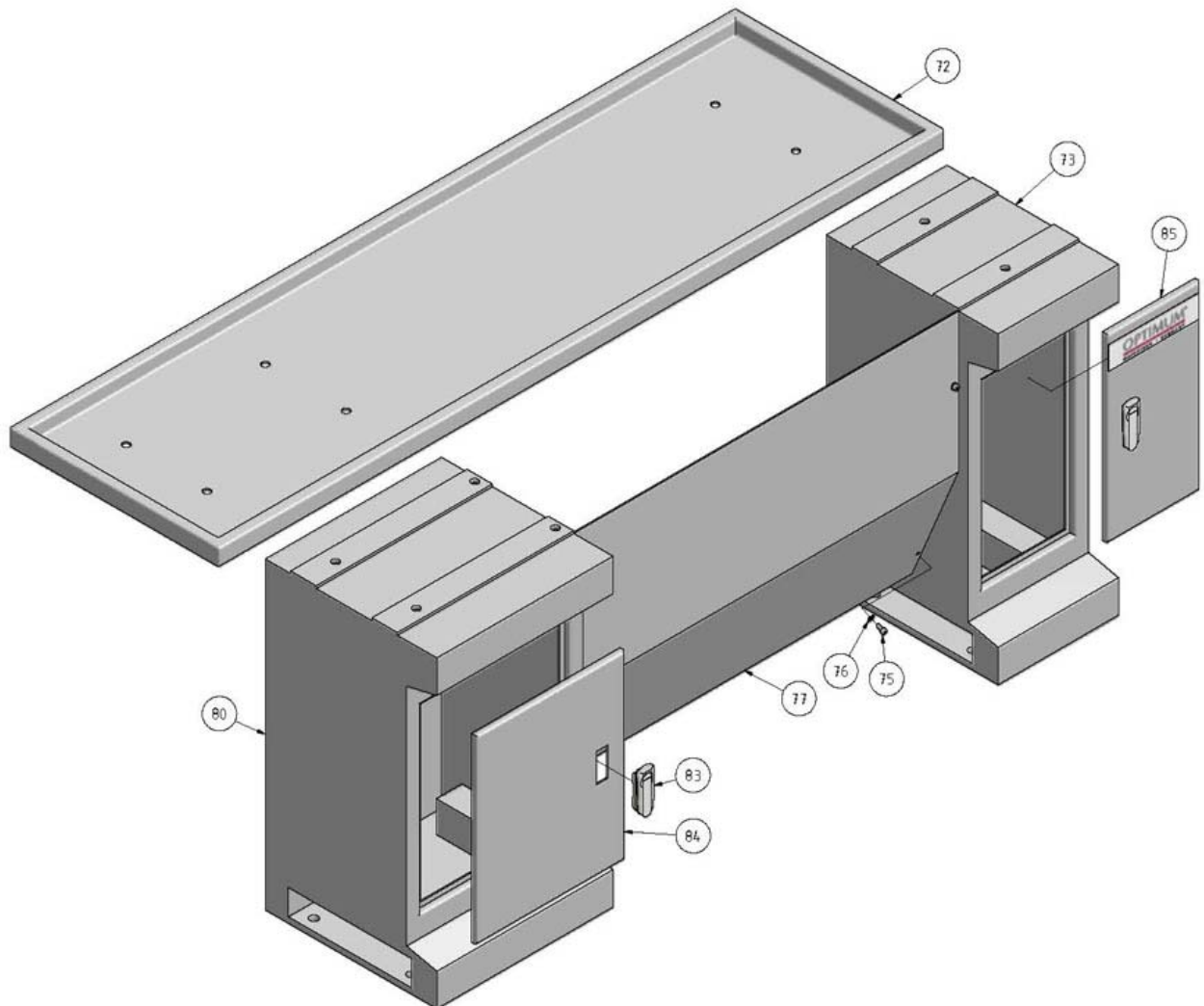

### 7.22.1 Spare part list machine substructure

Lathe bed add-on pieces					
Pos.	Description	Quantity	Size	Drawing no	Article no.
72	Chip Pan	1	D320x920	CQ6230C-01-23	03400923821
72	Chip Pan	1	D320x630		03400633821
73	Right stand end	1		CQ6230C-01-27 3/3	03400923873
75	Cross recessed head screw	8	M5x8	GB95-85	03400923875
76	Washer	8	5	C06230C-01-27 2/3	03400923876
77	Front plate	1	D320x920	C06230C-01-27 1/3	03400923877
77	Front plate	1	D320x630		03400633877
80	Left stand end	1		GB95-85	03400923880
83	Door lock	2			03400923883
84	Door right	1			03400923884
85	Door left	1			03400923885

**7.23 Drawing spare parts tailstock**

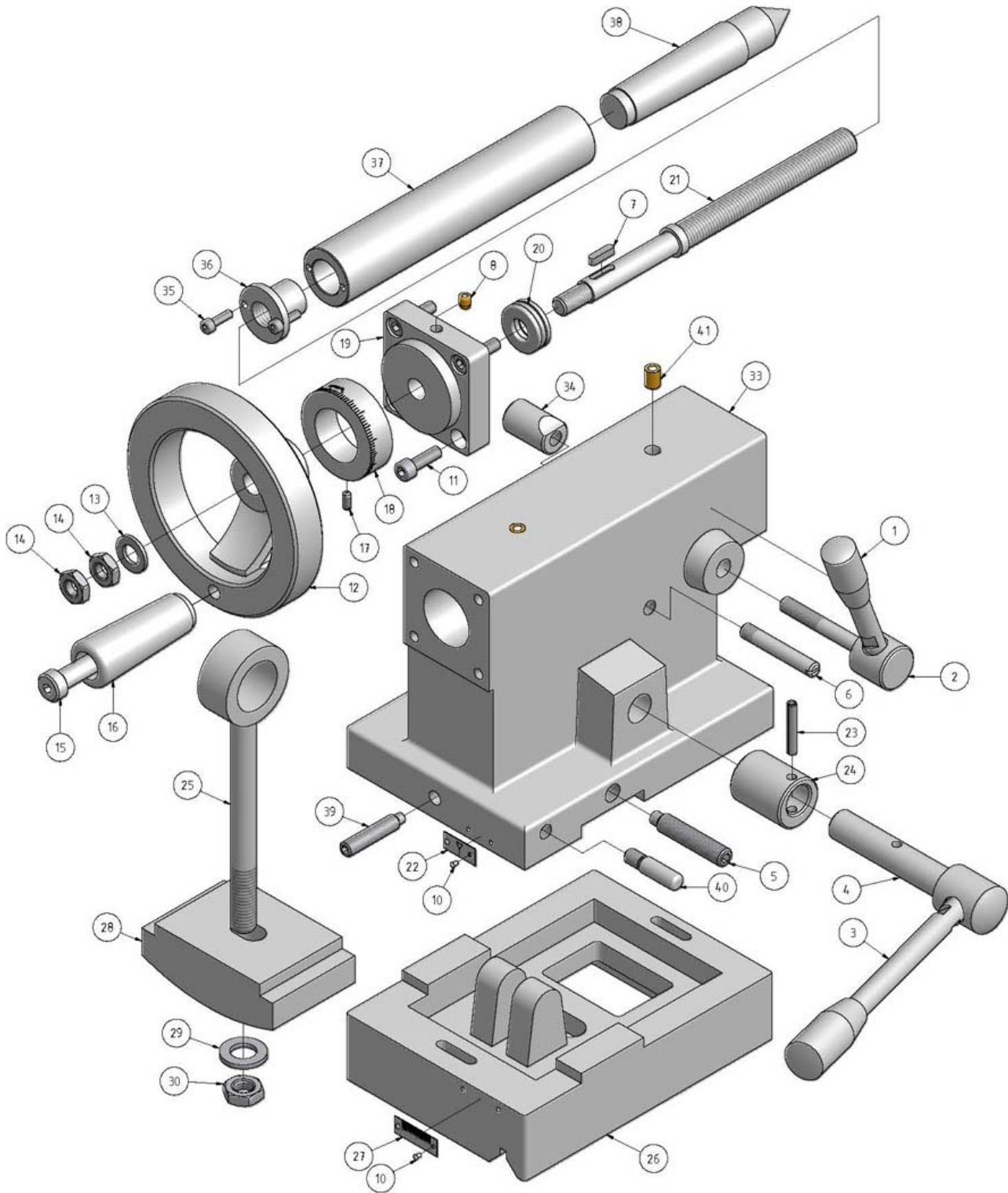

Illustr. 7-22: Tailstock

## 7.23.1 Spare part list tailstock

Pos.	Description	Quantity	Size	Drawing no	Article no.
1	Handle	1	034009239	C06230-08-17a	03400923901
2	Locking rod	1		C06230-08-16	03400923902
3	Handle	1		C06230-08-09a	03400923903
4	Clamping shaft	1		C06230-08-08	03400923904
5	Socket head set screw	2	M10x50	GB79-85	03400923905
6	Screw	1		C06230-08-19	03400923906
7	Key	1	4x14	GB1096-79	03400923907
8	Lubrication cup	3	6		03400923908
10	Button head rivet	4	5x5	GB827-86	03400923910
11	Socket head rivet	4	M6x20	GB70-85	03400923911
12	Hand Wheel	1		CQ6230-08-06	03400923912
13	Washer 10	1		GB95-85	03400923913
14	Hexagon nut	2	M10	GB6172-86	03400923914
15	Bolt	1		C0632-07207b 1/2	03400923915
16	Handle	1		C0632-07207b 2/2	03400923916
17	Straight recessed head screw	1	M4x10	GB74-85	03400923917
18	Dial	1			03400928918
19	Bracket	1		CQ6230-04-04	03400923919
20	Thrust bearing	1	51101		03400923920
21	Feed screw	1			03400928921
22	Set-over indicating chart	1		C0632-08405	03400923922
23	Spring pin	1	5x30	GB879-86	03400923923
24	Eccentric collar	1		CQ6230-08-10	03400923924
25	Bolt	1		CQ6230-08-14	03400923925
26	Tailstock base	1		CQ6230-08-12	03400923926
27	Set-over indicating chart	1		C0632-08404	03400923927
28	Setting block	1		CQ6230-08-13	03400923928
29	Washer	1		GB95-85	03400923929
30	Hexagon nut	1	M12	GB6172-86	03400923930
31	Hexagon nut	1	M8	GB6172-86	03400923931
32	Socket head set screw	1	M8x30	GB79-85	03400923932
33	Tailstock casting	1		CQ6230-08-11	03400923933
34	Locking bush	1		CQ6230-08-18	03400923934
35	Socket head cap screw	3	M4x10	GB70-85	03400923935
36	Feed nut	1			03400928936
37	Sleeve	1		CQ6320-08-01a	03400923937
38	Steady centers	1			03400923938
39	Grub screw	1			03400923939
40	Bolt	1			03400923940
41	Lubrication cup	1	8		03400923941

7.24 Drawing spare parts steady rest

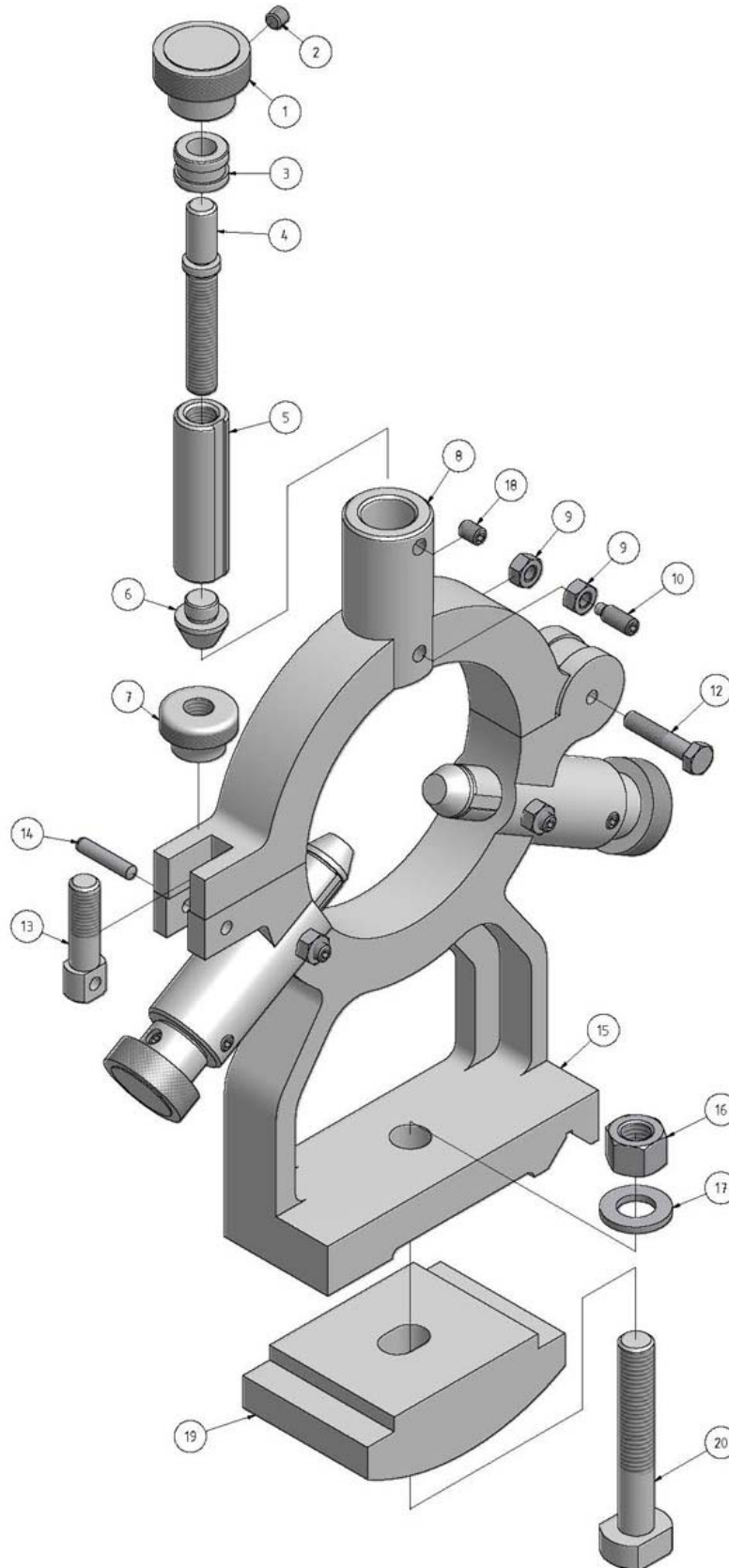

Illustr. 7-23: Steady rest

## 7.24.1 Spare part list steady rest

Pos.	Description	Quantity	Drawing no	Article no.
1	Knurled handle	3		034009231001
2	Grub screw	3	GB 78-85 - M6 x 6	034009231002
3	Nut	3		034009231003
4	Threaded rod	3		034009231004
5	Centering bushing	3		034009231005
6	End piece	3		034009231006
7	Nut	1		034009231007
8	Steady rest upper section	1		034009231008
9	Hexagon nut	4	GB 6170-86 - M6	034009231009
10	Grub screw	3	GB 79-85 - M6 x 16	0340092310010
12	Screw	1	GB 5782-86 - M6x30	0340092310012
13	Threaded bolt	1		0340092310013
14	Straight pin	1	GB 119-86 - A 5 x 24	0340092310014
15	Follow rest lower part	1		0340092310015
16	Hexagon nut	1	GB 41-86 - M 12	0340092310016
17	Washer	1	DIN 125 - A 13	0340092310017
18	Grub screw	3	GB 78-85 - M6 x 8	0340092310018
19	Clamping plate	1		0340092310019
20	Clamping screw	1		0340092310020
	Steady rest complete			0340092310015CPL

## 7.25 Drawing spare parts movable rest

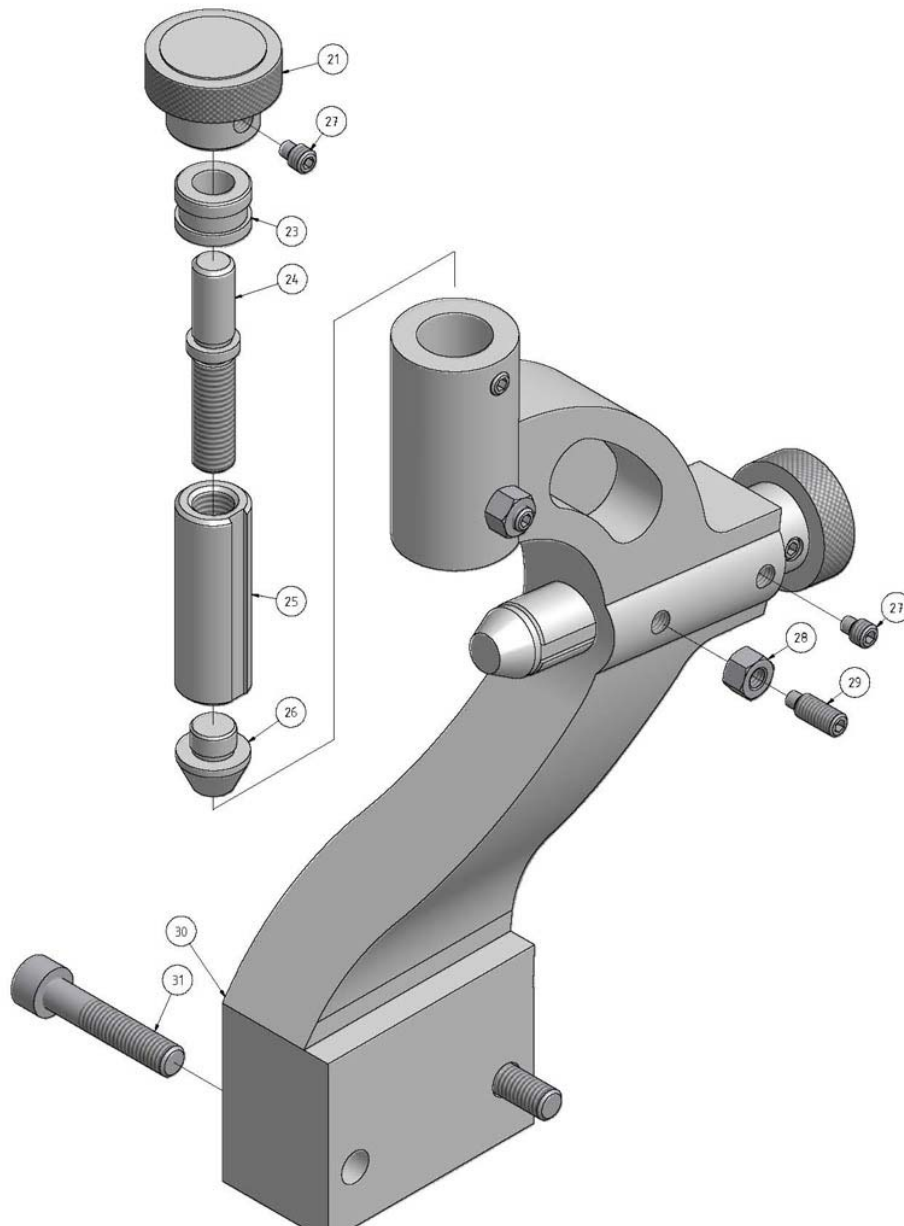

Illustr. 7-24: Movable rest

### 7.25.1 Spare part list steady rest

Pos.	Description	Size	Drawing no	Article no.
21	Knurled handle	2		0340092310021
23	Sleeve nut	2		0340092310023
24	Threaded rod	2		0340092310024
25	Centering bushing	2		0340092310025
26	End piece	2		0340092310026
27	Grub screw	4	GB 79-85 - M6 x 8	
28	Hexagon nut	2	GB 41-86 - M 6	
29	Grub screw	2	GB 79-85 - M6 x 16	
30	Body follow rest	1		0340092310030
31	Grub screw	2	GB 70-85 - M8 x 40	
	Follow rest complete			0340092310030CPL

## 7.26 Drawing spare parts chuck protection

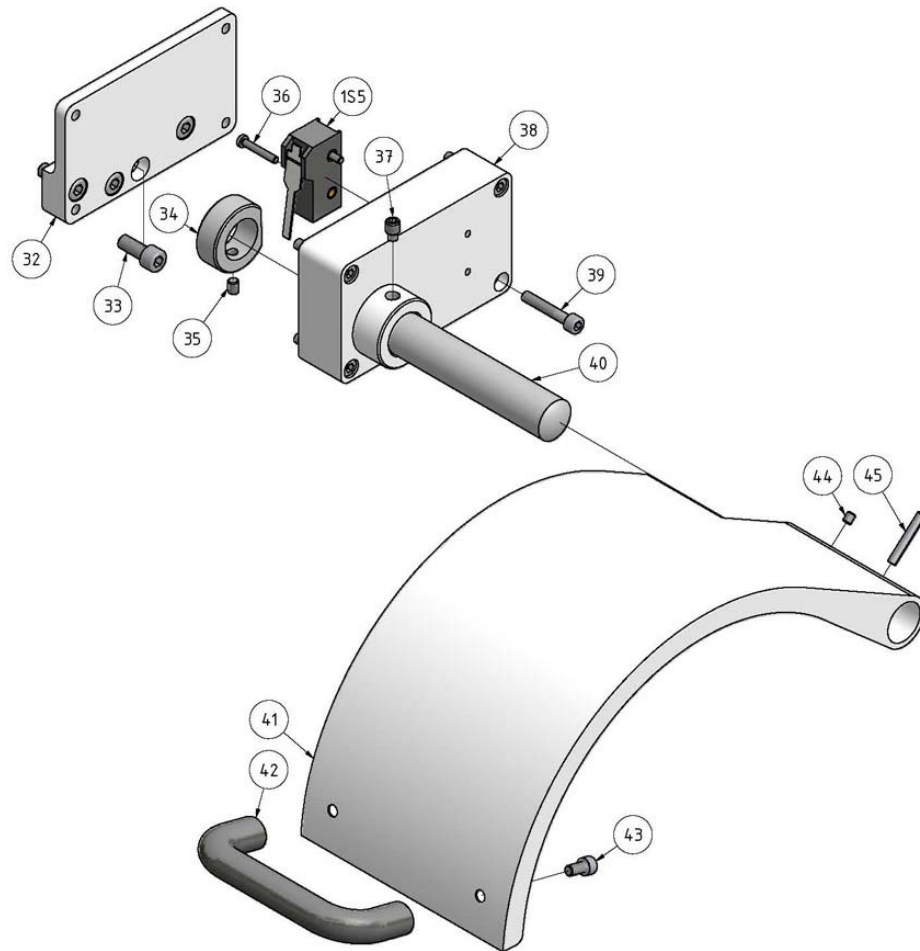

Illustr. 7-25: Chuch protection

### 7.26.1 Spare parts chuck protection

Pos.	Description	Quantity	Drawing no	Article no.
32	Plate	1		0340092310032
33	Socket head screw	4	GB 70-85 - M8 x 20	
34	Eccentric	1		0340092310034
35	Grub screw	1	GB 78-85 - M6 x 8	
36	Screw	2	GB 823-88 - M4 x 25	
37	Grub screw	1	GB 79-85 - M8 x 12	
38	Cover	1		0340092310038
39	Socket head screw	4	GB 70-85 - M6 x 35	
40	Shaft	1		0340092310040
41	Protection cover	1		0340092310041
42	Handle	1		0340092310042
43	Socket head screw	2	GB 70-85 - M6 x 12	
44	Grub screw	1	GB 78-85 - M5 x 6	
45	Spring pin	1	GB 879-86 - 5 x 32	
1S5	Position switch protection jaw chuck	1	LXW5-11Q1	034009231012
	Chuck protection cpl.			0340092310041CPL



**7.27 Drawing spare parts chip protection**

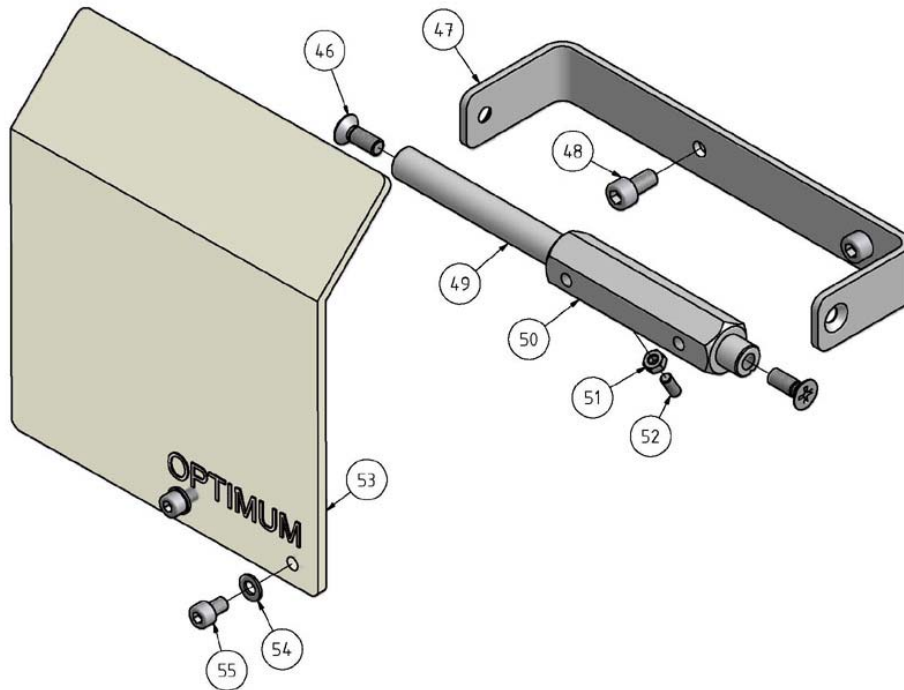

Illustr. 7-26: Chip protection

**7.28 Drawing spare parts chip protection D320 DPA**

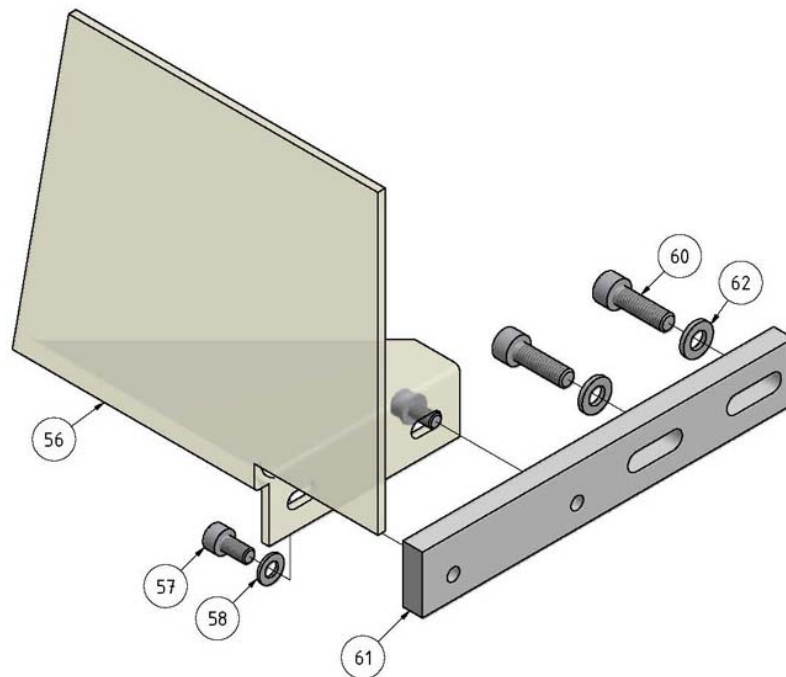

Illustr. 7-27: Chip protection DPA

## 7.28.1 Spare parts chip protection

Pos.	Description	Quantity	Size	Article no.
46	Screw	2	GB 819-85 - M6x16	
47	Holder	1		0340092310047
48	Socket head screw	2	GB 70-85 - M6 x 12	
49	Shaft	1		0340092310049
50	Hexagon bushing	1		0340092310050
51	Hexagon nut	1	GB 6170-86 - M4	
52	Grub screw	1	GB 78-85 - M4 x 10	
53	Protection cover	1		0340092310053
54	Washer	2	DIN 125 - A 5,3	
55	Socket head screw	2	GB 70-85 - M5 x 8	
	Chip protection cpl.			0340092310053CPL
56	Protection cover	1		0340092310056
57	Socket head screw	2	GB 70-85 - M5 x 10	
58	Washer	2	DIN 125 - A 5,3	
60	Holder	2		0340092310060
61	Socket head screw	2	GB 70-85 - M6 x 20	
62	Washer	1	DIN 125 - A 6,4	
	Chip protection DPA cpl.			0340092310056CPL

**7.29 Drawing spare parts machine lamp**



Illustr. 7-28: Machine lamp

**7.29.1 Spare parts machine lamp**

Pos.	Description	Quantity	Size	Article no.
63	Spring ring	1		0340092310063
64	Glas plate	1		0340092310064
65	Lamp	1		0340092310065
66	Reflector	1		0340092310066
67	Housing	1		0340092310067
68	Guide	1		0340092310068
69	Socket head screw	3	GB 70-85 - M5 x 20	
70	Collet	1		0340092310070
71	Socket head screw	2	GB 70-85 - M6 x 20	
72	Ground plate	1		0340092310072
	Machine lamp cpl.			0340092310066CPL

## 7.30 Spare parts drawing D320x920, D320x920 DPA, DPA2000, measuring gib

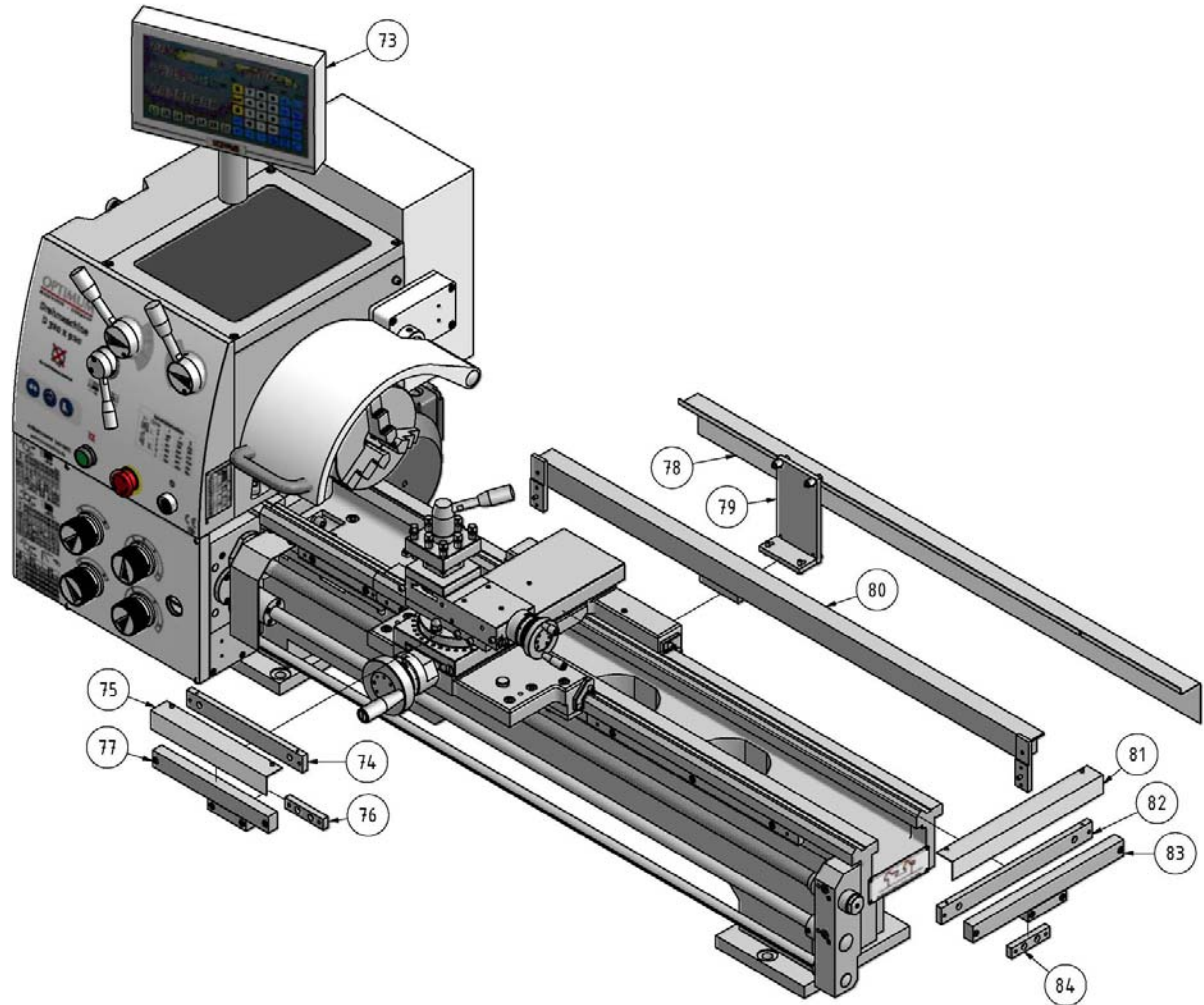

Illustr. 7-29: DPA2000, measuring gib

### 7.30.1 Spare parts DPA2000, measuring gib

Pos	Description	Quantity	Article no.
73	DPA2000	1	0340092310073
74	Plate	1	0340092310074
75	Cover	1	0340092310075
76	Plate	1	0340092310076
77	Measuring gib compound slide	1	0340092310077
78	Cover	1	0340092310078
79	Holder	1	0340092310079
80	Measuring gib lathe slide	1	0340092310080
81	Cover	1	0340092310081
82	Plate	1	0340092310082
83	Measuring gib cross slide	1	0340092310083
84	Plate	1	0340092310084

7.31 Wiring diagram

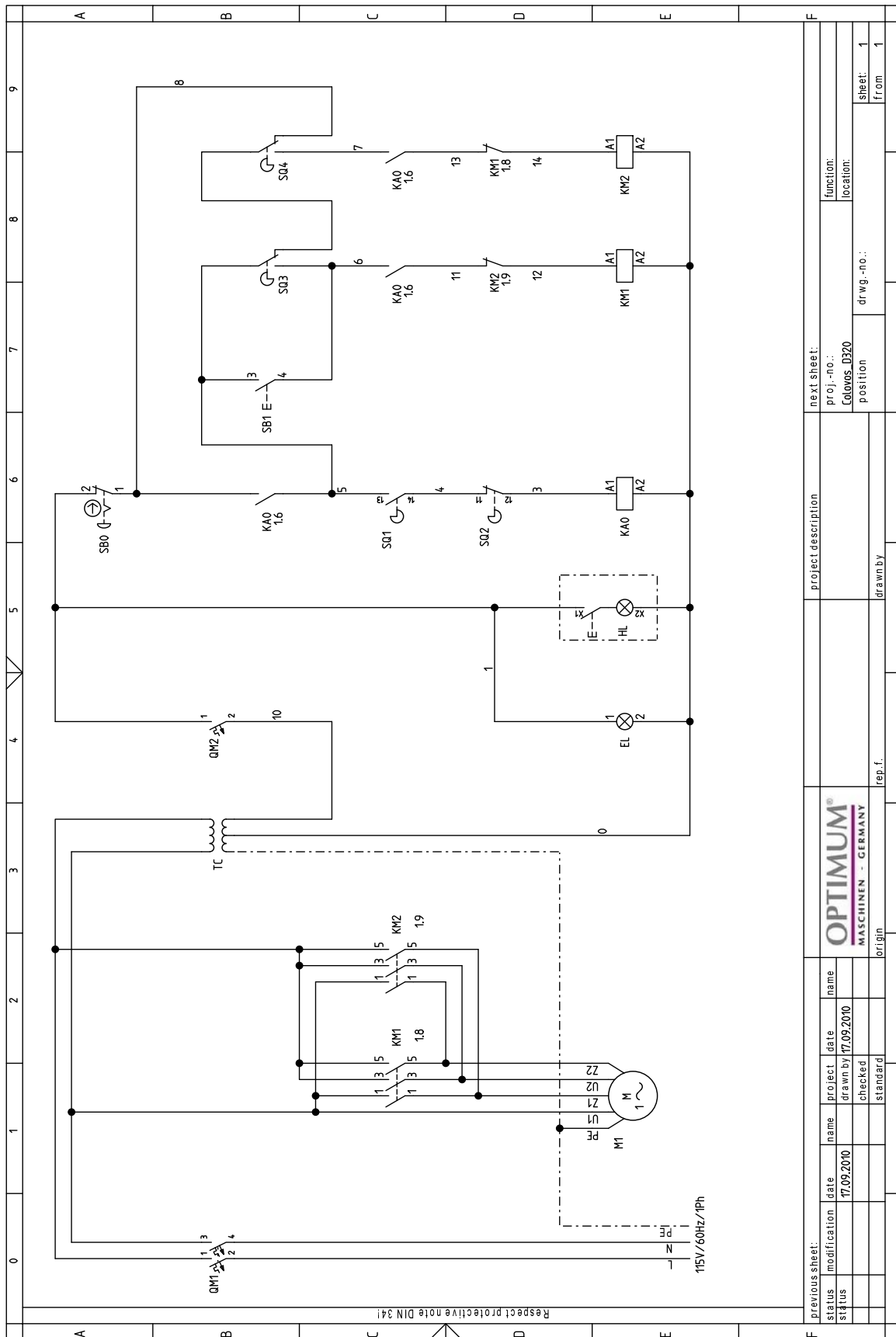





Illustr. 7-30: Wiring diagram

previous sheet:	next sheet:
status	proj.-no.:
modification	Colovus D320
status	location:
date	17.09.2010
name	position
project date	drwg.-no.:
drawn by	1
checked	sheet:
standard	from
origin	1
rep. f.	1
drawn by	
project description	
<b>OPTIMUM</b> MASCHINEN - GERMANY	

## 7.31.1 Spare part list electric components

Pos.	Description	Quantity	Size	Article no.
M1	Drive motor	1	1,5 kW/YL90L-4	03400928M1
TC	Transformer	1	JBK-100/24V	03400928TC
QM1	Circuit breaker	1	DZ47/2P/D15	03400928QM1
QM2	Circuit breaker	1	DZ47/2P/D1	03400928QM2
KM1	Contactor	1	3TB4322/24V/50Hz	03400928KM1
KM2	Contactor	1	3TB4322/24V/50Hz	03400928KM2
KA0	Contactor	1	3TH8040/24V/50Hz	03400928KA0
SB0	Emergency stop button	1	LA103-01ZS/1	03400928SB0
SB1	Button direct run	1	LA103-10	03400928SB1
EL	Machine light	1	JC34A/24V/50W	03400928EL
HL	Power lamp	1	LA103-XD/24V	03400928HL
SQ1	Position switch protection jaw chuck	1	LXW5-11Q1	03400928SQ1
SQ2	Position switch protection head stock cover	1	LXW5-11Q	03400928SQ2
SQ3	Switch forward	1	LXW5-11D1	03400928SQ3
SQ4	Switch backwards	1	LXW5-11D1	03400928SQ4

## 8 Malfunctions

Malfunction	Cause / possible effects	Solution
The lathe does not start	<ul style="list-style-type: none"> <li>The position switch of the lathe chuck guard switches the lathe off.</li> <li>The position switch of the protective cover on the headstock switches the lathe off.</li> <li>EMERGENCY-STOP button actuated.</li> <li>Thermal overload QM1 switch activated (tripped).</li> </ul>	<ul style="list-style-type: none"> <li>Check and adjust the position switch of the lathe chuck guard.</li> <li>Check and adjust the position switch of the protective cover on the headstock.</li> <li>Release the EMERGENCY-STOP button.</li> <li>Open control box and reset QM1 thermal overload switch.</li> <li> „Power connection“ on page 27</li> </ul>
The control lamp for operation is not on.	<ul style="list-style-type: none"> <li>Thermal overload QM1 switch activated.</li> <li>control transformer is defective</li> <li>control lamp for operation is defective</li> </ul>	<ul style="list-style-type: none"> <li>Open control box and reset QM1 thermal overload switch.</li> <li>replace transformer</li> <li>replace control lamp for operation</li> </ul>
Motor is humming Motor gets hot Motor has no power	<ul style="list-style-type: none"> <li>Defective starting capacitor</li> <li>the machine is connected incorrectly.</li> <li>defective motor.</li> </ul>	<ul style="list-style-type: none"> <li>Replace starting capacitor.</li> <li> „Power connection“ on page 27</li> <li>Replace motor</li> </ul>
Surface of the workpiece too rough	<ul style="list-style-type: none"> <li>tool blunt</li> <li>tool springs</li> <li>feed too high</li> <li>radius at the tool tip too high</li> </ul>	<ul style="list-style-type: none"> <li>resharpen tool</li> <li>clamp tool with less overhang</li> <li>reduce feed</li> <li>increase radius</li> </ul>
V-belts squeak and slip	<ul style="list-style-type: none"> <li>V-belts defective, used</li> <li>tension of V-belts is too low</li> </ul>	<ul style="list-style-type: none"> <li> „control V-belt,“ on page 65</li> </ul>
Workpiece is becoming cone	<ul style="list-style-type: none"> <li>centers are not aligned (tailstock has offset)</li> <li>top slide is not well aligned (cutting with the top slide)</li> </ul>	<ul style="list-style-type: none"> <li>adjust tailstock to the center</li> <li> „Cross-adjustment of the tailstock“ on page 44</li> <li>well align top slide</li> </ul>
Lathe is chattering	<ul style="list-style-type: none"> <li>feed too high</li> <li>main bearings have clearance</li> </ul>	<ul style="list-style-type: none"> <li>reduce feed</li> <li>have the main bearing re-adjusted</li> </ul>
center turns hot	<ul style="list-style-type: none"> <li>workpiece has expanded</li> </ul>	<ul style="list-style-type: none"> <li>loosen tailstock tip</li> </ul>
Tool has a short edge life	<ul style="list-style-type: none"> <li>cutting speed too high</li> <li>crossfeed too high</li> <li>insufficient cooling</li> </ul>	<ul style="list-style-type: none"> <li>reduce cutting speed</li> <li>lower crossfeed (allowance not over 0.020")</li> <li>more coolant</li> </ul>
Flank wear too high	<ul style="list-style-type: none"> <li>clearance angle too small (tool "pushes")</li> <li>tool tip not adjusted to center height</li> </ul>	<ul style="list-style-type: none"> <li>increase clearance angle</li> <li>correct height adjustment of the tool</li> </ul>
Cutting edge breaks off	<ul style="list-style-type: none"> <li>wedge angle too small (heat building)</li> <li>grinding crack due to wrong cooling</li> <li>excessive clearance in the spindle bearing arrangement (vibrations)</li> </ul>	<ul style="list-style-type: none"> <li>increase wedge angle</li> <li>cool uniformly</li> <li>have the clearance in the spindle bearing arrangement re-adjusted</li> </ul>

Malfunction	Cause / possible effects	Solution
Cut thread is wrong	<ul style="list-style-type: none"> <li>• tool is clamped incorrectly or has been ground the wrong way</li> <li>• wrong pitch</li> <li>• wrong diameter</li> </ul>	<ul style="list-style-type: none"> <li>• adjust tool to the center, grind angle correctly.</li> <li>• adjust right pitch</li> <li>• in a previous step, turn the work-piece to the correct diameter</li> </ul>



## 9 Appendix

### 9.1 Copyright

© 2014

This document is copyright. All derived rights are also reserved, especially those of translation, re-printing, use of figures, broadcast, reproduction by photo-mechanical or similar means and recording in data processing systems, neither partial nor total.

The company reserves the right to make technical alternations without prior notice.

### 9.2 Terminology/Glossary

Term	Explanation
headstock	housing for the feed gear and the belt pulleys
leadscrew nut	split nut which engages in the leadscrew
lathe chuck	clamping tool for holding the workpiece
drill chuck	device for holding the bit
lathe saddle	slide on the slideway of the machine bed which feeds parallel to the tool axis
cross slide	slide on the lathe saddle which moves transversely to the tool axis
top slide	swivelling slide on the cross slide
taper mandrel	taper of the bit, the drill chuck or the center
tool	cutting tool, bit, etc.
workpiece	piece to be turned or machined
tailstock	movable turning aid
rest	follow or steady support for turning long workpieces
lathe dog	device or clamping aid for driving pieces to be turned between centers
threading gauge	auxiliary device for thread-cutting

### 9.3 LIMITED WARRANTY

**OPTIMUM ONE-YEAR LIMITED WARRANTY.** OPTIMUM, MODELS COVERED IN THIS MANUAL, ARE WARRANTED BY OPTIMUM TO THE ORIGINAL USER AGAINST DEFECTS IN WORKMANSHIP OR MATERIALS UNDER NORMAL USE FOR ONE YEAR AFTER DATE OF PURCHASE. ANY PART WHICH IS DETERMINED TO BE DEFECTIVE IN MATERIAL OR WORKMANSHIP AND RETURNED TO AN AUTHORIZED SERVICE LOCATION, AS OPTIMUM DESIGNATES, SHIPPING COSTS PREPAID, WILL BE, AS THE EXCLUSIVE REMEDY, REPAIRED OR REPLACED AT OPTIMUM OPTION. FOR LIMITED WARRANTY CLAIM PROCEDURES, SEE "PROMPT DISPOSITION" BELOW. THIS LIMITED WARRANTY GIVES PURCHASERS SPECIFIC LEGAL RIGHTS WHICH VARY FROM JURISDICTION TO JURISDICTION.

**LIMITATION OF LIABILITY.** TO THE EXTENT ALLOWABLE UNDER APPLICABLE LAW, OPTIMUM LIABILITY FOR CONSEQUENTIAL AND INCIDENTAL DAMAGES IS EXPRESSLY DISCLAIMED. OPTIMUM LIABILITY IN ALL EVENTS IS LIMITED TO AND SHALL NOT EXCEED THE PURCHASE PRICE PAID.

**WARRANTY DISCLAIMER.** A DILIGENT EFFORT HAS BEEN MADE TO PROVIDE PRODUCT INFORMATION AND ILLUSTRATE THE PRODUCTS IN THIS LITERATURE ACCURATELY; HOWEVER, SUCH INFORMATION AND ILLUSTRATIONS ARE FOR THE SOLE PURPOSE OF IDENTIFICATION, AND DO NOT EXPRESS OR IMPLY A WARRANTY THAT THE PRODUCTS ARE MERCHANTABLE, OR FIT FOR A PARTICULAR PURPOSE, OR THAT THE PRODUCTS WILL NECESSARILY CONFORM TO THE ILLUSTRATIONS OR DESCRIPTIONS. EXCEPT AS PROVIDED BELOW, NO WARRANTY OR AFFIRMATION OF FACT, EXPRESSED OR IMPLIED, OTHER THAN AS STATED IN THE "LIMITED WARRANTY" ABOVE IS MADE OR AUTHORIZED BY OPTIMUM.

**Technical Advice and Recommendations, Disclaimer.** Notwithstanding any past practice or dealings or trade custom, sales shall not include the furnishing of technical advice or assistance or system design. OPTIMUM assumes no obligations or liability on account of any unauthorized recommendations, opinions or advice as to the choice, installation or use of products.

**Product Suitability.** Many jurisdictions have codes and regulations governing sales, construction, installation, and/or use of products for certain purposes, which may vary from those in neighboring areas. While attempts are made to assure that OPTIMUM products comply with such codes, OPTIMUM cannot guarantee compliance, and cannot be responsible for how the product is installed or used. Before purchase and use of a product, review the product applications, and all applicable national and local codes and regulations, and be sure that the product, installation, and use will comply with them.

Certain aspects of disclaimers are not applicable to consumer products; e.g., (a) some jurisdictions do not allow the exclusion or limitation of incidental or consequential damages, so the above limitation or exclusion may not apply to you; (b) also, some jurisdictions do not allow a limitation on how long an implied warranty lasts, consequently the above limitation may not apply to you; and (c) by law, during the period of this Limited Warranty, any implied warranties of implied merchantability or fitness for a particular purpose applicable to consumer products purchased by consumers, may not be excluded or otherwise disclaimed.

**Prompt Disposition.** A good faith effort will be made for prompt correction or other adjustment with respect to any product which proves to be defective within limited warranty. For any product believed to be defective within limited warranty, first write or call dealer from whom the product was purchased. Dealer will give additional directions. If unable to resolve satisfactorily, write to OPTIMUM at address below, giving dealer's name, address, date, and number of dealer's invoice, and describing the nature of the defect. Title and risk of loss pass to buyer on delivery to common carrier. If product was damaged in transit to you, file claim with carrier.

**Manufactured for OPTIMUM, LDS Industries, LLC, 930 W. National Ave. Addison, IL 60101, Tel.: 1-630-785-6437.**

## 10 Index

### A

Accident report .....	16
Anchored assembly .....	27
Anchoring-free assembly .....	26
Assembly .....	25
Anchored .....	27
Anchoring-free .....	26
Workpiece holder .....	37, 38
assembly	
rests .....	39

### C

coolant .....	47
Copyright .....	113
Cross-adjustment of the tailstock .....	44
Cutting speed table .....	55
Cutting speeds .....	55

### D

Dimensions .....	18
------------------	----

### E

Electrical system .....	16
EMERGENCY-STOP button .....	11

### F

Feed table .....	39
First use .....	27
Functional check .....	27
Functional test .....	30

### I

Installation .....	26
--------------------	----

### L

Lathe accessories, optional .....	22
Lathe chuck protection	
Headstock .....	12
Load end position .....	25

### M

Main switch .....	11
Mechanical maintenance work .....	16

### O

Obligations	
Operator .....	9

### P

Personal protective equipment .....	14
Power connection	
electrical .....	17
Prohibition, warning and mandatory labels .....	13
Protective equipment .....	14

### Q

Qualification of employees	
Safety .....	9

### S

Speed table .....	34
Switching off the lathe .....	15

### T

Table for thread cutting .....	41
Tailstock .....	44
Transport .....	23

tread-cutting .....	47
Turning speeds .....	49

### U

Use of lifting equipment .....	15
--------------------------------	----

### W

Work area .....	18
-----------------	----