

# INSTRUCTION MANUAL

## DS10



**KALAMAZOO  
INDUSTRIES, INC.**

6856 East K Avenue

Kalamazoo, MI 49048

269-382-2050 PH

269-382-0790 FAX

[www.kalamazooindustries.com](http://www.kalamazooindustries.com)



1SM M8-02

## DISC SANDER (Model DS-10)

ITEM	PART NO.	DESCRIPTION
1	050-022	Base
2	342-029	Guard
3	160-001	Sanding Disc Holder
4	PSA	Paper (Sanding Disc)
5	829-014	Table Assembly
6	441-017	Holding Knob
7		Spacer
8		Weld Nut
9	486-001	Motor - ½ H.P. 1725 RPM W/ Cord & Off & On Switch
10		Mach. Screw - ¼ -20 x ¾ W/ Flat Washer, Lock Washer & Nut
11		Set Screw

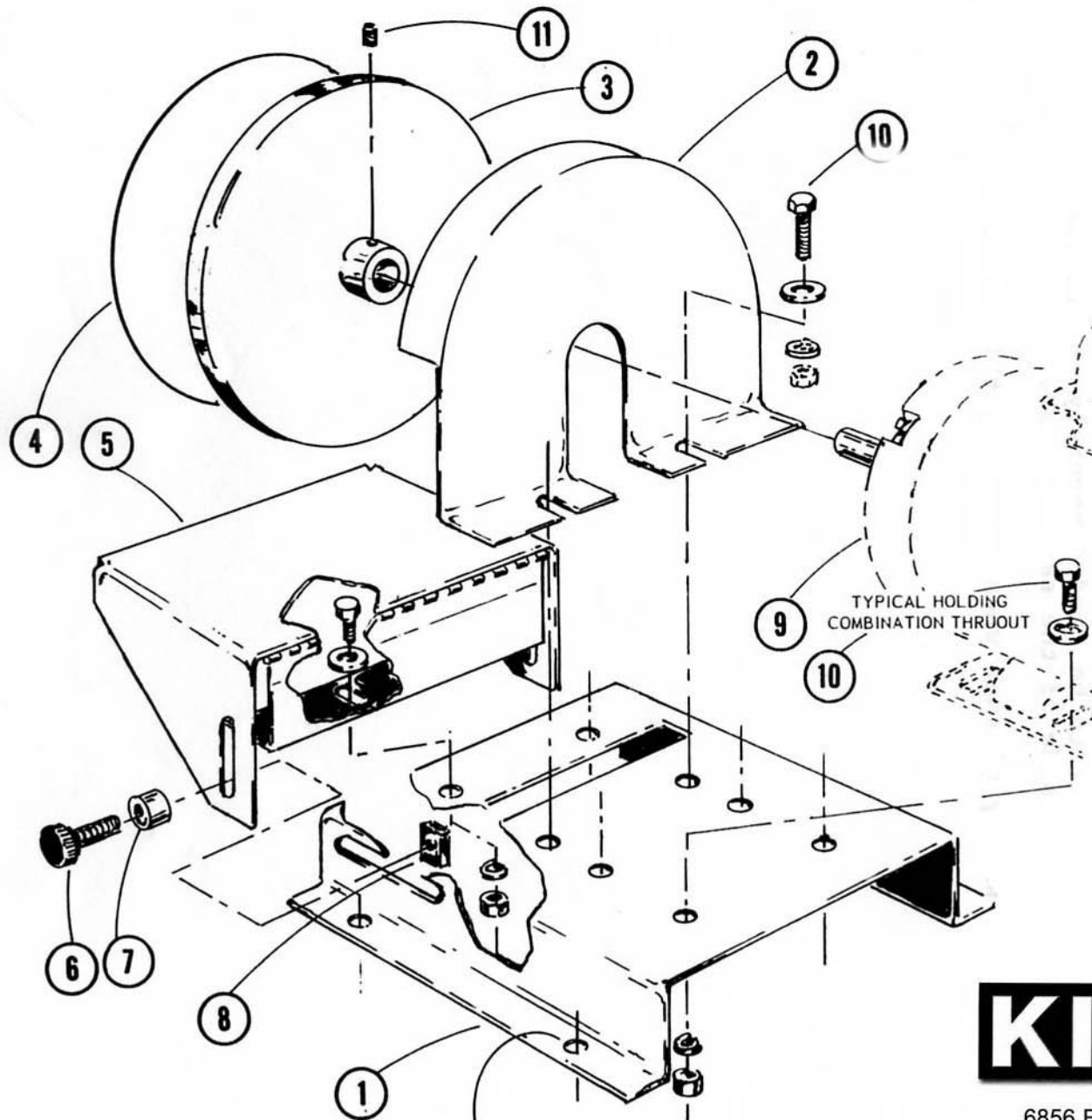

Model DS10

**KI KALAMAZOO INDUSTRIES, INC.**

6856 East K Avenue - Kalamazoo, MI 49048-6042

Phone 269-382-2050 Fax 269-382-0790

[www.kalamazooindustries.com](http://www.kalamazooindustries.com)

## **WARRANTY**

All products are guaranteed for a period of one year to the original purchaser, against defects in material workmanship under normal use. Electric motors are warranted by the motor manufacturer and will be repaired by the nearest motor repair station. If non-repairable, they will be replaced by Kalamazoo Industries. Please call for instructions 269-382-2050.

## **RETURN POLICY**

Authorization must be obtained before returning merchandise. Please call our customer service department for a return authorization number at 269-382-2050. Please include with your return a copy of your invoice or packing slip. Materials must be sent back prepaid. (Unless otherwise indicated). All returns will be subject to a 10% restocking charge. No returns will be accepted after one year of invoice date.

## **BELT SANDER SAFETY**

- READ THE OPERATING INSTRUCTIONS BEFORE RUNNING MACHINE.
- ALWAYS WEAR SAFETY GLASSES OR A FULL FACE SHIELD FOR PROTECTION.
- KEEPS HANDS CLEAR OF THE SANDING AREA.
- NEVER WEAR GLOVES OR LOOSE FITTING CLOTHES WHEN OPERATING THIS MACHINE.
- ALWAYS KEEP HAIR TIED BACK OR COVERED.
- LET MACHINE ROTATION COME TO A FULL STOP BEFORE CHANGING BELT.
- KEEP SAFETY GUARDS IN PLACE. DO NOT ALTER GUARDS OR MACHINE IN ANY WAY. ANY ALTERATIONS TO GUARDS OR MACHINE COULD CAUSE SERIOUS INJURY.
- ALL BELT SANDERS SHOULD BE OPERATED IN A WELL-VENTILATED AREA. THE DUST CREATED WHEN SOME MATERIALS ARE SANDED CAN BE HARMFUL. DUST MASKS ARE RECOMMENDED AS A PRACTICAL MEANS OF MINIMIZING DUST INHALATION. FUMES FROM OTHER SOURCES CAN ALSO CAUSE FIRES WHEN IN CONTACT WITH SANDING SPARKS.
- SPARKS CREATED BY SANDING SHOULD BE DIRECTED DOWNWARD AND AWAY FROM THE FACE AND BODY. DO NOT GRIND NEAR FLAMMABLE MATERIAL.
- ELECTRIC SANDING MACHINES ARE NOT INTENDED FOR USE IN OR NEAR WATER. THIS INCLUDES AN OPERATOR STANDING ON A WET FLOOR OR WORKING AROUND CONTAINERS OF WATER OR OTHER CONDUCTIVE LIQUIDS.

**KALAMAZOO INDUSTRIES, INC.**  
6856 East K Avenue  
Kalamazoo, MI 49048  
269-382-2050 PH  
269-382-0790 FAX  
[www.kalamazooindustries.com](http://www.kalamazooindustries.com)



Made in USA



6856 East K Avenue - Kalamazoo, MI 49048-6042  
Phone 269-382-2050 Fax 269-382-0790  
[www.kalamazooindustries.com](http://www.kalamazooindustries.com)

## DS10

### Basic Operation:

Specs: ½ HP , 1 phase 110/220 volt, 1725 rpm

Disc size: 10", PSA discs

1. Be sure AC incoming power matches the DS10. The DS10 ships standard as 1 phase, 110 volts but the motor is dual voltage 110/220 1 phase. It can be re-wired to 1/220 volts if needed at the motor junction box. An electrical schematic sticker on the motor indicates the wiring for voltage changes. **CAUTION: IF NOT FAMILIAR WITH ELECTRICS CONSULT AN ELECTRICIAN.**
2. Disc: The 10" disc uses PSA (pressure sensitive adhesive) discs. Peel back the clear backing and stick the disc to the aluminum disc holder. Consult your dealer for PSA discs.
3. Disc table: The disc table will tilt downward for angles. Loosen the knobs on either side of the table to tilt, re-lock to maintain position. Keep the table within 1/8" of the disc for safety.
4. Follow all safety procedures. **SEE SAFETY SHEET.**