

**INSTRUCTION
MANUAL
MODEL NO.
K20SW**



**KALAMAZOO
INDUSTRIES, INC.**

6856 East K Avenue

Kalamazoo, MI 49048

269-382-2050 PH

269-382-0790 FAX

www.kalamazooindustries.com

WARNING!

TO REDUCE THE RISK OF FIRE OR SHOCK HAZARD,
DO NOT EXPOSE THIS EQUIPMENT TO RAIN, ANY LIQUID OR MOISTURE.

READ AND UNDERSTAND ALL SAFETY PRECAUTIONS AND OPERATING INSTRUCTIONS BEFORE OPERATING UNIT

OPERATING INSTRUCTIONS

INSPECT YOUR NEW UNIT CAREFULLY FOR SIGNS OF SHIPPING DAMAGE. IF DAMAGED, PLEASE CONTACT CARRIER AND SUBMIT A CONCEALED DAMAGED REPORT. DO NOT RETURN GOODS TO US WITHOUT OUR RGA NUMBER AND SHIPPING INSTRUCTIONS. SEE BACK PAGE FOR RETURN POLICY AND WARRANTY.

BEFORE STARTING OR CONNECTING ELECTRICALS VERIFY THE PHASE AND VOLTAGE OF THE UNIT.

BE SURE MACHINE IS BALANCED CORRECTLY SO IT WILL NOT TIP OVER.

TO GUARD AGAINST CONCEALED DAMAGE, STAND CLEAR AND OBSERVE UNIT FOR THE FIRST FEW MINUTES OF OPERATION. GUARDS MUST NEVER BE REMOVED.

ABRASIVE SAW SAFETY

NEVER REMOVE SAFETY GUARDS FROM MACHINE. DISCONNECT POWER SOURCE BEFORE MAKING ANY MACHINE ADJUSTMENTS

ELECTRIC MACHINES ARE NOT INTENDED FOR USE IN OR NEAR WATER. THIS INCLUDES AN OPERATOR STANDING ON A WET FLOOR.

DO NOT USE AROUND FLAMMABLE MATERIALS OR LIQUIDS.

MACHINES SHOULD BE OPERATED IN VENTILATED AREAS.

ALWAYS WEAR SAFETY GLASSES OR A FULL FACE SHIELD FOR PROTECTION.

KEEP HANDS CLEAR OF THE CUTTING AREA.

DO NOT WEAR GLOVES OR LOOSE FITTING CLOTHES WHEN OPERATING THIS MACHINE.

ALWAYS KEEP HAIR TIED BACK OR COVERED.

ALWAYS KEEP FLANGES CLEAN AND TIGHT AGAINST CUTTING WHEEL.

ABRASIVE MACHINES ARE FOR ABRASIVE WHEELS NOT STEEL TOOTHED BLADES. DO NOT ATTEMPT TO USE STEEL BLADES UNLESS CORRECTLY GUARDED WITH AN ENCLOSED WHEEL GUARD. KEEP STEEL BLADES FULLY RETRACTED INTO WHEEL GUARD WHEN DONE CUTTING.

ALWAYS KEEP WHEEL GUARD IN DOWN POSITION.

BE SURE WORK PIECE IS CLAMPED SECURELY IN VISE BEFORE CUTTING.

WARNING!!!

IMPROPER USE MAY CAUSE BREAKAGE AND SERIOUS INJURY.

DO

1. DO always handle and store wheels in a careful manner.
2. DO visually inspect all wheels before mounting for possible damage.
3. DO check machine speed against the established maximum safe operating speed marked on the wheel.
4. DO check mounting flanges for equal and correct diameter.
5. DO use mounting blotters when supplied with wheels.
6. DO always use a safety guard covering at least one-half of the abrasive wheel.
7. DO allow newly mounted wheels to run at operating speed, with guard in place, for at least one minute before cutting.
8. DO always wear safety glasses or some type of eye protection when cutting.

DON'T

1. DON'T use a cracked wheel or one that has been dropped or has become damaged.
2. DON'T force a wheel onto the machine or alter the size of the mounting hole-if wheel won't fit the machine, get one that will.
3. DON'T ever exceed maximum operating speed established for the wheel.
4. DON'T use mounting flanges on which the bearing surfaces are not clean, flat and free of burrs.
5. DON'T tighten the mounting nut excessively.
6. DON'T start the machine until the wheel guard is in place.
7. DON'T jam work into wheel.
8. DON'T force cutting so that motor slows noticeably or work gets hot.
9. DON'T wear gloves when operating machine.

Basic Operation

K20SW, 15 hp, 3 phase 220/440 volt ,magnetic switch.
All above 1” spindle arbor, RH thread.

Electrics- Be sure of incoming AC power and verify machine power is the same as incoming AC power. CAUTION: IF NOT FAMILIAR WITH ELECTRICALS CONSULT AN ELECTRICIAN.!!! Follow all safety procedures. SEE ABRASIVE SAFETY SHEET!!!

K20SW-15 hp in 220/440 volt uses a magnetic switch. Drill/punch NEMA enclosure to accept seal tite fitting, input power to L1, L2, L3 on the contactor. CAUTION: Voltage changes require wire lead changes at motor, transformer & fuses. IF NOT FAMILIAR WITH ELECTRICS CONSULT AN ELECTRICIAN.!!! CHANGES FROM FACTORY SETTINGS ARE NOT COVERED UNDER WARRANTY UNLESS AUTHORIZED FROM THE FACTORY.!!

Abrasive wheels- Select the correct abrasive wheel for the material being cut. Consult your dealer for correct wheel selection. Abrasive wheels vary in grit, bond, etc.. Good cuts are not burnt or discolored but bright like the outside of the material. If material being cut is binding, pinching the wheel, burning then the wrong wheel is being used. Many times it may take several test cuts with different wheels to get the best performance. Inform your dealer of the material , size, shape being cut so as to select the right abrasive wheel.

Cutting- Be sure material is held securely while cutting. NO MOVEMENT of material should occur when cutting or wheel failure will result. Use constant steady manual pressure when pulling down the saw head. To light of pressure will cause loading of wheel. Be sure no flammable material is nearby to cause a fire. Follow safety procedures like safety glasses, face shields, etc. SEE ABRASIVE SAFETY SHEET.!!

Chain Vise- Pull chain over material as tight as possible, insert closest chain link into clevis on back of fence (#23). Use vise open/close valve to tighten chain around material. Do not allow material to move during cutting!! Wheel breakage will occur. Input shop air 0-100 PSI into regulator for vise air pressure.

Coolant- Use a rust inhibiting grinding type coolant. Consult your dealer for coolant.

Maintenance- Keep drive V belts tight. (1/2” of squeeze) Do not over tighten. After initial start up and use re-check V belt tension . All bearings are sealed bearings and need no attention. Keep machine and area clean of abrasive dust.

MODEL K20SW/ K20E

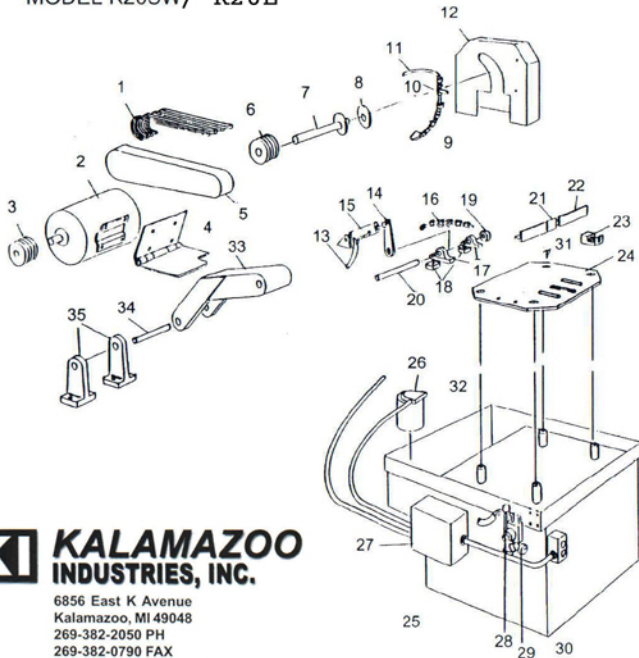

NO.	PART NO.	DESCRIPTION	QTY
1	051-005	V-BELT	4
2	486-020	15HP SD MOTOR	1
	486-009	20HP MOTOR	1
3	560-019	MOTOR PULLEY-15HP	1
	560-021	MOTOR PULLEY-20HP	1
4		MOTOR MOUNT	1
5	342-039	BELT GUARD	1
6	560-020	SPINDLE PULLEY-15HP	1
	560-022	SPINDLE PULLEY-20HP	1
7	701-010	SPINDLE W/TIGHT FLANGE	1
8	292-011	LOOSE FLANGE	1
9		FLEXIBLE HOSE W/NOZZLE	1
10		COOLANT VALVE	1
11		COOLANT HOSE	1
12	342-013	WHEEL GUARD	1
13		AIR LINE	2
14	002-015	ARM PIVOT	1
15		CYLINDER	1
16		24" LONG CHAIN	1
17		PILLOW BLOCK	2
18	699-027	SPACER	2
19	560-036	PULLEY, FOR CHAIN	1
20	700-015	SHAFT, FOR CHAIN	1
21	293-013	FENCE L.H.	1
22	293-014	FENCE R.H.	1
23	053-011	BLOCK, CHAIN ANCHOR	1
24	556-037	PLATE, TOP	1
25	716-019W	STAND ASSEMBLY	1
26	716-011	COOLANT PACKAGE	1
27	710-006	MAGNETIC SWITCH	1
28	912-014	4-WAY VALVE	1
29	912-006	AIR GAGE & REGULATOR	1
30		PUSH BUTTON SWITCH	1
31		1/2x13x1-5/8 FHSS	4
32	576-005	PAN COOLANT	1
33	002-005	ARM PIVOT	1
34	700-002	TRUNNION PIN	1
35	831-002	TRUNION	2



**KALAMAZOO
INDUSTRIES, INC.**

6856 East K Avenue
Kalamazoo, MI 49048
269-382-2050 PH
269-382-0790 FAX

www.kalamazooindustries.com

KALAMAZOO INDUSTRIES FILE# 24

MODEL #K20SW	460 VOLT 3Ø
OVERLOAD HEATERS	
DRIVE MOTOR	H-37
OCILLATOR MOTOR	M-8
PUMP MOTOR	M-7

08/31/92

(optional)
SAW ONLY OCILLATE SAW

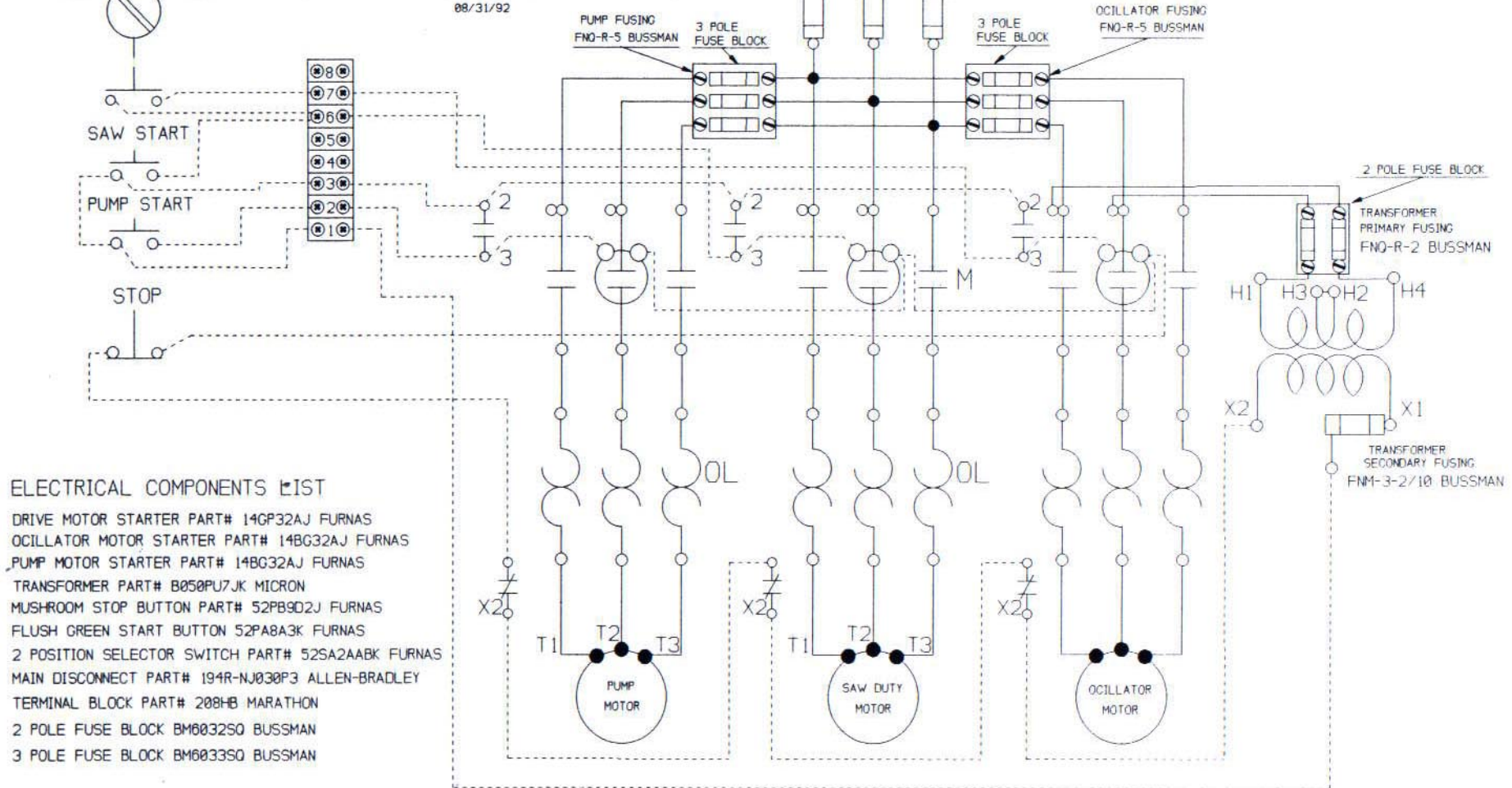

ELECTRICAL COMPONENTS LIST

- DRIVE MOTOR STARTER PART# 14GP32AJ FURNAS
- OCILLATOR MOTOR STARTER PART# 14BG32AJ FURNAS
- PUMP MOTOR STARTER PART# 14BG32AJ FURNAS
- TRANSFORMER PART# B050PU7JK MICRON
- MUSHROOM STOP BUTTON PART# 52PB9D2J FURNAS
- FLUSH GREEN START BUTTON 52PA8A3K FURNAS
- 2 POSITION SELECTOR SWITCH PART# 52SA2AABK FURNAS
- MAIN DISCONNECT PART# 194R-NJ030P3 ALLEN-BRADLEY
- TERMINAL BLOCK PART# 208HB MARATHON
- 2 POLE FUSE BLOCK BM6032SQ BUSSMAN
- 3 POLE FUSE BLOCK BM6033SQ BUSSMAN

(optional)



KALAMAZOO INDUSTRIES, INC.

6856 East K Avenue
Kalamazoo, MI 49048
269-382-2050 PH
269-382-0790 FAX
www.kalamazooindustries.com

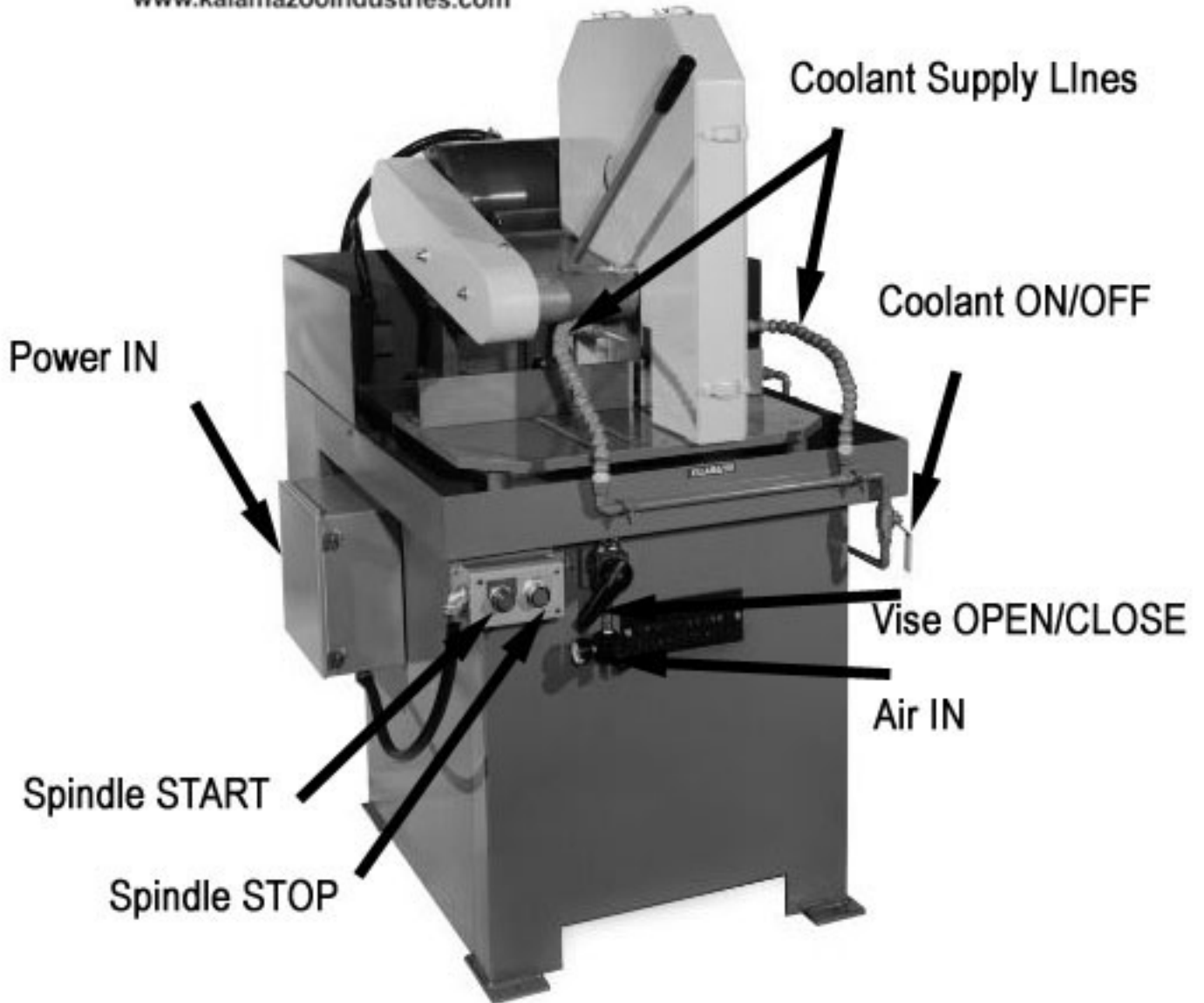

Model: K20SW 20" dia. wet abrasive saw
Table Dims: 27"w x 30"deep