

# PALMGREN

## 2 x 6" BELT & DISC SANDER

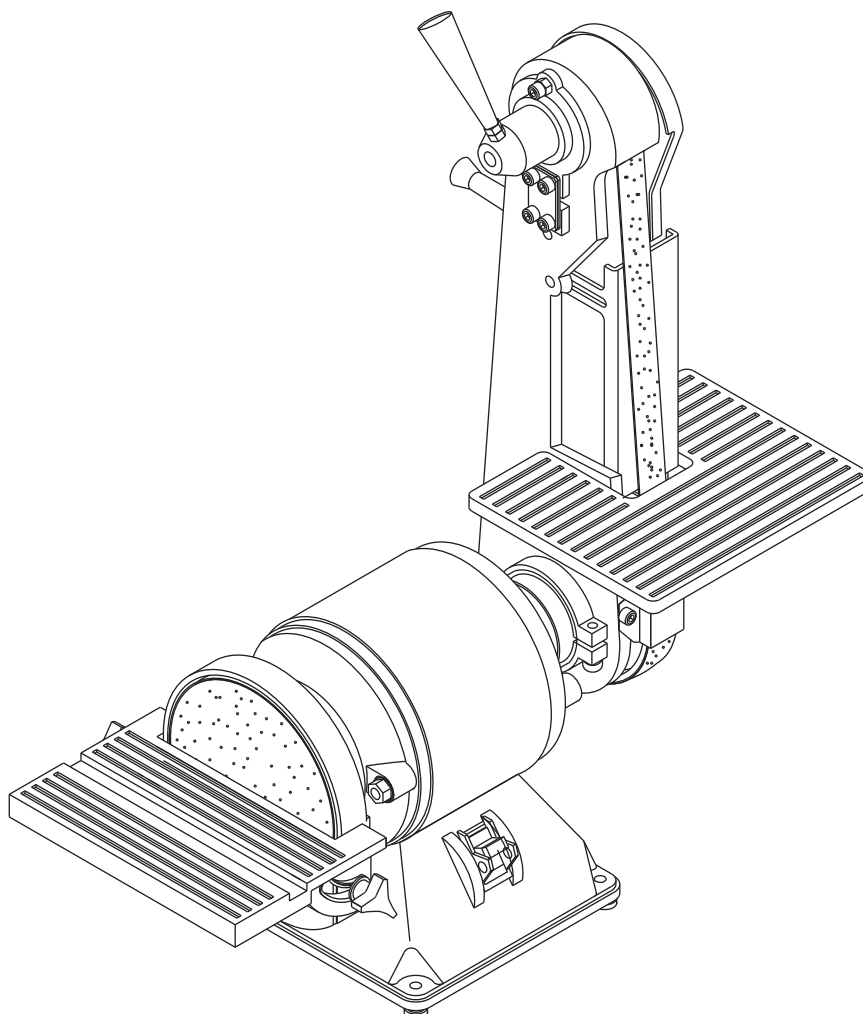

***Read carefully and follow all safety rules and operating instructions before first use of this product.***

**DESCRIPTION**

Palmgren 2 x 6" Belt and Disc Sander has a 2 x 42" belt and 6" disc for deburring, beveling and sanding wood, plastic and metal. The sander has a totally enclosed, fan-cooled 1/3 HP motor. Belt speed is 4400 FPM and the disc rotates 3500 RPM. The belt table tilts 0 to 60° and the disc table tilts 0 to 45° for angle sanding. The quick release tension and tracking mechanism makes belt changing quick and easy. Belt platen is removable for contour sanding. Belt housing swivels from horizontal to vertical for sanding long workpieces. Sanding disc has a 1½" dust collection chute.

**UNPACKING**

Refer to Figure 1.

Check for shipping damage. If damage has occurred, a claim must be filed with carrier. Check for completeness. Immediately report missing parts to dealer.

The sander comes assembled as one unit. Additional parts which need to be fastened to sander, should be located and accounted for before assembling.

- A Disc table
- B Abrasive disc
- C Miter gauge assembly
- D Belt table

Parts bag includes: one 10-1.50 x 25mm socket head bolt, one 10mm flat washer, one 10mm lock washer, two 6mm washers, one 8-1.25mm hex nut, horizontal stop bar with nut, work stop, two knobs, two pointers, two 4-0.7 x 8 mm socket head bolts, one 8mm flat washer, two 4mm flat washers, one each -- 3, 5, 6 and 8 mm hex wrenches and one extra long 4mm hex wrench.

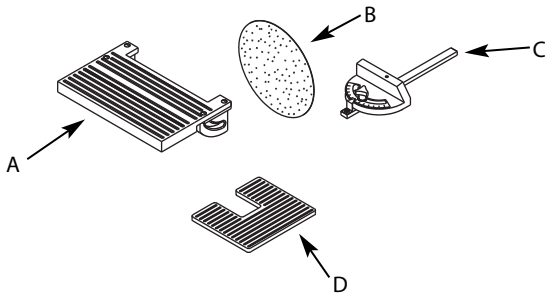

Figure 1 – Unpacking

**SPECIFICATIONS**

Belt size	.....2 x 42", 80 grit
Belt platen area	.....7¼ x 2"
Belt table dimensions	.....6¾ x 9"
Belt table tilts	.....0 to 60°
Belt speed	.....4400 FPM
Disc diameter	.....6", 80 grit
Disc table dimensions	.....5 <sup>7</sup> / <sub>16</sub> x 8 <sup>3</sup> / <sub>16</sub> "
Disc table tilts	.....0 to 45°
Disc dust chute diameter	.....1½"
Disc speed	.....3500 RPM
Base dimensions	.....8 <sup>9</sup> / <sub>32</sub> x 9 <sup>1</sup> / <sub>16</sub> "
Switch	......SP, Locking rocker
Motor	.....1/3 HP, 120V, 3.5 AMPS
Weight	......32 lbs
Shipping Weight	......35 lbs

**SAFETY RULES**

**WARNING:** For your own safety, read all of the instructions and precautions before operating tool.

**CAUTION:** Always follow proper operating procedures as defined in this manual even if you are familiar with use of this or similar tools. Remember that being careless for even a fraction of a second can result in severe personal injury.

**WARNING:** Some dust created by power sanding, sawing, grinding, drilling and other construction activities contains chemicals known to cause cancer, birth defects or other reproductive harm. Some examples of these chemicals are:

- Lead from lead-based paints.
- Crystalline silica from bricks and cement and other masonry products.
- Arsenic and chromium from chemically-treated lumber.

Your risk from these exposures vary, depending on how often you do this type of work. To reduce your exposure to these chemicals: work in a well ventilated area and work with approved safety equipment. Always wear **OSHA/NIOSH** approved, properly fitting face mask or respirator when using such tools.

**BE PREPARED FOR JOB**

- Wear proper apparel. Do not wear loose clothing, gloves, neckties, rings, bracelets or other jewelry which may get caught in moving parts of machine.
- Wear protective hair covering to contain long hair.
- Wear safety shoes with non-slip soles.
- Wear safety glasses complying with United States ANSI Z87.1. Everyday glasses have only impact resistant lenses. They are **NOT** safety glasses.
- Wear face mask or dust mask if operation is dusty.
- Be alert and think clearly. Never operate power tools when tired, intoxicated or when taking medications that cause drowsiness.

**PREPARE WORK AREA FOR JOB**

- Keep work area clean. Cluttered work areas and work benches invite accidents.
- Do not use power tools in dangerous environments. Do not use power tools in damp or wet locations. Do not expose power tools to rain.
- Work area should be properly lighted.
- Proper electrical receptacle should be available for tool. Three-prong plug should be plugged directly into properly grounded, three-prong receptacle.
- Extension cords should have a grounding prong and the three wires of the extension cord should be of the correct gauge.
- Keep visitors at a safe distance from work area.
- Keep children out of the workplace. Make workshop childproof. Use padlocks, master switches or remove switch keys to prevent any unauthorized use of power tools.

**TOOL SHOULD BE MAINTAINED**

- Always unplug tool prior to inspection.
- Consult manual for specific maintaining and adjusting procedures.
- Keep tool lubricated and clean for safest operation.
- Remove adjusting tools. Form habit of checking to see that adjusting tools are removed before switching machine on.

**SAFETY RULES (CONTINUED)**

- Keep all parts in working order. Check to determine that the guard or other parts will operate properly and perform their intended function.
- Check for damaged parts. Check for alignment of moving parts, binding, breakage, mounting and any other condition that may affect a tool's operation.
- A guard or other part that is damaged should be properly repaired or replaced. Do not perform makeshift repairs. (Use the parts list to order replacement parts.)

**KNOW HOW TO USE TOOL**

- Use right tool for job. Do not force tool or attachment to do a job for which it was not designed.
- Disconnect tool from power when changing abrasive belt or disc.
- Avoid accidental start-up. Make sure that the switch is in the OFF position before plugging in.
- Do not force tool. It will work most efficiently at the rate for which it was designed.
- Keep hands away from moving parts and sanding surfaces.
- Never leave tool running unattended. Turn the power off and do not leave tool until it comes to a complete stop.
- Do not overreach. Keep proper footing and balance.
- Never stand on tool. Serious injury could occur if tool is tipped or if belt or disc are unintentionally contacted.
- Know your tool. Learn the tool's operation, application and specific limitations.
- Handle workpiece correctly. Protect hands from possible injury.
- Turn machine off if it jams. Belt jams when it digs to deeply into workpiece. (Motor force keeps it stuck in the work).
- Support workpiece with miter gauge, belt platen or work table.
- Maintain  $\frac{1}{16}$ " maximum clearance between table and sanding belt or disc.

**CAUTION:** Think safety! Safety is a combination of operator common sense and alertness at all times when tool is being used.

**WARNING:** Do not attempt to operate tool until it is completely assembled according to instructions.

## ASSEMBLY

Refer to Figures 2 and 3.

**CAUTION:** Do not attempt assembly if parts are missing. Use this manual to order replacement parts.

**ATTACH ABRASIVE DISC TO ALUMINUM DISC**

Refer to Figure 2.

- Remove dust chute by loosening screws and bolts.
- Remove the adhesive cover from the back of the abrasive disc.
- Center abrasive on aluminum disc and press to paste.
- Make sure abrasive is pasted evenly on the aluminum disc.
- Replace dust chute.

**ATTACH DISC TABLE**

Refer to Figure 2.

- Set the disc table at right angle to the aluminum disc and secure the table position using two knobs and flat washers. Be sure that the gap between abrasive disc and disc table is  $\frac{1}{16}$ " or less.
- Attach pointers to sides of dust chute using 4-0.7 x 8mm socket head bolts from hardware bag. Adjust pointers to zero mark on trunnion and tighten bolts.

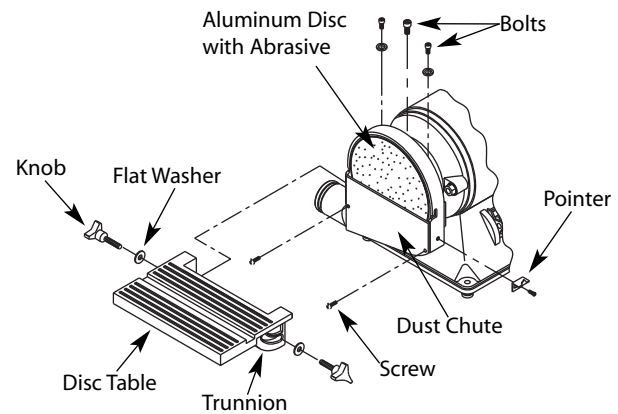

**Figure 2 - Secure Disc Table and Aluminum Disc  
ATTACH BELT TABLE**

Refer to Figure 3.

- Attach belt table to left side of belt housing using the socket head bolt, flat washer and lock washer from the hardware bag.
- Set the belt table at right angle to the belt.
- Be sure that gap between belt table and belt is  $\frac{1}{16}$ " or less.
- Tighten socket head bolt to secure belt table position.

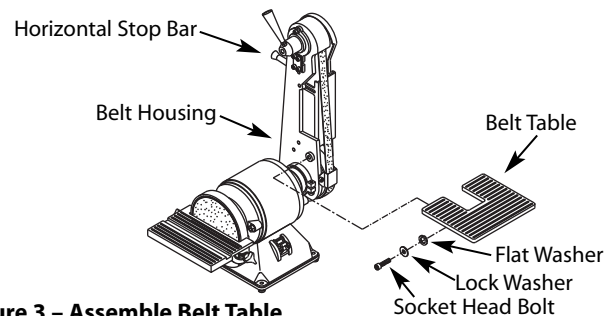

**Figure 3 - Assemble Belt Table  
ATTACH HORIZONTAL STOP**

Refer to Figure 3.

A horizontal stop bar with nut is provided as a positive stop when using the sander with the belt housing adjusted to a horizontal position. To attach stop bar:

- Thread the horizontal stop bar into the threaded hole on the rear side of belt housing.
- Tighten hex nut.

## INSTALLATION

Refer to Figures 4, 5 and 6.

**WARNING:** All electrical connections must be performed by a qualified electrician.

**POWER SOURCE**

The motor is designed for operation on the voltage and frequency specified. Normal loads will be handled safely on voltages not more than 10% above or below the specified voltage.

Running the unit on voltages which are not within the range may cause overheating and motor burnout. Heavy loads require that voltage at motor terminals be no less than the voltage specified on nameplate. Power supply to the motor is controlled by a single pole locking rocker switch. Remove the key to prevent unauthorized use.

**INSTALLATION (CONTINUED)**

**GROUNDING INSTRUCTIONS**

**WARNING:** Improper connection of equipment grounding conductor can result in the risk of electrical shock. Equipment should be grounded while in use to protect operator from electrical shock.

- Check with a qualified electrician if grounding instructions are not understood or if in doubt as to whether the tool is properly grounded.
- This tool is equipped with an approved 3-conductor cord rated at 300V and a 3-prong grounding type plug (See Figure 4) for your protection against shock hazards.
- Grounding plug should be plugged directly into a properly installed and grounded 3-prong grounding-type receptacle, as shown (Figure 4).

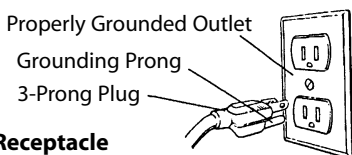

**Figure 4 – 3-Prong Receptacle**

- Do not remove or alter grounding prong in any manner. In the event of a malfunction or breakdown, grounding provides a path of least resistance for electrical shock.

**WARNING:** Do not permit fingers to touch the terminals of plug when installing or removing from outlet.

- Plug must be plugged into matching outlet that is properly installed and grounded in accordance with all local codes and ordinances. Do not modify plug provided. If it will not fit in outlet, have proper outlet installed by a qualified electrician.
- Inspect tool cords periodically, and if damaged, have repaired by an authorized service facility.
- Green (or green and yellow) conductor in cord is the grounding wire. If repair or replacement of the electric cord or plug is necessary, do not connect the green (or green and yellow) wire to a live terminal.
- Where a 2-prong wall receptacle is encountered, it must be replaced with a properly grounded 3-prong receptacle installed in accordance with National Electric Code and local codes and ordinances.

**WARNING:** This work should be performed by a qualified electrician.

- A temporary 3-prong to 2-prong grounding adapter (See Figure 5) is available for connecting plugs to a two pole outlet if it is properly grounded.

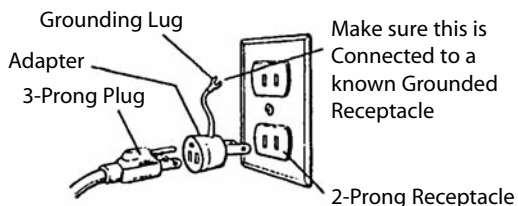

**Figure 5 – 2-Prong Receptacle with Adapter**

- Do not use a 3-prong to 2-prong grounding adapter unless permitted by local and national codes and ordinances. (A 3-prong to 2-prong grounding adapter is not permitted in Canada.) Where permitted, the rigid green tab or terminal on the side of the adapter must be securely connected to a permanent electrical ground such as a properly grounded water pipe, a properly grounded outlet box or a properly grounded wire system.

- Many cover plate screws, water pipes and outlet boxes are not properly grounded. To ensure proper ground, grounding means must be tested by a qualified electrician.

**EXTENSION CORDS**

- The use of any extension cord will cause some drop in voltage and loss of power.
- Wires of the extension cord must be of sufficient size to carry the current and maintain adequate voltage.
- Running the unit on voltages which are not within  $\pm 10\%$  of the specified voltage may cause overheating and motor burn-out.
- Use the table to determine the minimum wire size (A.W.G.) extension cord.
- Use only 3-wire extension cords having 3-prong grounding type plugs and 3-pole receptacles which accept the tool plug.
- If the extension cord is worn, cut or damaged in any way, replace it immediately.

**EXTENSION CORD LENGTH**

Wire Size .....	A.W.G.
Up to 25 ft. ....	.18
25 to 50 ft. ....	.16

**NOTE:** Using extension cords over 50 ft. long is not recommended.

**ELECTRICAL CONNECTIONS**

**WARNING:** All electrical connections must be performed by a qualified electrician. Make sure tool is off and disconnected from power source while motor is mounted, connected, reconnected or anytime wiring is inspected.

**OPERATION**

Refer to Figures 6 and 7.

**WARNING:** Operation of any power tool can result in foreign objects being thrown into eyes which can result in severe eye damage. Always wear safety goggles complying with United States ANSI Z87.1 before commencing power tool operation.

**CAUTION:** Always observe the following safety precautions:

- Whenever adjusting or replacing any parts on the tool, turn switch OFF and remove the plug from power source.
- Recheck table knobs and bolts. They must be tightened securely.
- Make sure all guards are properly attached and securely fastened.
- Make sure all moving parts are free and clear of any interference.
- Make sure all fasteners are tight and have not vibrated loose.
- With power disconnected, test operation by hand to verify clearance and adjust if necessary.
- Always wear eye protection or face shield.
- Make sure abrasive belt tracks properly. Correct tracking gives optimum performance.
- After turning switch ON, always allow belt to come up to full speed before sanding or grinding.
- Be sure motor runs clockwise on disc side. Abrasive belt must travel down.
- Avoid kickback by sanding in accordance with the directional arrows.
- Keep your hands clear of abrasive belt, disc and all moving parts.
- For optimum performance, do not stall motor or reduce speed. Do not force the work into the abrasive.
- Support workpiece with belt table when sanding with belt, with disc table when sanding with disc.

**OPERATION (CONTINUED)**

- Never push a sharp corner of workpiece rapidly against belt or disc. Abrasive backing may tear.
- Replace abrasives when they become loaded (glazed) or frayed.
- When grinding metal, move workpiece across abrasive to prevent heat build-up.
- Never attempt wet sanding. If workpiece becomes too hot to handle, cool it in water.

**MOUNT SANDER**

During operation the sander may have a tendency to slide or move about on the bench or table. It is recommended to mount the sander onto a stand or to a bench top.

**ADJUSTING BELT TABLE**

Refer to Figure 6.

**WARNING:** Disconnect sander from power source before making any adjustments.

- To adjust belt table angle, loosen the socket head bolt and adjust table to desired angle. Use a combination square to set belt table at 45° or 60° from belt platen.
- Adjust for 1/16" maximum clearance between the belt and the table.
- Secure table position by tightening bolt.

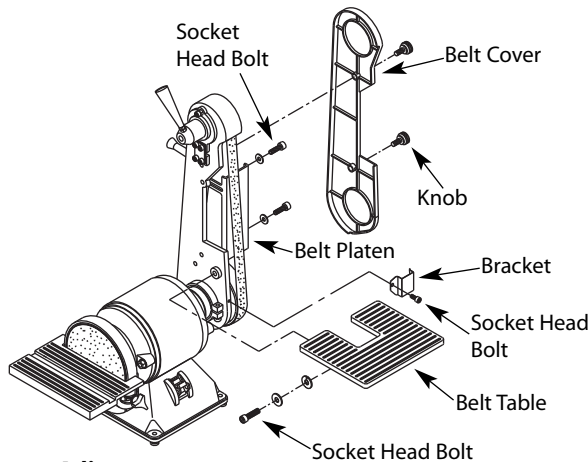

**Figure 6 - Adjustments**

**REPLACING ABRASIVE BELT**

Refer to Figures 6 and 7.

**WARNING:** Disconnect sander from power source before making any adjustments.

- Sanding belt should be replaced when worn, torn, or glazed.
- Loosen and remove two knobs from belt cover.
- Remove belt cover.
- Loosen and remove socket head bolt from bracket.
- Remove bracket.
- Loosen socket head bolt and move belt table parallel to belt.
- Release belt tension by pulling down on handle assembly. Slide old belt off the drive and tracking wheels.

**NOTE:** There may be an arrow on the inside of the belt. The arrow should point in the direction of belt travel to ensure that the splice in the belt will not come apart.

- Pull down on the handle and slide new belt over the drive and idler wheels. Center belt on wheels.
- Rotate belt by hand to check tracking. Belt should ride centered on wheels.
- If belt does not ride centered on wheels, adjust belt tracking as described in the next section.

- Replace belt cover and secure it with two knobs.
- Replace bracket and secure it with socket head bolt.
- Reset belt table to be at the desired angle, and secure it by tightening the bolt.

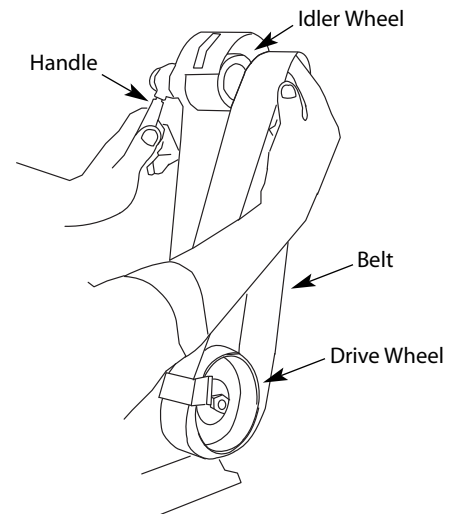
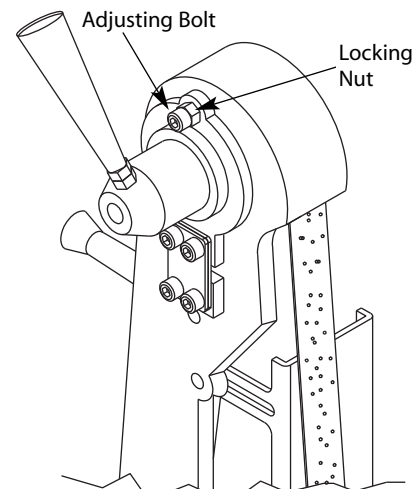

**Figure 7 - Replace Abrasive Belt**

**TRACKING ABRASIVE BELT**

Refer to Figure 8.

- Test the tracking. Plug in power cord. Turn switch ON and immediately OFF. If the abrasive belt is centered on wheels and did not move to the right or left, it is tracking properly. If the belt moved to the right or left, adjustment is necessary.
- To adjust the tracking wheel, loosen the locking nut on adjusting bolt. Use a 4mm hex wrench to turn adjusting bolt.
- If the abrasive belt moves to the left, turn the bolt counter-clockwise. If belt moves to the right, turn the bolt clockwise.
- Lock the position when the belt is tracking properly so the belt will remain centered on the wheels. Hold the position of the bolt with the 4mm hex wrench. Tighten locking nut to secure bolt position.



**Figure 8 - Tracking Belt**

**ADJUSTING BELT PLATEN**

Refer to Figure 6.

**WARNING:** Disconnect sander from power source before making any adjustments.

The platen is used to properly support the workpiece when sanding. The platen is constructed of heavy steel to provide adequate support.

**OPERATION (CONTINUED)**

Operating with the belt platen in place will allow the operator to sand or grind straight, even lines.

- The platen should be adjusted so the belt does not contact the platen until work is fed into the belt.
- To adjust belt platen, loosen and remove knobs to remove belt cover.
- Loosen socket head bolts and adjust belt platen position.
- Tighten bolts and secure platen.
- Replace belt cover and tighten knobs.

**ABRASIVE BELT FINISHING**

- The abrasive belts can be used to sand wood, deburr metal, or polish plastic.
- The belt are most efficient when used with the table.

**CONTOUR SANDING**

Refer to Figures 6 and 9.

- Belt platen can be removed for contour sanding.
- Remove knobs and belt cover.
- Remove socket head bolt and washers holding platen to belt housing. Remove belt platen.

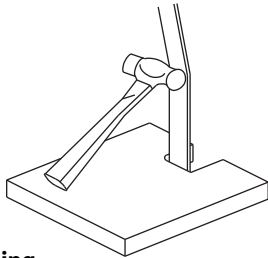

**Figure 9 - Contour Sanding**

- Replace belt cover and knobs.
- Move the workpiece against belt. Belt will follow contour.

**SHARPENING**

Refer to Figure 10.

- Adjust belt table to desired sharpening angle and tighten securely. Use belt sander to notch the back of an auxiliary piece of wood.
- Using a C-clamp, attach auxiliary piece of wood to table. It acts as a support while sharpening.
- Top edge of wood should be less than  $\frac{1}{16}$ " from abrasive belt.

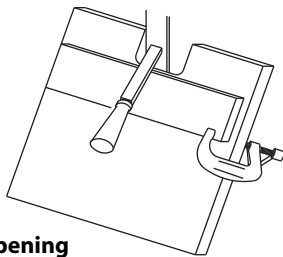

**Figure 10 - Sharpening**

**HORIZONTAL BELT SANDING**

Refer to Figures 11 and 12.

**WARNING:** Disconnect sander from power source before making any adjustments.

- The belt housing can be tilted to a horizontal position.
- Remove the belt table by removing the socket head bolt and flat washer.
- Loosen the housing lock bolt, tilt the belt housing to the horizontal position, and tighten the bolt to secure the housing position.

- The drive wheel of the belt can be used as a contact wheel for sanding curved surfaces.

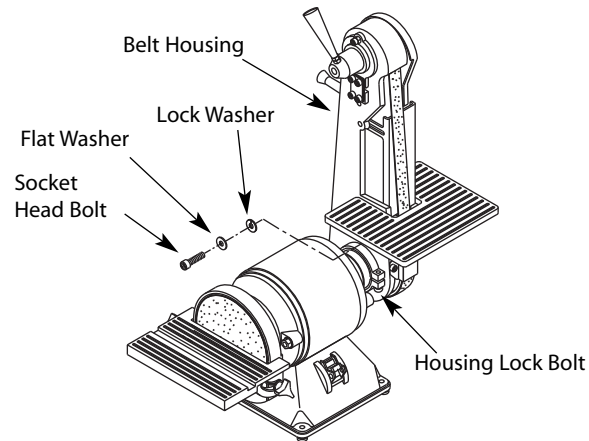

**Figure 11 - Adjusting Belt Housing**

- A work stop with nut is provided to be used when straight sanding in the horizontal position.
- Remove socket head bolt and washers holding belt table on sander. Remove belt table.
- Mount work stop to sander using the socket head bolt and washers.
- Use a combination square to adjust the work stop at 90° to the belt with a  $\frac{1}{16}$ " maximum gap between the belt and work stop.
- Use the work stop to position and stabilize workpiece. Keep end butted against work stop and move workpiece evenly across abrasive belt.

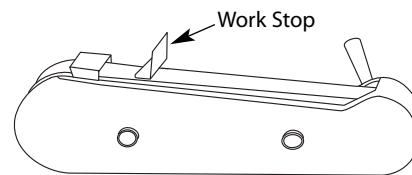

**Figure 12 - Attaching Work Stop**

- Use extra caution when finishing very thin pieces.
- Remove work stop for finishing long pieces.

**ADJUSTING DISC TABLE ANGLE**

Refer to Figure 2, page 3.

**WARNING:** Disconnect sander from power source before making any adjustments.

Disc table is adjustable from 0 to 45° for beveled work.

- To adjust the disc table, loosen the two knobs and adjust to the desired angle.
- Use the scale on disc table trunnions to set table from 0 to 45° to abrasive disc.
- When disc table is at desired angle, lock it into position by securely tightening the knobs.

**REPLACING ABRASIVE DISC**

Refer to Figure 2, page 3.

**WARNING:** Disconnect sander from power source before making any adjustments.

- Loosen and remove two knobs.
- Gently press down on disc table and slide out disc table.
- Remove old abrasive disc by peeling it from aluminum disc. Removing aluminum disc from motor shaft is not necessary.
- Clean aluminum disc if necessary. Select the proper abrasive disc and apply to aluminum disc.



**OPERATION (CONTINUED)**

- Replace disc table and tighten knobs.

**ABRASIVE DISC FINISHING**

Refer to Figure 13.

- Abrasive disc sanding is well suited for finishing small flat surfaces and convex edges.
- Move the workpiece across the down side (right) of the abrasive disc. The abrasive disc moves fastest and removes more material at the outer edge.
- For accuracy, use the miter gauge.

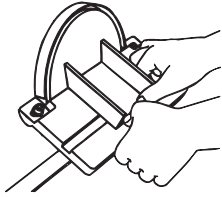

**Figure 13 - Abrasive Disc Finishing**

**USING MITER GAUGE**

Refer to Figure 14, page 10.

- The miter gauge is used only on the disc table. Use the miter gauge for securing work and holding the proper angle while disc sanding.
- Adjust the angle by repositioning the miter gauge scale and locking it into place with knob.
- Check the accuracy of the miter gauge. Use a combination square to adjust the miter gauge square to the disc. Loosen screw and reposition indicator if necessary.

**MAINTENANCE**

**WARNING:** Make certain that the unit is disconnected from power source before attempting to service or remove any component.

**CLEANING**

- Keep machine and workshop clean. Do not allow sawdust to accumulate on the tool.
- Keep wheels clean. Dirt on wheels will cause poor tracking and belt slippage.
- Operate tool with dust collector to keep dust from accumulating.

**WARNING:** After sanding wood or non-metallic material, always clean dust collector and guards of sawdust before grinding metal. Sparks could ignite debris and cause a fire.

- Be certain motor is kept clean and is frequently vacuumed free of dust.
- Use soap and water to clean painted parts, rubber parts and plastic guards.

**LUBRICATION**

- The shielded ball bearings in this tool are permanently lubricated at the factory. They require no further lubrication.
- When operation seems stiff, a light coat of paste wax applied to the belt table and disc table will make it easier to feed the work while finishing.
- Do not apply wax to the belt platen. Belt could pick up wax and deposit it on wheels causing belt to slip.

**KEEP TOOL IN REPAIR**

- If power cord is worn, cut or damaged, have it replaced immediately.
- Replace worn abrasives when needed.
- Replace any damaged or missing parts. Use parts list to order parts.
- Any attempt to repair motor may create a hazard unless repair is done by a qualified service technician.

## TROUBLESHOOTING

SYMPTOM	POSSIBLE CAUSE(S)	CORRECTIVE ACTION
Motor will not start	<ol style="list-style-type: none"> <li>1. Blown line fuse or tripped circuit breaker</li> <li>2. Low line voltage</li> <li>3. Defective switch</li> <li>4. Defective, blown capacitor</li> </ol>	<ol style="list-style-type: none"> <li>1. If fuse is blown, replace with fuse of proper size. If breaker tripped, reset it</li> <li>2. Check power supply for voltage and correct as needed</li> <li>3. Replace switch</li> <li>4. Replace capacitor</li> </ol>
Motor will not start; fuses blown or circuit breakers tripped	<ol style="list-style-type: none"> <li>1. Overloading due to binding</li> <li>2. Defective plug</li> <li>3. Defective cord</li> <li>4. Defective switch</li> </ol>	<ol style="list-style-type: none"> <li>1. Clean around wheels and shaft and/or replace bearings</li> <li>2. Replace plug</li> <li>3. Replace cord</li> <li>4. Replace switch</li> </ol>
Motor fails to develop full power (power output of motor decreases rapidly with decrease in voltage at motor terminals)	<ol style="list-style-type: none"> <li>1. Power line overloaded with lights, appliances and other motors</li> <li>2. Undersized wires or circuits too long</li> <li>3. General overloading of power company's facilities</li> </ol>	<ol style="list-style-type: none"> <li>1. Reduce load on power line</li> <li>2. Increase wire sizes, or reduce length of wiring</li> <li>3. Request a voltage check from power company</li> </ol>
Motor overheats	Motor overloaded	Reduce load on motor.
Motor stalls (resulting in blown fuses or tripped circuit breakers)	<ol style="list-style-type: none"> <li>1. Short circuit in motor or loose connections</li> <li>2. Low voltage</li> <li>3. Motor wired for different line voltage</li> <li>4. Incorrect fuses or circuit breakers in power line</li> <li>5. Motor overloaded</li> </ol>	<ol style="list-style-type: none"> <li>1. Inspect connections in motor for loose or shorted terminals or worn insulation on lead wires</li> <li>2. Correct the low line voltage conditions</li> <li>3. Rewire motor as per line voltage</li> <li>4. Install correct fuses or circuit breakers</li> <li>5. Reduce load on motor</li> </ol>
Machine slows down while operating	Applying too much pressure to workpiece	Ease up on pressure
Abrasive belt runs off top wheel	Not tracking properly	See operation section "Tracking Abrasive Belt"



---

# NOTES

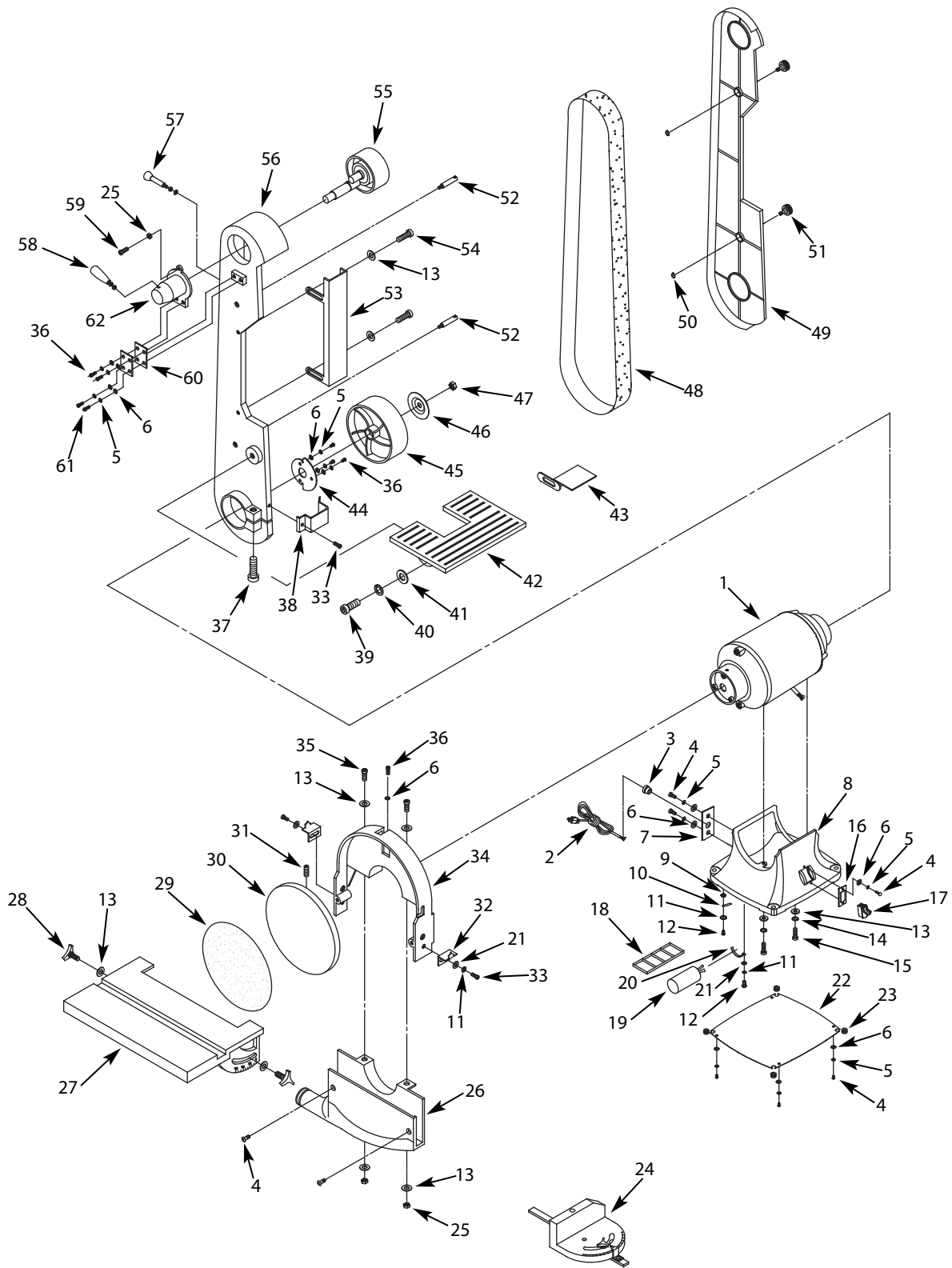

Figure 14 - Replacement Parts Illustration for Sander

## REPLACEMENT PARTS LIST FOR SANDER

Ref. No.	Description	Part No.	Qty.	Ref. No.	Description	Part No.	Qty.
1	Motor Assembly	30638.00	1	34	Disc Guard	24704.00	1
2	Line Cord	00067.00	1	35	6-1.0 x 20mm Socket Head Bolt	*	2
3	Strain Relief	30639.00	1	36	5-0.8 x 10mm Socket Head Bolt	*	6
4	5-0.8 x 8mm Pan Head Screw	*	10	37	8-1.25 x 30mm Socket Head Bolt	*	1
5	5mm Lock Washer	*	15	38	Lower Belt Guard	24708.00	1
6	5mm Flat Washer	*	16	39	10-1.5 x 25mm Socket Head Bolt	01002.00	1
7	Strain Relief Plate	30640.00	1	40	10mm Lock Washer	*	1
8	Base	N/A	1	41	10mm Flat Washer	*	1
9	4mm Serrated Washer	05156.00	1	42	Belt Table	04662.00	1
10	Grounding Pin	30641.00	1	43	Work Stop	04660.00	1
11	4mm Lock Washer	*	4	44	Stop Bracket	30643.00	1
12	4-0.7 x 8mm Pan Head Screw	*	2	45	Drive Wheel	04661.00	1
13	6mm Flat Washer	*	10	46	Wheel Flange	24709.00	1
14	6mm Lock Washer	*	2	47	12-1.75mm Hex Nut	*	1
15	6-1.0 x 16mm Socket Head Bolt	*	2	48	Abrasive Belt	08901.00	1
16	Switch Plate	30642.00	1	49	Belt Cover	24711.00	1
17	Rocker Switch with Key	08066.00	1	50	3AMI-7 Retaining Ring	24683.00	2
18	Capacitor Base	N/A	1	51	Knob	24684.00	2
19	Capacitor	30648.00	1	52	Stand Off	24710.00	2
20	Clamp	30649.00	1	53	Belt Platen	16632.00	1
21	4mm Flat Washer	*	3	54	6-1.0 x 12mm Socket Head Bolt	*	2
22	Base Cover	N/A	1	55	Tracking Wheel Assembly	30644.00	1
23	Base Bumper	04051.00	4	56	Belt Housing	24712.00	1
24	Miter Gauge Assembly	07800.01	1	57	Horizontal Stop	30645.00	1
25	6-1.0mm Hex Nut	*	3	58	Handle Assembly	30646.00	1
26	Dust Collection Chute	24706.00	1	59	6-1.0 x 25mm Socket Head Bolt	*	1
27	Disc Table	30663.00	1	60	Spring Plate	03327.01	2
28	Knob	04658.00	2	61	5-0.8 x 16mm Socket Head Bolt	*	2
29	Abrasive Disc	03126.00	1	62	Tension Spring Assembly	30647.00	1
30	Aluminum Disc	04657.00	1	Δ	Operator's Manual	31694.00	1
31	8-1.25 x 10mm Set Screw	07202.00	1		<b>Recommended Accessories</b>		
32	Pointer	24705.00	2	Δ	Heavy Duty Floor Stand	70102	1
33	4-0.7 x 8mm Socket Head Bolt	*	3				

Δ Not Shown.

\* Standard hardware item available locally.

N/A Not available as replacement part.

## WARRANTY

Palmgren warrants their products to be free of defects in material or workmanship. This warranty does not cover defects due directly or indirectly to misuse, abuse, normal wear and tear, failure to properly maintain the product, heated, ground or otherwise altered, or used for a purpose other than that for which it was intended. The warranty does not cover expendable and/or wear parts (i.e. v-belts, coated screws, abrasives), damage to tools arising from alteration, abuse or use other than their intended purpose, packing and freight. The duration of this warranty is expressly limited to one year parts and labor, unless otherwise noted below beginning from the date of delivery to the original user. The Palmgren products carry the following warranties on parts with a 1 year warranty on labor:

- USA Machine vises – Lifetime
- IQ Machine vises – Lifetime
- Bench vises – Lifetime
- Positioning tables – Lifetime
- Bench grinders & buffers – 3 years
- Tapping machines – 2 years
- Drilling machines – 2 years
- Finishing machines – 2 years
- Band saws – 2 years
- Work stands – 2 years
- Arbor presses – 2 years
- Metal framing equipment – 2 years
- Accessories – 1 year

The obligation of Palmgren is limited solely to the repair or replacement, at our option, at its factory or authorized repair agent of any part that should prove deficient. Purchaser must lubricate and maintain the product under normal operating conditions at all times. Prior to operation

become familiar with product and the included materials, i.e. warnings, cautions and manuals. **Failure to follow these instructions will void the warranty.**

This warranty is the purchaser's exclusive remedy against Palmgren for any deficiency in its products. Under no circumstances is Palmgren liable for any direct, indirect, incidental, special or consequential damages including lost profits in any way related to the use or inability to use our products. This warranty gives you specific legal rights which may vary from state to state.

### SERVICE & REPAIR

1. If a Palmgren product requires a repair or warranty service **DO NOT** return the product to the place of purchase.
2. All warranty related work must be evaluated and approved by Palmgren.
3. Prior to returning any item the user must obtain factory approval and a valid RGA number.
4. For instructions and RGA number call toll free (800) 621-6145.

