

Serial number 4009 or greater

Parts Page Reorder No. PD14.06  
Effective February 2014

# 36"x60" Metal Capture Downdraft Table

*Tool Manual - Safety, Operation and Maintenance*

**SAVE THIS DOCUMENT, EDUCATE ALL PERSONNEL**

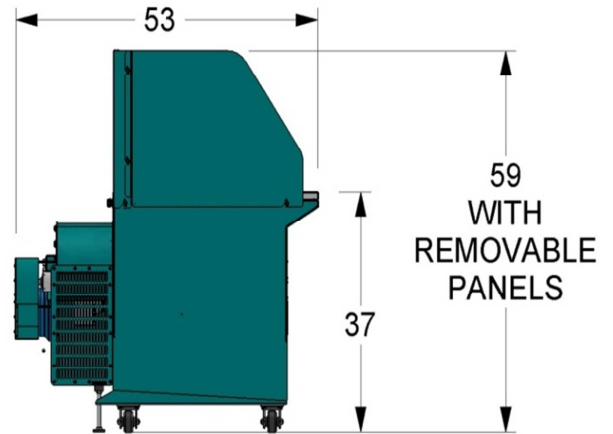
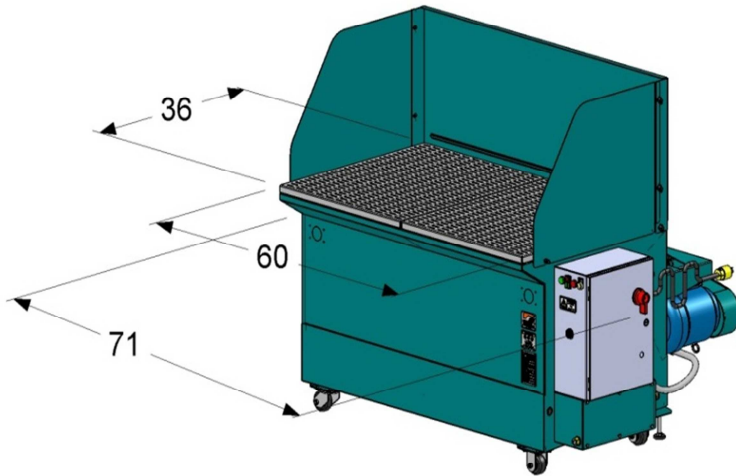

Model Number	Motor hp	Voltage	Frequency	FLA	Phase	Air Flow	Sound Level	Working Area Width	Working Area Length	Height	Exhaust	Shipping Weight
64372	3	380	50 Hz	4.3	3	1800 CFM	85 dB(A)	36"	60"	37"	Down	700 lbs
64373	3	380	50 Hz	4.3	3	1800 CFM	85 dB(A)	36"	60"	37"	Up	700 lbs
64374	3	380	50 Hz	4.3	3	1800 CFM	85 dB(A)	36"	60"	37"	Side	700 lbs
64400	3	230	60 Hz	7.2	3	1800 CFM	85 dB(A)	36"	60"	37"	Down	700 lbs
64401	3	460	60 Hz	3.6	3	1800 CFM	85 dB(A)	36"	60"	37"	Down	700 lbs
64402	3	230	60 Hz	7.2	3	1800 CFM	85 dB(A)	36"	60"	37"	Up	700 lbs
64403	3	460	60 Hz	3.6	3	1800 CFM	85 dB(A)	36"	60"	37"	Up	700 lbs
64404	3	230	60 Hz	7.2	3	1800 CFM	85 dB(A)	36"	60"	37"	Side	700 lbs
64405	3	460	60 Hz	3.6	3	1800 CFM	85 dB(A)	36"	60"	37"	Side	700 lbs

# CONTENTS

<b>MODEL SPECIFICATIONS</b> .....	<b>COVER</b>
<b>DESCRIPTION</b> .....	<b>3</b>
<b>INTENDED USE</b> .....	<b>3</b>
<b>FORESEEABLE MISUSE</b> .....	<b>3</b>
<b>IMPORTANT SAFETY INSTRUCTIONS</b> .....	<b>4</b>
<b>INSTRUCTIONS FOR USE</b> .....	<b>7</b>
Machine Setup .....	<b>7</b>
Shield Installation .....	<b>6</b>
Machine Operation.....	<b>6</b>
Maintenance.....	<b>6</b>
Maintenance Schedule.....	<b>17</b>
Trouble Shooting.....	<b>18</b>
<b>DIMENSIONS</b> .....	<b>24</b>
<b>PARTS</b> .....	<b>25</b>
<b>SCHEMATIC</b> .....	<b>28</b>
<b>WARRANTY</b> .....	<b>32</b>

## **DESCRIPTION**

The Metal Capture Downdraft Table is a worktable with a downdraft of air through the work surface used to collect metal dust from grinding or sanding operations. Downdraft air flow is created by an electric motor driven impeller. The dust is separated from the airflow by entrainment in water droplets in a turbulent air and water interface and then settles in the base of the worktable. Cleaned air exits through the impeller exhaust.

## **INTENDED USE**

The Metal Capture Downdraft Table is for industrial indoor use by trained operators who are grinding or sanding either aluminum or titanium or steel work pieces. It is to be used with a pneumatic abrasive tool controlled by the Metal Capture Downdraft Table's interlocking system to prevent abrasive tool operation until the downdraft air flow is established.

Set-up, maintenance and troubleshooting must be done by trained industrial technicians who have read and understood this manual.

## **FORESEEABLE MISUSE**

Set up or troubleshooting by unqualified technicians or without consulting this manual.

Use outdoors or in wet conditions.

Use by untrained or unauthorized operators.

Grinding unapproved materials.

Collecting chemical fumes.

Bypassing the pneumatic interlock and grinding on the work surface when the machine is off.

Neglecting maintenance.

Allowing fugitive dust to accumulate more than 1/32" thick.

Blocking exhaust or impeding vents.

# IMPORTANT SAFETY INSTRUCTIONS

READ ALL PARTS OF THIS MANUAL CAREFULLY BEFORE USE

KEEP FOR FUTURE REFERENCE

## Definitions

**DANGER** - Indicates a hazardous situation that, if not avoided, will result in death or serious injury.

**WARNING** - Indicates a hazardous situation that, if not avoided, could result in death or serious injury.

**CAUTION** - Indicates a hazardous situation that, if not avoided, could result in minor or moderate injury.

## Machine set up

1. **WARNING:** Death or serious injury can occur from crushing if machine tips or falls when lifting machine from shipping pallet. Center of mass location is found on dimensions diagram on page 24. Lift truck forks must be inserted minimum 12 inches (300mm) past the center of mass.
2. **WARNING:** Death or serious injury can occur from crushing if machine tips or falls when installing and leveling casters. Lift machine maximum 12 inches from ground to allow caster installation or leveling. Support machine with stable blocking to prevent tipping.
3. **WARNING:** Death or serious injury can occur from electrocution or arc flash if incorrect connections are made when connecting electric power. Connections must be made by trained industrial technicians or electricians only.

4. **WARNING:** Death or serious injury can occur from electrocution or arc flash if incorrect connections are made when connecting electric power. Connections must be made by trained industrial technicians or electricians only.
5. **WARNING:** Death or serious injury can occur from electrocution or arc flash if electric cord is damaged. Do not pull cord or use cord to move machine.
6. **CAUTION:** Injury from slip or fall is possible if water overflows from machine during unattended filling. Do not leave machine unattended when filling.
7. **CAUTION:** Injury from impact is possible from air hose or fitting failure when connecting compressed air lines.
  - a. Do not exceed 90 PSI.
  - b. Fitting must be prevented from rotating when connecting air line. Use wrench on fittings.
  - c. Connections must be made by trained industrial technicians.

### Shield Installation

1. **CAUTION:** Injury from crushing or cutting is possible if hands or fingers are caught under work surface or shields during installation. Keep hands and fingers clear during installation of work surfaces or shields.

### Machine Operation

1. **WARNING:** Death or serious injury can occur from dust deflagration if hazardous amounts of fugitive dust are allowed to accumulate. Stop operation and clean machine and surrounding areas if dust layer exceeds 1/32".
2. **WARNING:** Death or serious injury can occur from dust deflagration if unapproved materials are collected, e.g., not approved for collecting magnesium dust.
3. **WARNING:** Death or serious injury can occur from dust deflagration if more than one approved materials is collected without first cleaning the machine out, e.g., grinding aluminum and then steel without first cleaning out the aluminum from the machine.
4. **WARNING:** Death or serious injury can occur from hydrogen gas deflagration if vents are blocked and hydrogen gas is trapped. Keep minimum 3 feet of clearance from the back and sides of the machine.

5. **CAUTION:** Injury from cutting is possible if abrasive pneumatic tool starts unexpectedly. Only use tools with a safety throttle lever.
6. **CAUTION:** Permanent hearing loss is possible if exposure to sound exceeds the limits of Federal, State or local statutes, ordinances and/or regulations. Wear hearing protection.
7. **CAUTION:** Eye injury from grinding particles is possible when using abrasive power tools. Eye protection conforming to ANSI Z87.1 must be worn at all times.

## Maintenance

1. **WARNING:** Death or serious injury can occur from deflagration or explosion if waste grinding sludge is not mixed with inert material in a 5:1 ratio for storage in open container. Sludge can release flammable hydrogen gas.
2. **WARNING:** Drowning or serious injury can occur from falling into machine. Use caution when accessing inside of machine.
3. **CAUTION:** Injury from slip or fall is possible if floor is wet.
4. **CAUTION:** Injury from entanglement is possible if machine is operated without v-belt guard. Always install guards before use.

## Troubleshooting

1. **DANGER:** Death or serious injury will occur from electrocution or arc flash after direct or indirect contact with live parts. Disconnect electric power before accessing controls.

# INSTRUCTIONS FOR USE – Machine Setup

The 64400 Series Metal Capture Dwindraft Table will be pallet shipped to its destination. The following details will describe the steps required for initial machine setup before operation. Read through the entire setup procedure to understand its requirements before trying to run machine.

**Warning:**

*Failure to follow the required steps for machine setup may result in damage to machine or personal injury.*

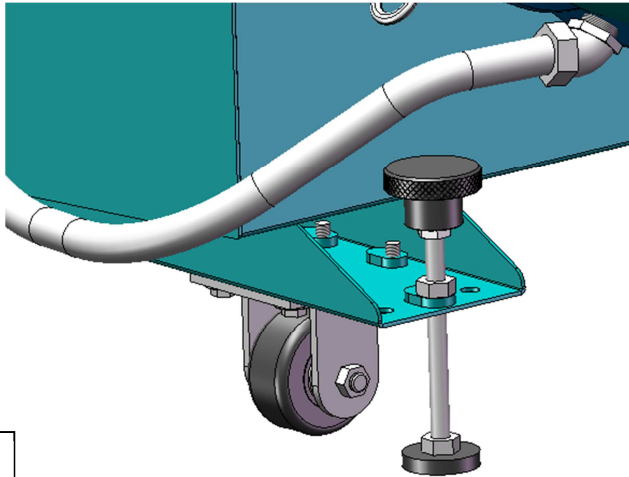
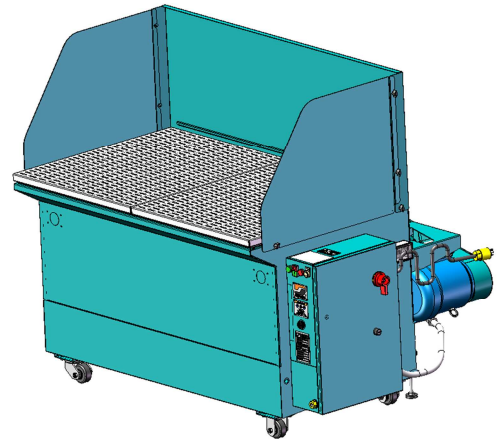

1

Before removing your machine from the pallet, locate the casters and related hardware provided. Installing these casters can be done as you are removing the machine from the palette with a fork truck. Fork from the back of the table (the motor side). Qty 2 swivel casters and qty 2 rigid casters are provided for mounting. Mount two rigid casters at one end and two swivel casters at opposite end. Also, install the locking posts as shown.

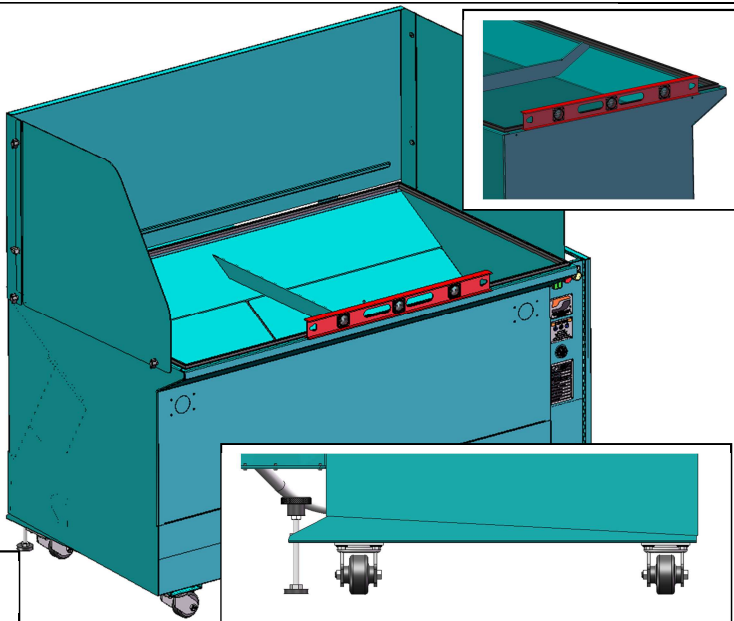

2

The next step is to level the machine. Having the machine level is crucial for the auto-fill sensor to operate properly, maintaining critical water level for proper filtration. After determining machine location and with work surfaces removed, utilize a level off the rigid top edges of the machine. Block and shim off the flat of the caster legs located at the base of the assembly to provide a level machine on all four sides. Machine to be no more than 1/16" out of level over any 3-foot span.

# INSTRUCTIONS FOR USE - Machine Setup

3

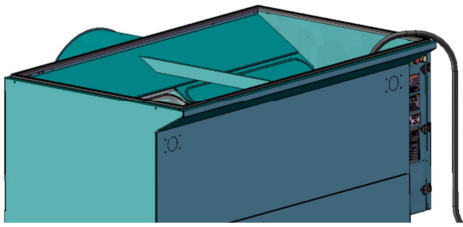

You must now fill your tank to the proper start up water level. For initial setup, manually filling the tank is suggested. Use a garden hose from your water source and drop to the bottom of the tank before beginning to fill.

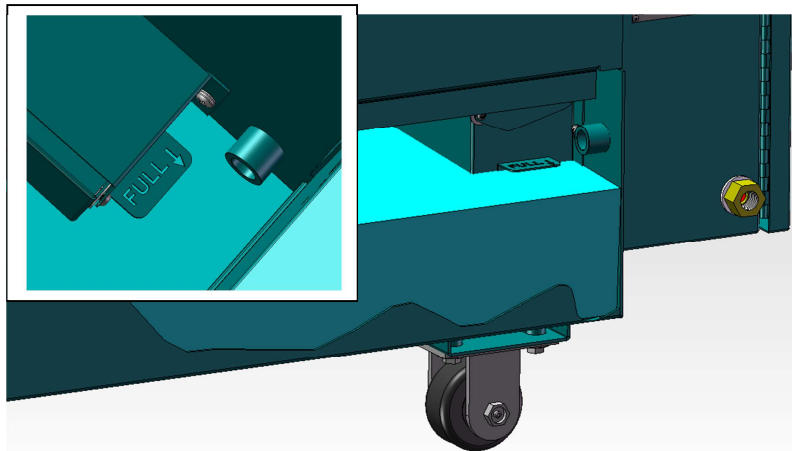

There is a "Full" tab located on the isolation chamber, which indicates the proper fill level for the machine in the "OFF" position. Continue filling the machine until the water is approximately 1/4" short from the bottom surface of the fill tab as shown in Detail A.

Do not allow the water to fill higher than this full tab. If level is greater than height of tab, proceed to remove water from machine until desired height is reached as indicated above. **CAUTION:** If machine is overfilled past the fill tab by more than 3/8", water will begin to exit from the emergency overflow and on to the shop floor.

Once the desired level has been reached, remove hose from tank and place your work surfaces into position.

Note: The machine's auto-fill system will bring the water level up to exact run height (Full), after the machine's disconnect is turned to the "On" position as described in Step 8 of the **Machine Setup**. Ensure that the water in main collection tank is at the proper height before beginning operation of machine.

Emergency Overflow

1/4"

Detail A

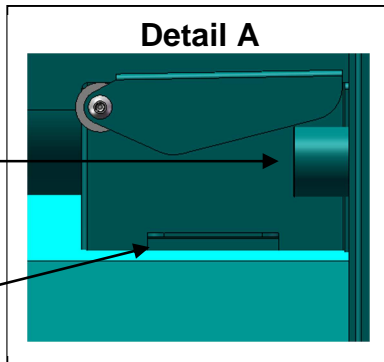

4

5

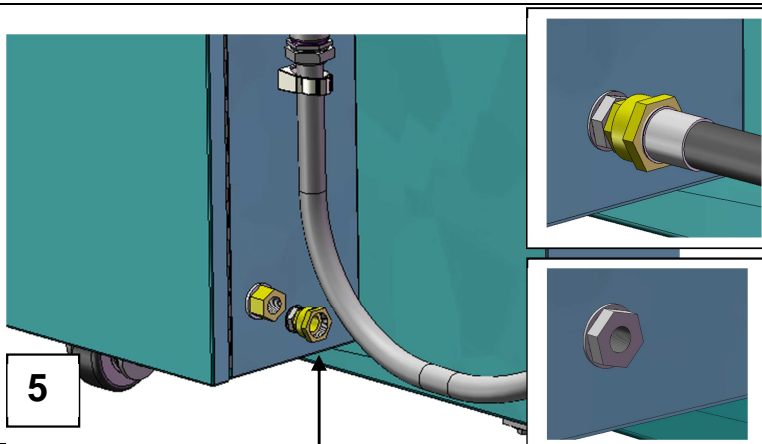

The machine is equipped with a self-filling water level system, which requires a constant water supply. The machine comes with a 3/4" female garden hose swivel connect located at the rear of the machine or you can remove the brass garden hose swivel connect and use the 1/4" NPT female bulkhead fitting for providing a water source.



# INSTRUCTIONS FOR USE - Machine Setup

64400: NEMA L15-20 250 VAC 20A  
64401: NEMA L16-20 480 VAC 20A  
64402: NEMA L15-20 250 VAC 20A  
64403: NEMA L16-20 480 VAC 20A  
64404: NEMA L15-20 250 VAC 20A  
64405: NEMA L16-20 480 VAC 20A

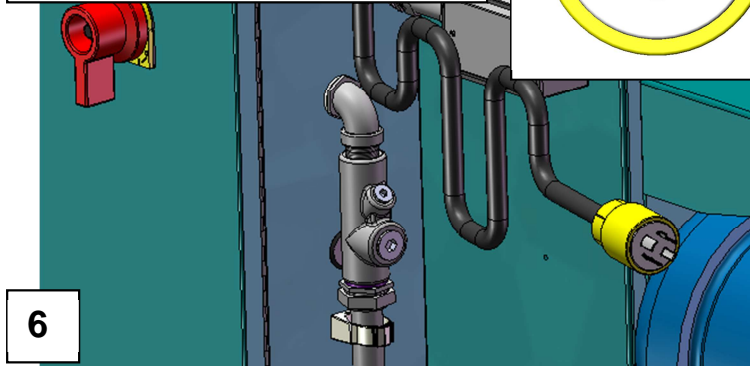
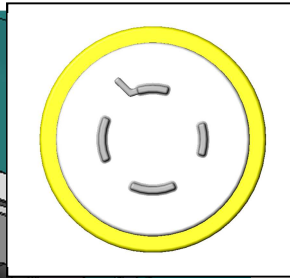

Next you will need to provide a power source for your machine. Refer to the parts page, as the model number will be used for determining the voltage rating for your specific machine.

**Warning:**

DO NOT attempt to wire the machine for any other voltage other than that stated for your model. There are internal components to the control box that are voltage specific and failure to provide proper voltage can cause damage to your machine and could cause personal injury.

**Model: 64400, NEMA L15-20 shown**

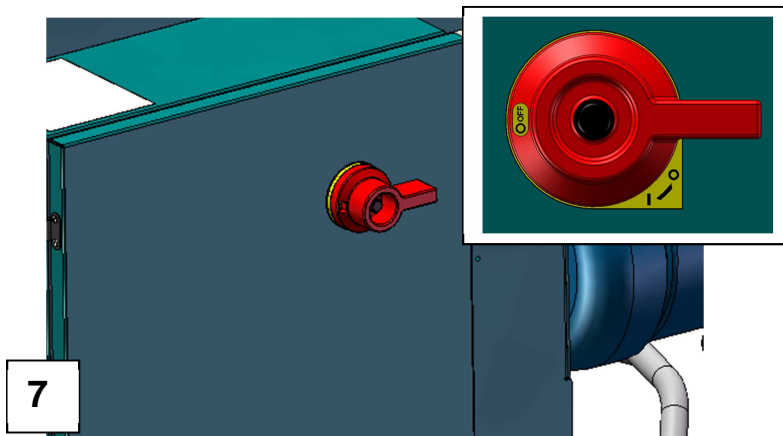

Before plugging in your machine, be sure that the lockout disconnect is in the "Off" position.

**Note:**

The disconnect is used as a lockout mechanism. For any maintenance required inside the control box, the disconnect will need to be in the off position to open the access door. If the disconnect is in the on position, the access door will remain locked.

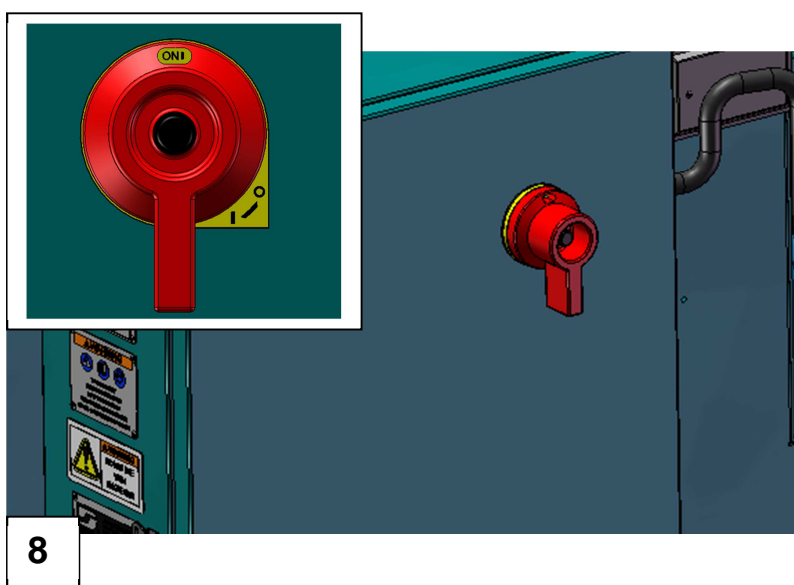

After plugging your machine in, proceed to move the lockout disconnect to the "On" position, providing power to the machine and sensory controls. Once power has been provided, the green pilot light will start a flashing sequence for a 15 second set-up stage. The auto-fill system will take over after the set-up stage is complete and bring the machine's water level to the correct height before allowing the operator to turn on the machine. At the time the green pilot light glows solid, the machine is then ready to start. Whenever the auto-fill operates the green pilot light will flash.

# INSTRUCTIONS FOR USE - Machine Setup

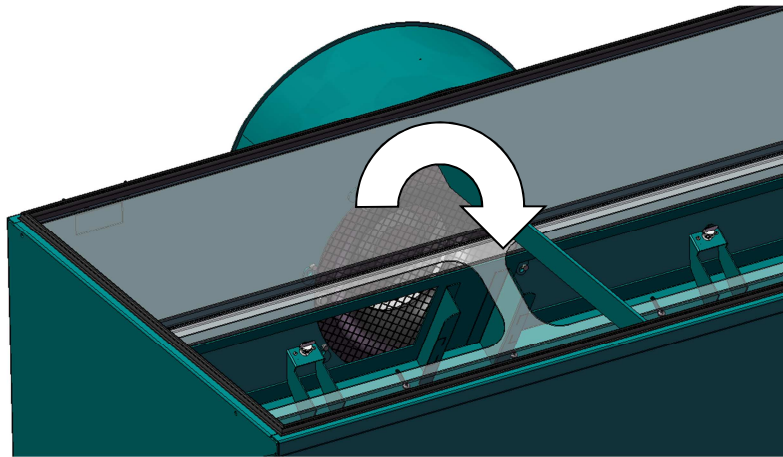

9

**WARNING:** It is also important to recognize when wiring your machine, proper rotation of the impeller is essential for operation. Before turning machine on, remove the access covers and mist traps from the machine, giving access to a view of the inlet ring and impeller assembly. Start machine temporarily to confirm direction of rotation. Impeller should rotate in a clockwise direction viewed from the front of the machine as shown. If impeller is rotating counter-clockwise, unplug power and interchange any two of the main power leads from the 3 phase supply.

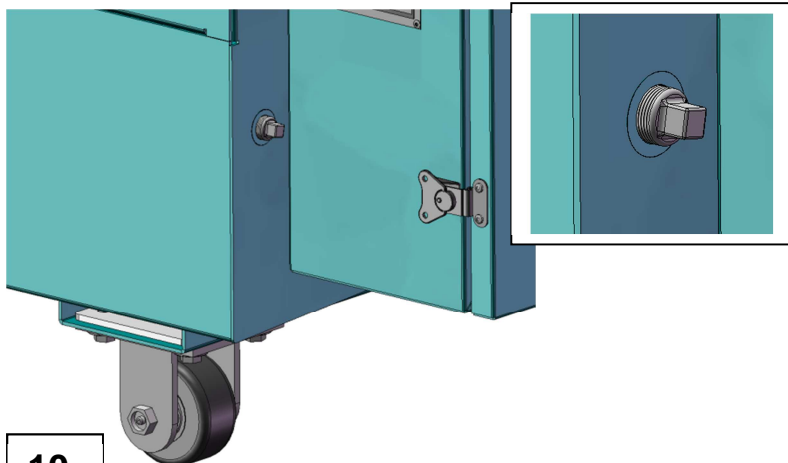

10

Located at the front of the machine is an emergency overflow outlet. The machine is shipped with a plug which must be removed before operating. The plug should only be used for transporting a water filled machine from work center to work center, preventing splash out during transfer.

The 1/2" female NPT emergency outlet provided was designed to allow water to drain from tank if desired run level was to become too high. A hose to a local floor drain is recommended.

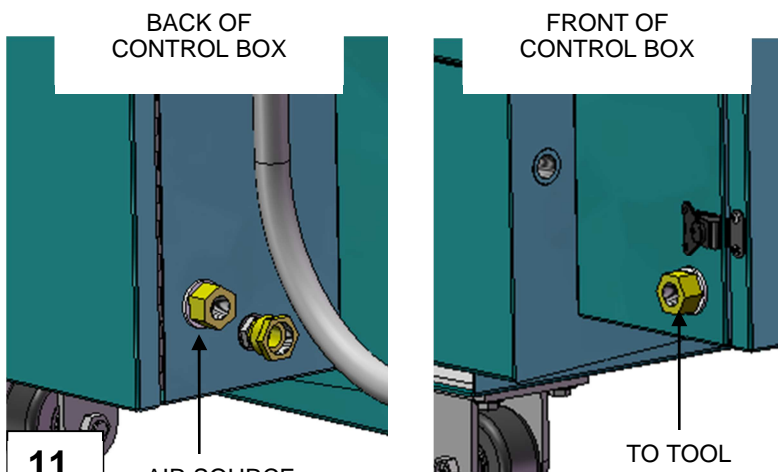

11

The machine is provided with a pneumatic interlock. The interlock will only provide air to the working tool after the machine has reached optimal run speed.

Air source: 1/2" NPT fitting  
To Tool: 1/2" NPT fitting

Maximum air pressure: 90 psi

Maximum airflow: 95 SCFM

# INSTRUCTIONS FOR USE - Shield Installation

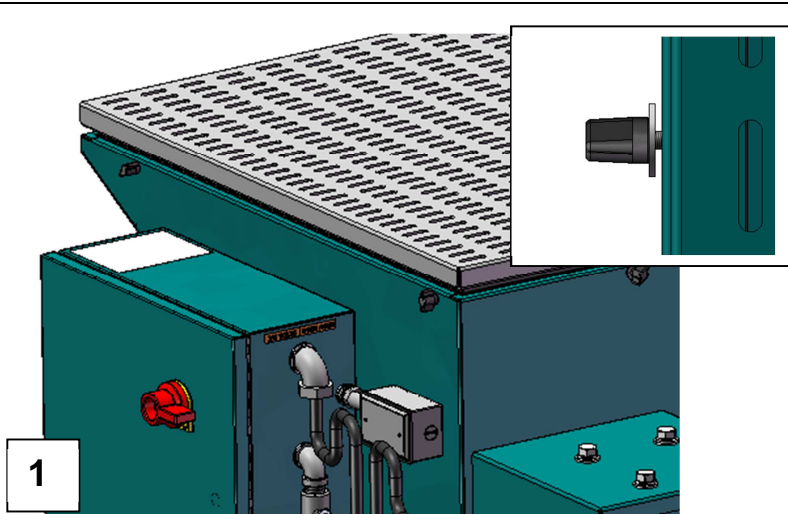

To begin installing the machine's shielding assembly, screw qty 6 locking knobs into the threaded holes located around the perimeter of the main tank. The two rear knobs will have a steel washer for locking down the rear panel. Leave a 1/8" gap as shown at all 6 locations, to allow for the installing of the rear and side panels.

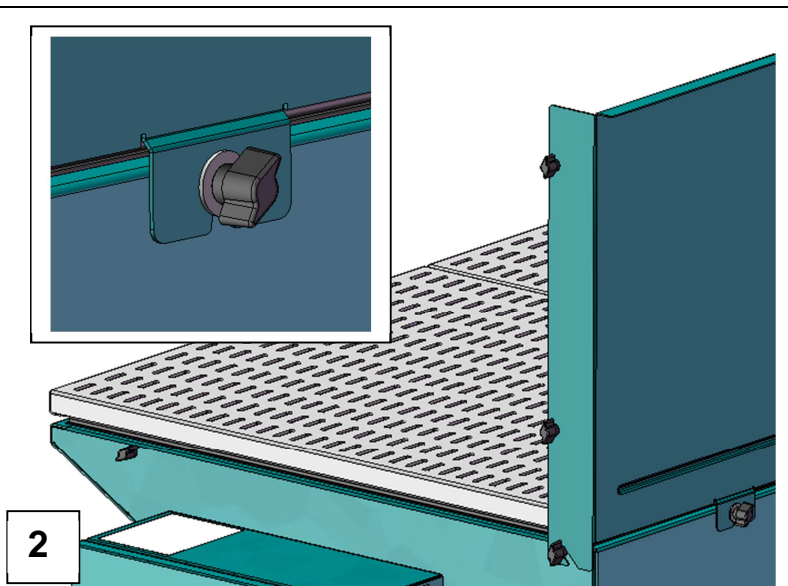

With two people supporting the rear panel, slide the rear panel into place first. Be sure that the washer remains on the outside of the sheet metal tab as shown. Snug up the four knobs associated to this rear panel but do not tighten down completely at this time.

Add the remaining 4 lockdown knobs to the pre-threaded holes located on the return legs of the rear panel. These knobs will be used for locking down the side panels. Remember to leave a 1/8" gap for sliding the side panels into place.

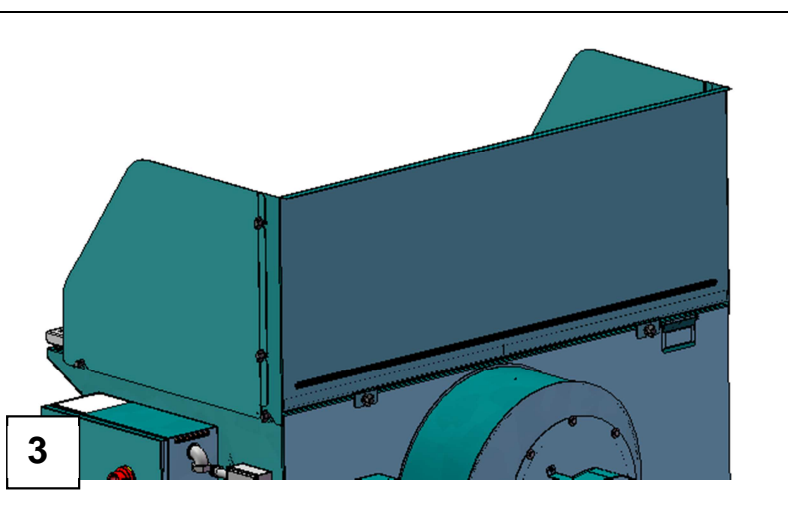

Slide both left and right panels into place and lock down until hand tight.

Continue by hand tightening all lock down knobs down.

Note:  
The work surfaces can be removed with shielding in place. Disassembly is not required for maintenance.

# INSTRUCTIONS FOR USE - Machine Operation



1

"Start" Button

Once the green pilot light glows constant, you can then turn on the machine.

Press and release the "Start" button. The machines impeller will reach its optimal operating speed in approximately 5 seconds and air filtration will begin. You can now begin to grind your work piece.

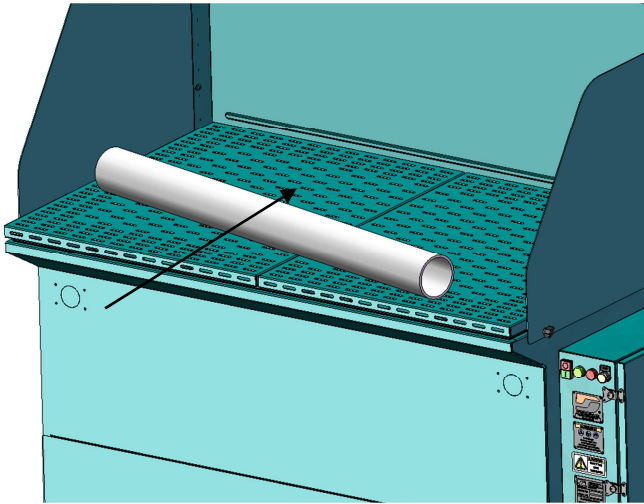

2

The direction of grind is very important to maximum dust collection and reduce fugitive dust. Be sure to manipulate both your work piece and tool to insure that the table is capturing the highest percentage of dust.

Always direct grind towards shielding for maximum capture rate.

**NOTE:** The machine is provided with a pneumatic interlock. The interlock will only provide air to the working tool after the machine has reached optimal run speed.

# INSTRUCTIONS FOR USE - Maintenance

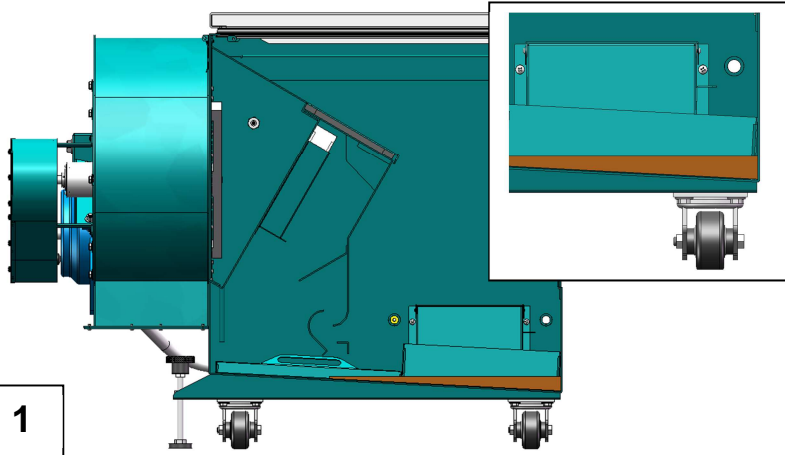
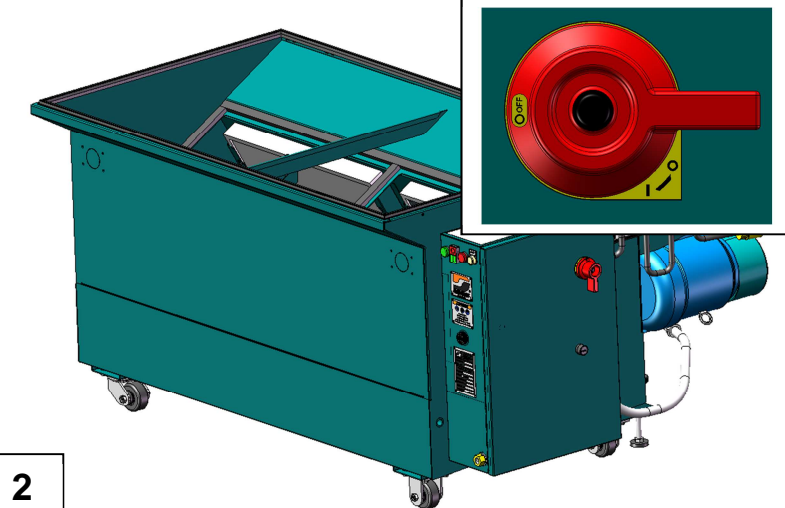
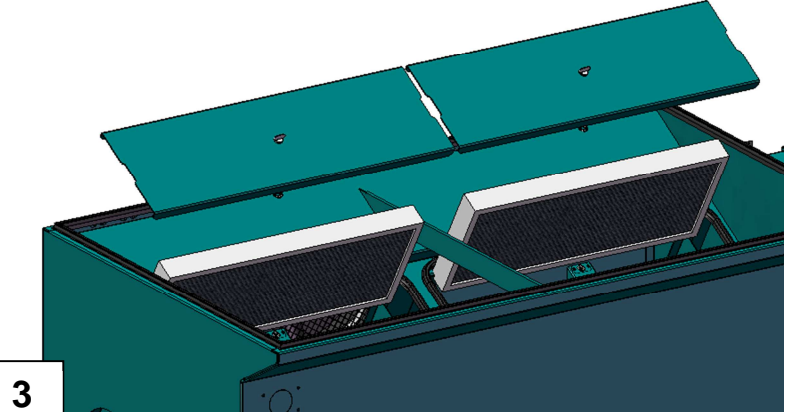
 <p>1</p>	<p>After machine use, sludge will collect in the clean-out pans located at the bottom of the tank. After each day of use, sludge should be removed and transported in a covered, vented steel container for storage or disposal in accordance with federal, state and local regulations-Sludge containing aluminum should be mixed with an inert material (dry clay) in the ratio of 5 parts inert material to 1 part sludge.</p>
 <p>2</p>	<p>Before beginning any maintenance to your machine, first make sure the lockout disconnect is in the off position.</p> <p>Remove both work surfaces to gain access to the interior of the tank.</p>
 <p>3</p>	<p>Continue by removing both access panels and mist traps.</p> <p>After 30 days of use, remove mist traps from Metal Capture Table, rinse with clean water to remove any trapped sludge or debris. Once clean, re-install mist traps before operation of machine. Inspect mist traps for signs of corrosion or damage. Replace if any corrosion or damage is found.</p>

# INSTRUCTIONS FOR USE - Maintenance

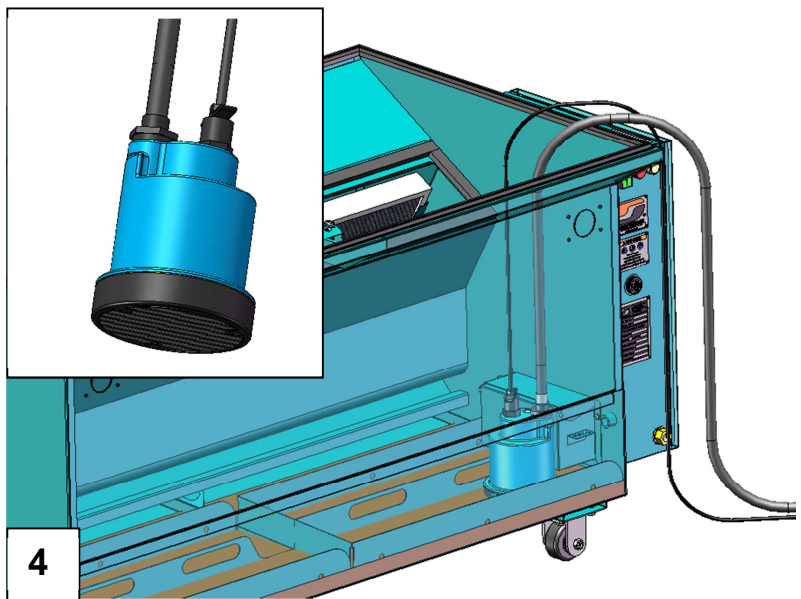

Use a utility pump to drain the water out of the machine.

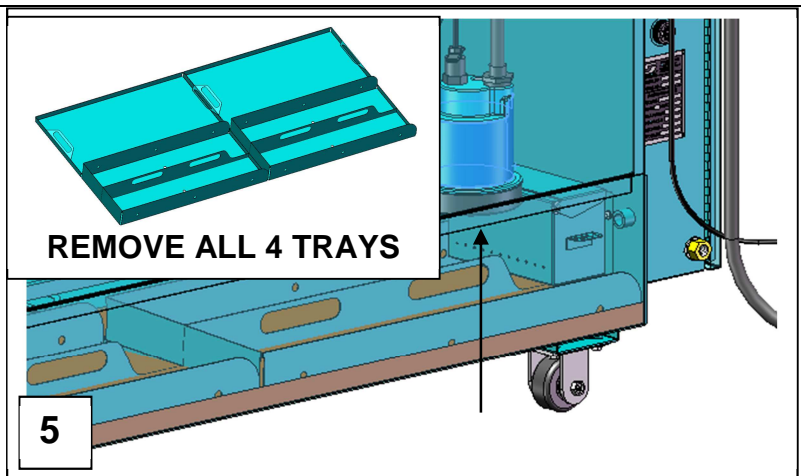

After draining all water, remove the pump. Continue by removing the collection trays and use a small flat non-sparking shovel to remove the remaining sludge from both the tank and collection trays.

Adhere to local codes to properly dispose contaminated liquids/sludge.

Hose clean and re-install mist traps and collection trays back into machine and lock down access panels.

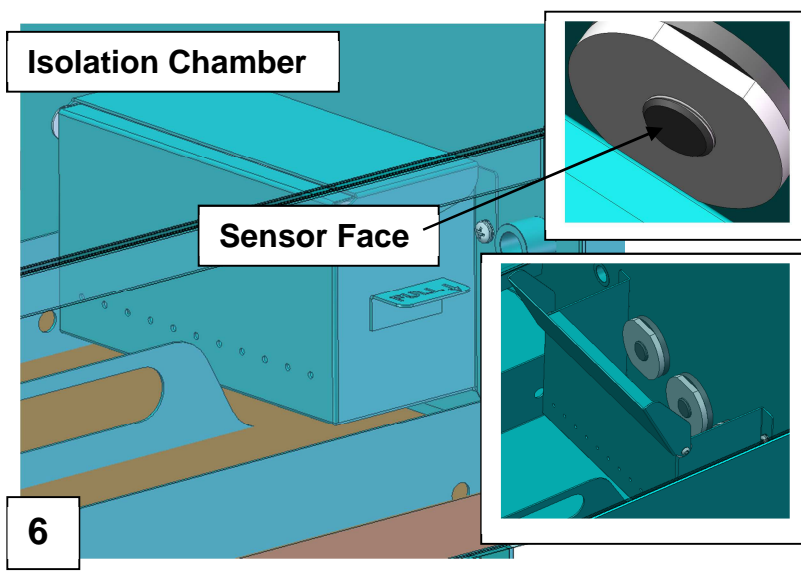

Keeping the liquid level sensors clean from sludge and debris is very important in maintaining the machine's proper water level both in "On" and "Off" mode.

Located in the isolation chamber, open lid and use a damp cloth to clean the face of each sensor after each day of use, removing any grind build-up or foreign debris that has accumulated.

# INSTRUCTIONS FOR USE - Maintenance

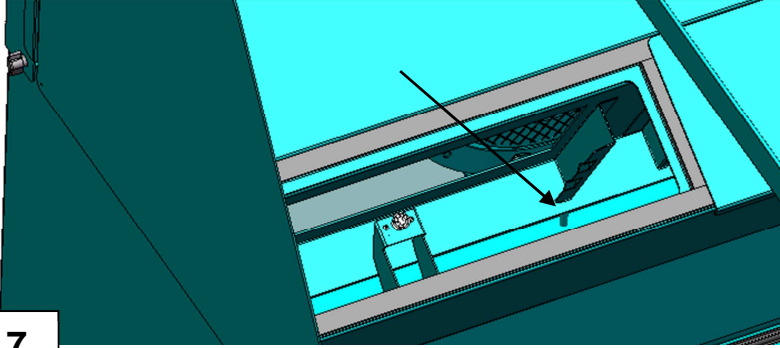

7

In addition to the base of the tank and the collection trays, you must also make sure that the drain tube is clear of any debris as well. Remove access panel and mist trap to locate and allow access to the drain tube as shown at the arrow in the detail.

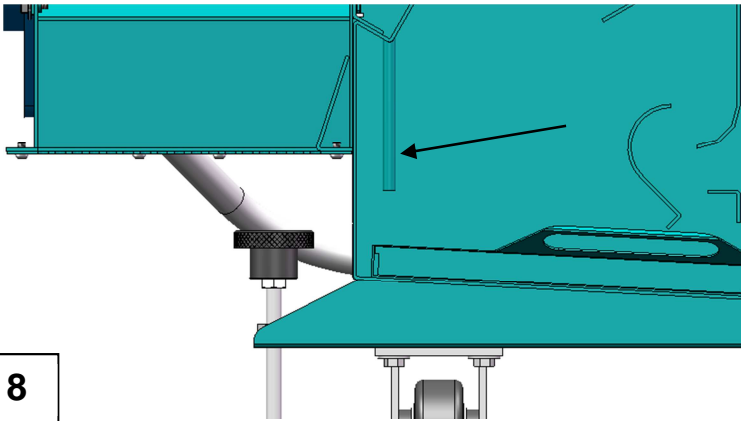

8

As shown in this section view, the drain tube is located at the rear of the assembly.

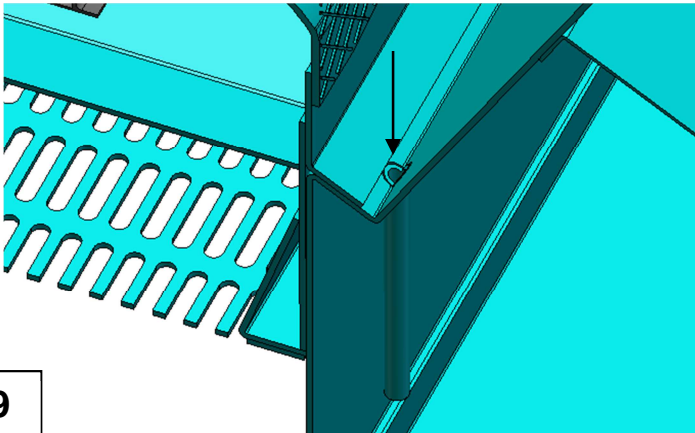

9

Use a rigid tool of choice to slide through the ID of the tube, making sure there is no build-up of any kind.

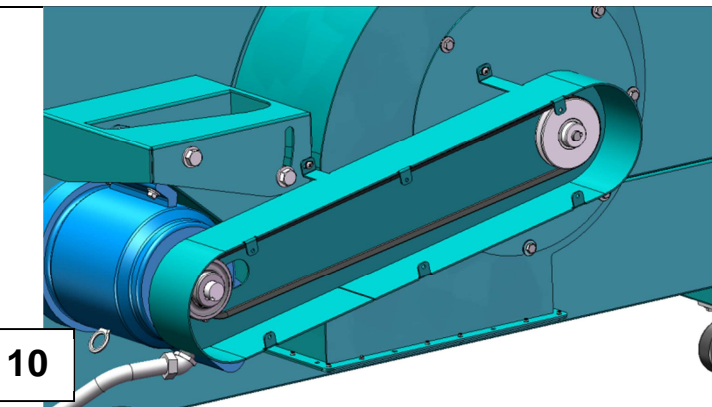

10

After 180 days of use inspect the V-belt and replace if worn or damaged.

# INSTRUCTIONS FOR USE - Maintenance

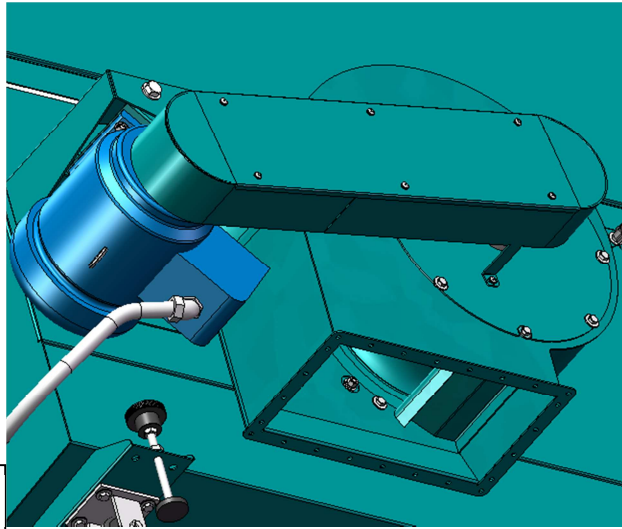

11

After each day of use, inspect the Metal Capture Table exhaust vent, internal and external surfaces and surrounding work area for any fugitive dust accumulation exceeding 1/32" thickness- remove with non-sparking, conductive dustpans and natural bristle brushes.

Inspect exhaust for accumulated dust. Remove grate and clean if dust exceeds 1/32".

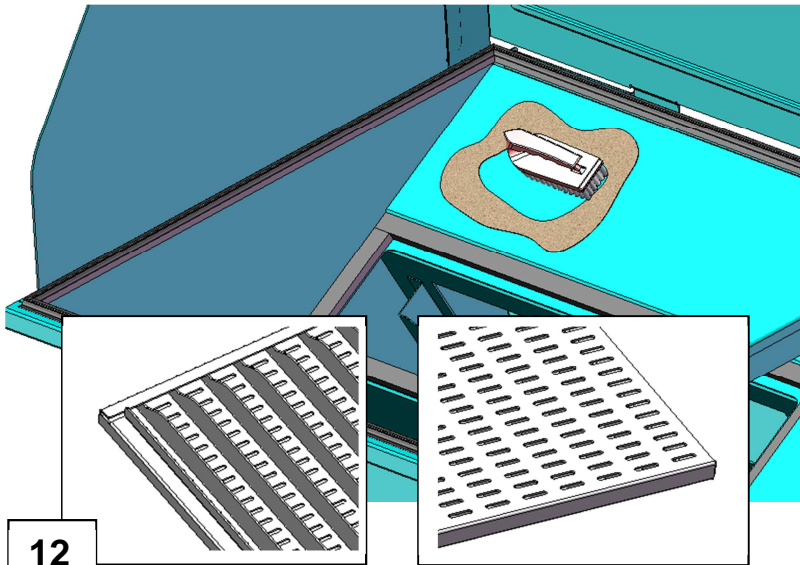

12

Continue by inspecting the interior and exterior of the assembly. Clean as necessary, based of 1/32" max accumulation.

Be sure to inspect and clean work surfaces top and bottom as well.

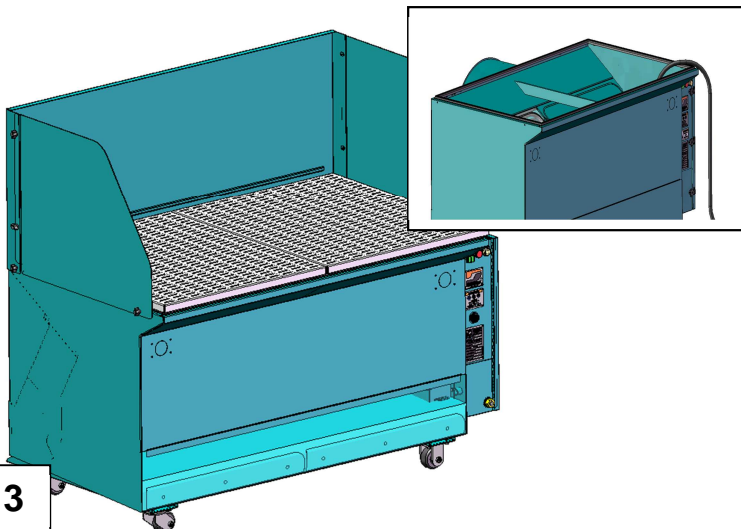

13

After every 30 days of use, replace the water in the collection tank with clean water- Dispose of used water in accordance with federal, state and local regulations.

Follow the **Machine Setup** for re-filling your machine and start-up.



# INSTRUCTIONS FOR USE – Maintenance Schedule

Maintenance Schedule	Daily	Every 30 Days of use	Every 180 Days of use
Check Water Level	✓		
Remove sludge from collection tank	✓		
Remove any accumulated dust	✓		
Rinse mist traps with clean water	✓		
Replace water in collection tank		✓	
Inspect mist traps		✓	
Inspect V-Belt			✓
Clean Sensor Faces	✓		

**Check Water Level:**

Insure that water in main collection tank is at the proper height before beginning operation of machine.

**Remove sludge from Collection Tank:**

Sludge should be transported in a covered, vented steel container for storage or disposal in accordance with federal, state and local regulations- sludge containing aluminum should be mixed with inert material (dry clay) in the ratio 5 parts inert material to 1 part sludge.

**Remove any accumulated dust:**

Inspect the Metal Capture Station or Table exhaust vent, internal and external surfaces and surrounding work area for any fugitive dust accumulation exceeding 1/32” thickness- remove with non-sparking, conductive dustpans and natural bristle brushes.

**Rinse Mist traps with clean water:**

Remove mist traps from Metal Capture Station or Table and rinse with clean water to remove any trapped sludge or debris. Once clean re-install mist traps before operation of machine.

**Replace water in collection tank:**

Replace the water in the collection tank with clean water-Dispose of used water in accordance with federal, state and local regulations.

**Inspect Mist Traps:**

Inspect mist traps for signs of corrosion or damage. Replace if any corrosion or damage is found.

**Inspect V-Belt:**

Inspect V-Belt and replace if worn or damaged

**Clean Sensor Faces:**

Located in the isolation chamber, open lid and use a damp cloth to clean the face of each sensor, removing any grind build-up or foreign debris that has accumulated.

# INSTRUCTIONS FOR USE - Trouble Shooting

## Power

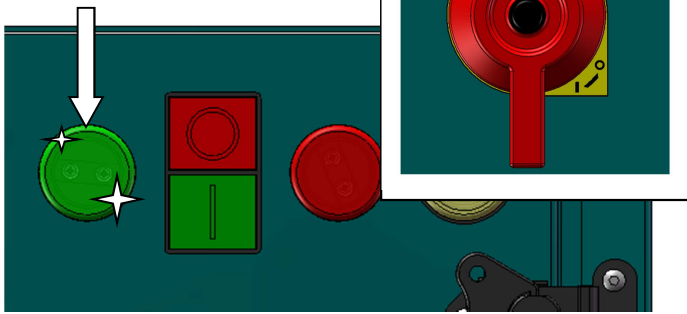

### **Ready to Start:**

After plugging your machine in, proceed to move the lockout disconnect lever to the on position, providing power to the machine and sensory controls. Once power has been provided, the green pilot light will start a flashing sequence for a 15 second setup stage. Be aware, you will not be able to power up the machine during this flashing stage. Once the green pilot light illuminates solid, you can then power up the machine.

## Fault

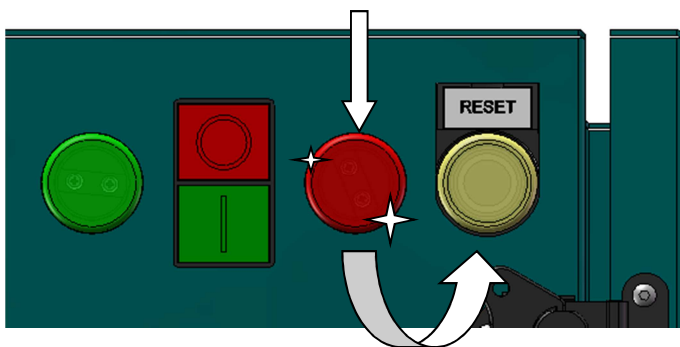

The red pilot light is used to signal different fault messages, depending upon its flash pattern.

### **A) Flash Pattern 1:**

#### **“ON” 3 seconds, “Off” 3 second:**

During the above **Ready to Start** mode, the machine will allow the solenoid valve to open and fill the machine for a maximum of 10-minutes. If the **Ready to Start** sensor is not met in this 10-minute window, the machine will go into lockdown and will require a reset. Press the reset button briefly and then release. At this time, the machine will go back to the **Ready to Start** mode as indicated above.

### **B) Flash Pattern 2:**

#### **“ON” 1 second, “Off” 1 second:**

Indicates that the machine has shut down. The water level is not sufficient in the run mode and the auto-fill has attempted to reach proper water level but has failed.

*The machine will now require a reset. Press the reset button briefly and then release. At this time, the machine will go back to the **Ready to Start** mode as indicated above.*

### **C) Flash Pattern 3:**

#### **“ON” ½ second. “ Off” ½ second:**

Indicates that the machine has shut down. The water level is too high during run mode. The machines water level should be manually emptied back down to the proper depth indicated by the full tab. Clean off all liquid level sensors to ensure proper read of water level.



## WARNING

If reset is required, proper water height is not being sensed. Check to make sure that water source is providing sufficient supply. Water level sensors may also require cleaning. Refer to manual on proper care and maintenance of machine.  
If machine continues to shut down, consult factory for further assistance.

**Dynabrade: 1-800-828-7333**

# INSTRUCTIONS FOR USE - Trouble Shooting

Fault

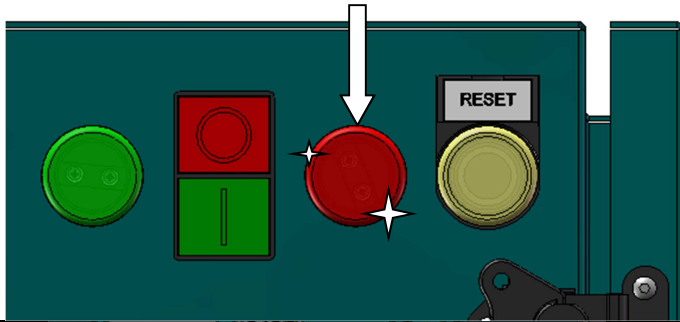

## E) Flash Pattern 4:

**“ON” 5 second, “Off” 1 second:**

A motor overload will shut down the system and trigger this flashing sequence. At this time, a qualified electrician should determine why the motor overload was tripped and use of the machine should be stopped until the cause of overload is determined.

If your flash pattern indicates that there has been a motor overload, a reset button has been provided to bring your overload back to start mode.

Possible Causes of motor overload:

- **Too frequent start-stop:** Limit start interval to once every 5 minutes
- **Motor/Fan Bearing Failure**
- **Low water level:** Check auto level system
- **Impeller rotation Backwards:** Should rotate clockwise from front of machine

## Too frequent Start-Stop:

Starting and stopping your machine multiple times in under a 5min window of time is generally the main cause for a system motor overload trip. Limit the start-stop of your machine in this range, as the overload requires a cool down period after each start.

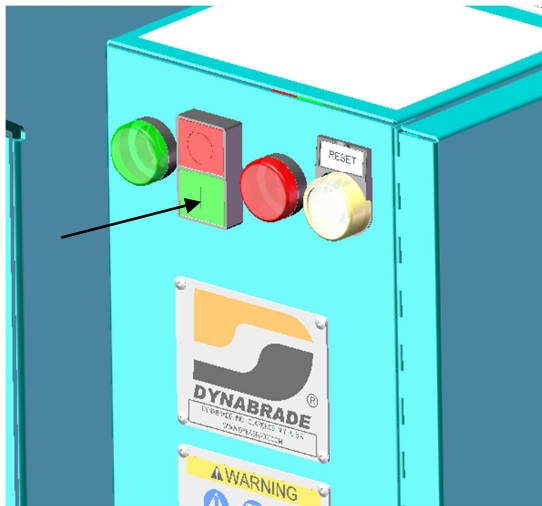
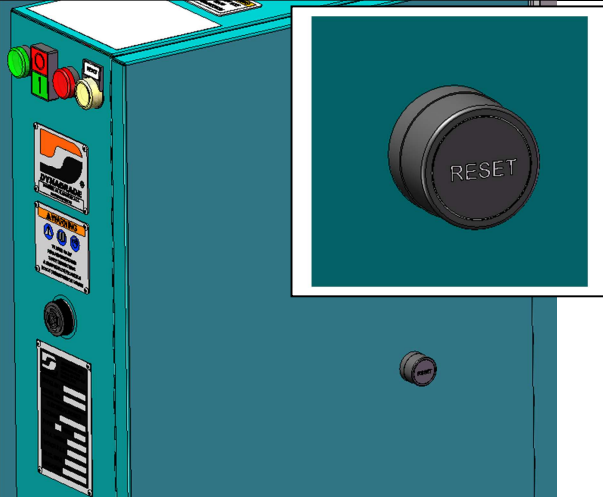

# INSTRUCTIONS FOR USE - Trouble Shooting

## Metal Capture System Water Level Sensor Function and Adjustment

### 1. Water Level Sensors

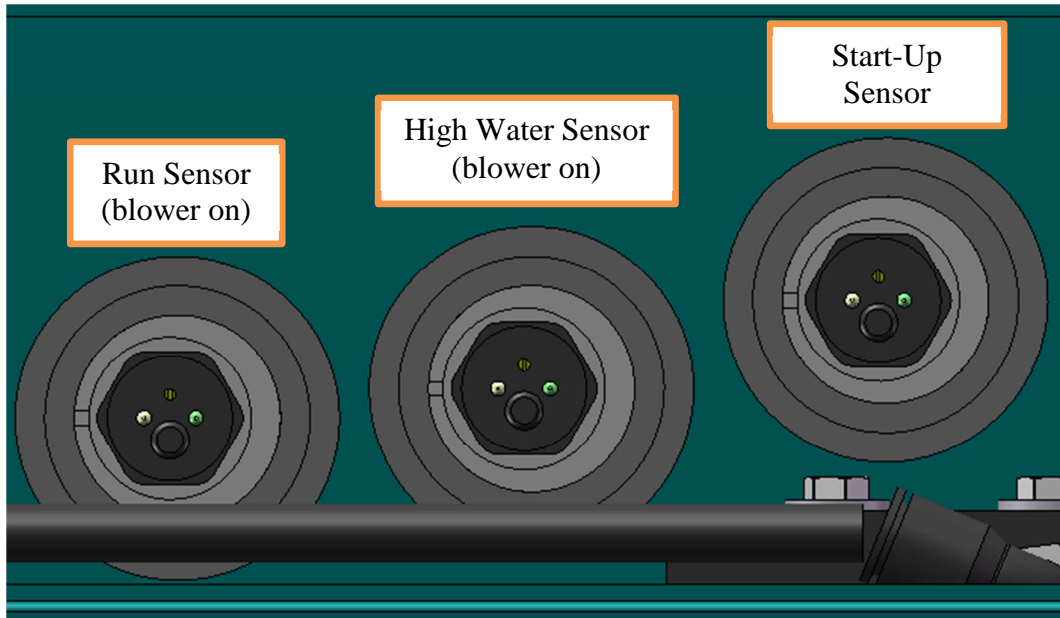

### 2. Sensor Function

Water level with the blower off should be in the center of the Start-Up Sensor. Water level with the blower on should be in the center of the Run Sensor. Excessive water level is indicated by the High Water Sensor. Sensors will signal the control system to add water or to shut down the Metal Capture system and indicate a fault.

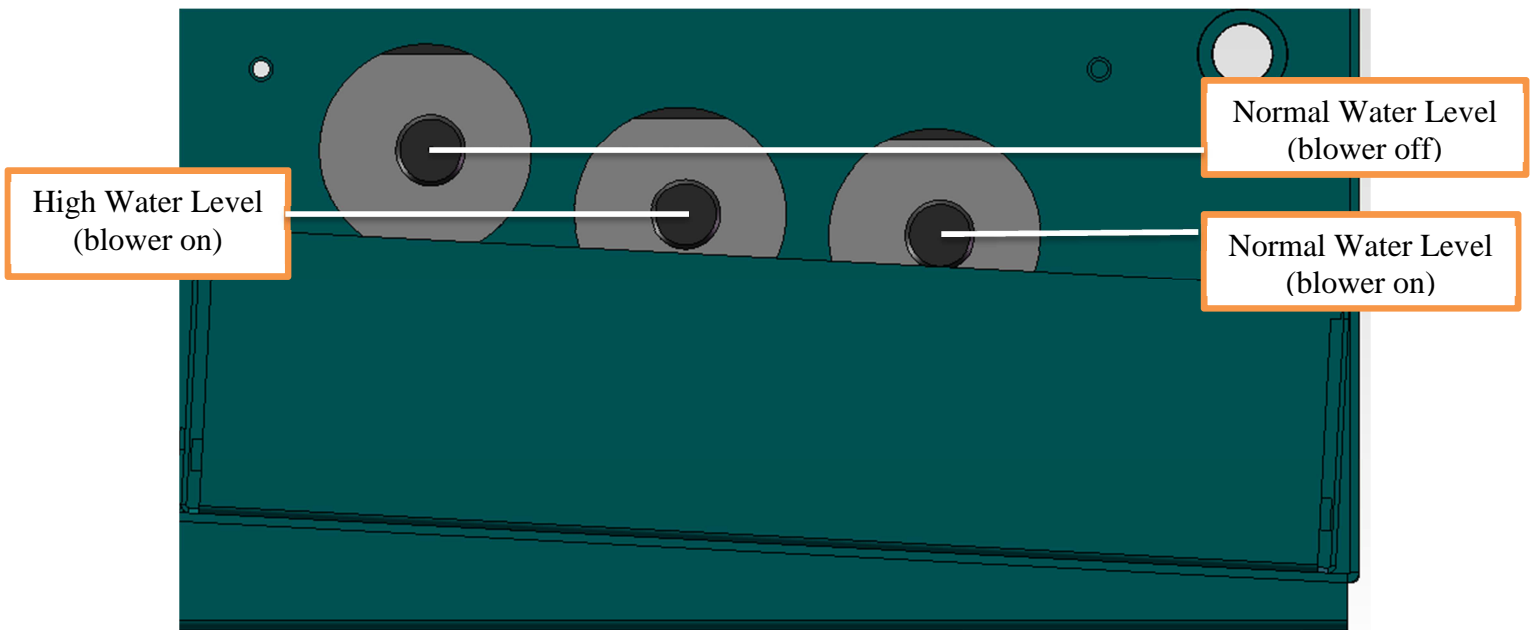

# INSTRUCTIONS FOR USE - Trouble Shooting

## 3. Sensor Adjustment

The water level sensors' sensitivity is adjusted to signal the presence of water.

- Whenever power is connected to the system, the green LEDs on all the sensors will be illuminated.
- Yellow LED on indicates water is sensed.
- Turn 1/16" slotted brass adjustment screw clockwise to increase sensitivity (lower water level) and counter clockwise to decrease sensitivity (raise water level).

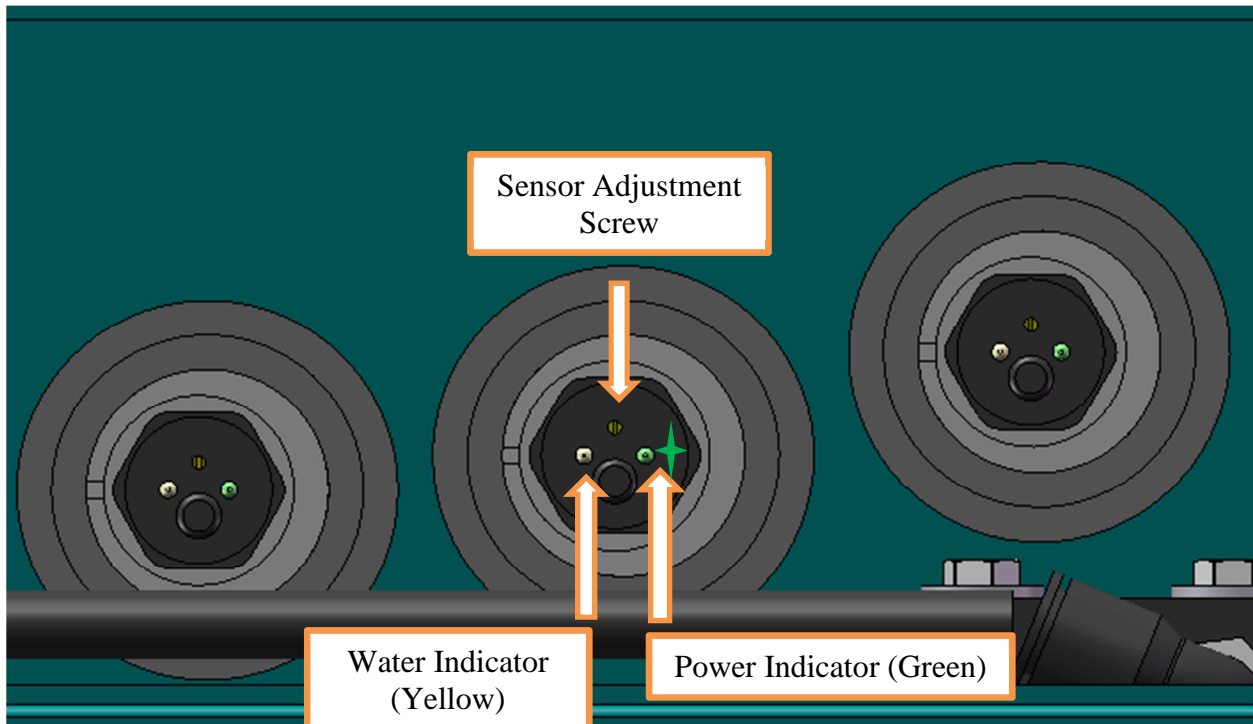

- Adjustment screw driver (1/16").

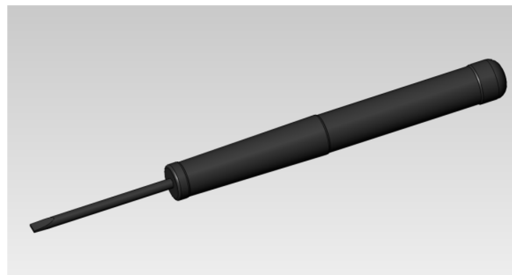

# INSTRUCTIONS FOR USE - Trouble Shooting

## Sensor adjustment con't

- If the Water Indicator is illuminated (A), adjust the sensitivity screw counter-clockwise until the Water Indicator LED turns off (B). Continue by turning the Sensor Adjustment Screw one full rotation in the clockwise direction (C). Water Indicator LED will now be illuminated.

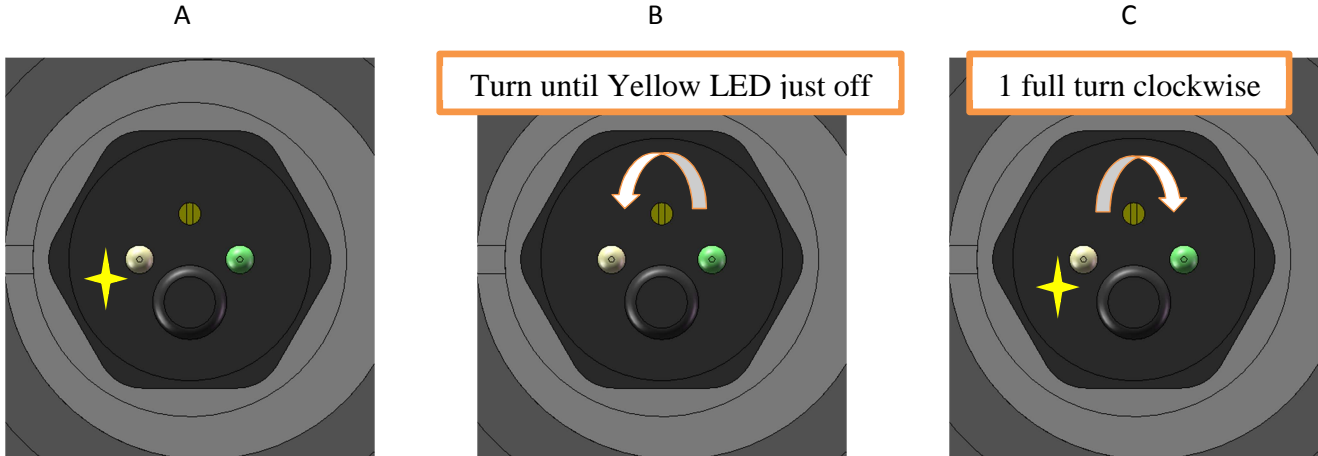

- If the Water Indicator is not illuminated (A), adjust the Sensor Adjustment Screw clockwise until the Water Indicator LED turns on (B). Continue by turning the Sensor Adjustment Screw one full rotation in the clockwise direction (C). Water Indicator LED will remain illuminated.

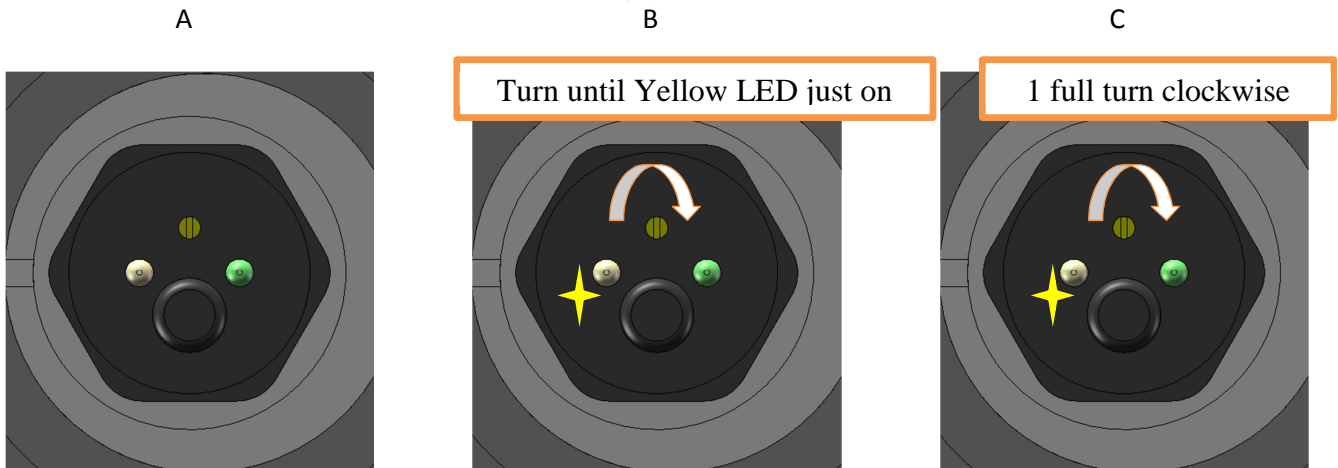

# INSTRUCTIONS FOR USE - Trouble Shooting

## 4. Sensor Height Adjustment

- Sensor height can be adjusted 1/8" by rotating the sensor bulkhead.
- Locator slot indicates mid-height when horizontal.
- With power disconnected and water drained below bulkhead level, loosen bulkhead nut and rotate bulkhead to increase or decrease sensor height. Re-tighten nut, add water and check for leaks before re-connecting power.

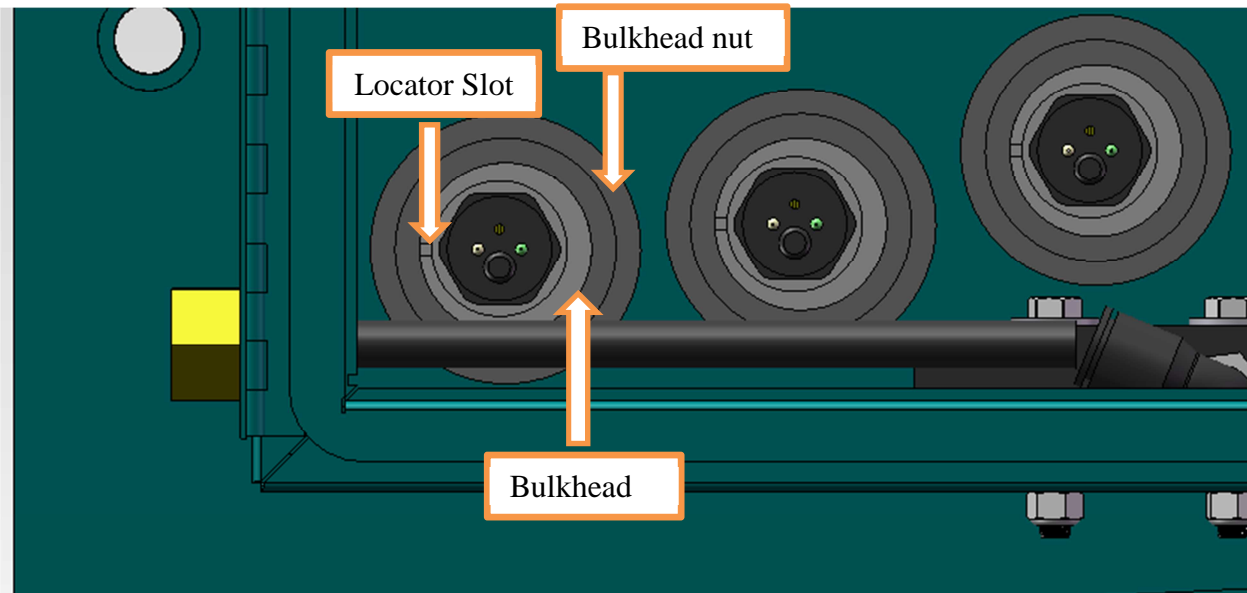

# DIMENSIONS

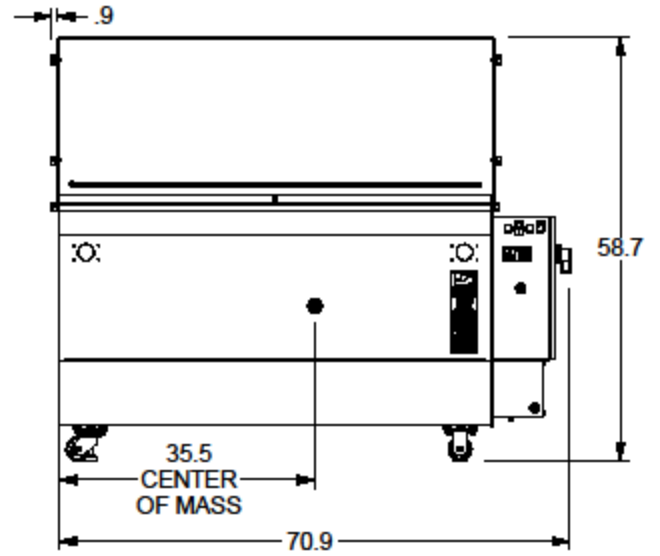
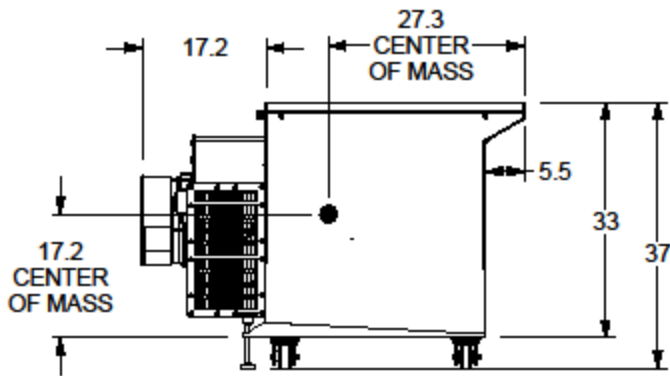
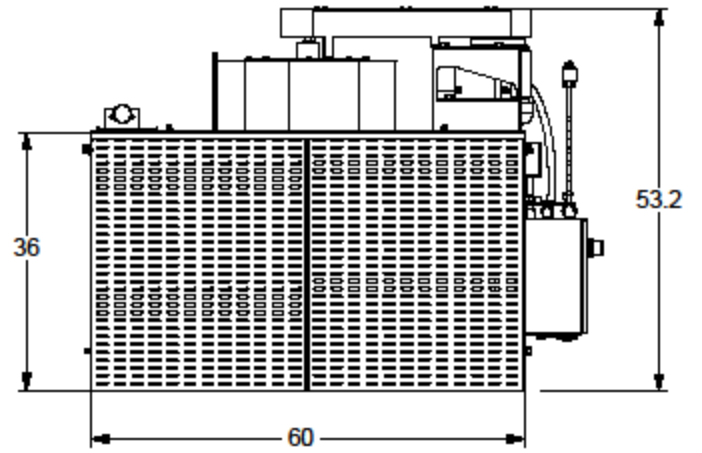
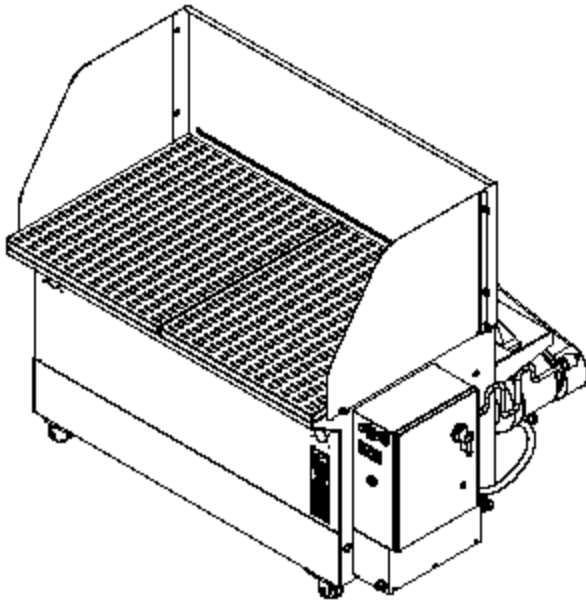



# PARTS

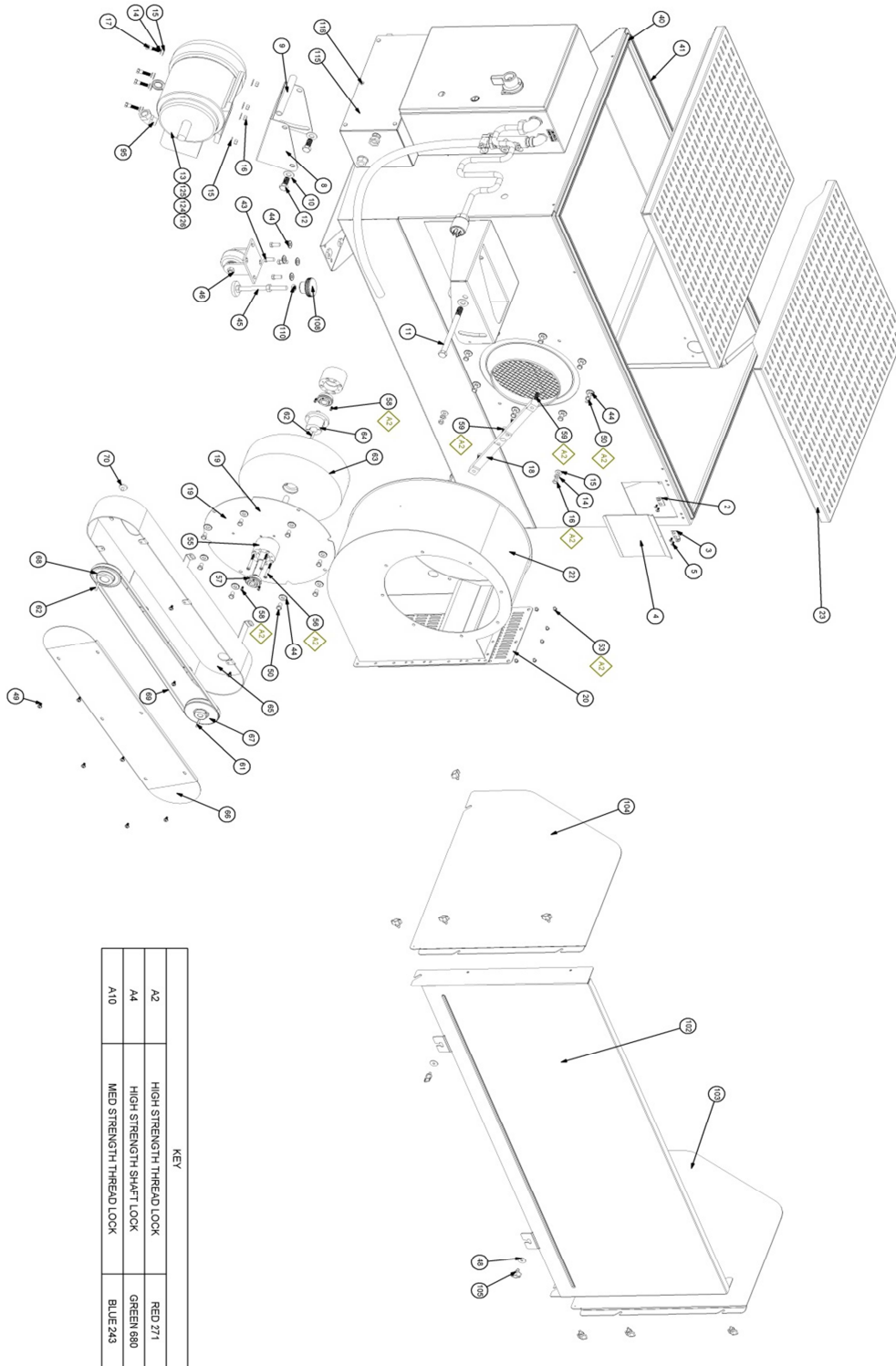

# PARTS

ITEM NO	PART NUMBER	DESCRIPTION	QTY	ITEM NO	PART NUMBER	DESCRIPTION	QTY	ITEM NO	PART NUMBER	DESCRIPTION	QTY
1	64411	MAIN TANK WELDMENT	1	56	98520	S-HCS 1/4-20 Thread, 1-1/4" Length	4	111	98416	IEC 3 WIRE CORD (FT)	6
2	64418	MOUNTING CLIP, LEFT	1	57	98931	ER BEARING	2	112	97657	Nylon Cable Mount	2
3	64419	MOUNTING CLIP, RIGHT	1	58	97073	10-32 X 1/2" BHCS	4	113	98528	1.125 x 1.125 CABLE TIE HOLDER	8
4	64220	H/D RELEASE DOOR	1	59	98518	Socket Head Cap Screw 3/8"-16 Thread, 1-1/4"	4	114	64515	HYBRID CONTROL BOX, 4-20A	1
5	97239	10-32 X 1/2 FSHCS	4	60	64439	1" DIVE SHAFT	1	115	64501	COVER	1
6	97196	QUICK LOCK RECEPTACLE	2	61	97480	CHAMFER KEY	1	116	95206	3/8-16 X 5/8" HEX HEAD BOLT, ZINC	6
7	97308	1/8" ALUMINUM BLIND POP RIVET	2	62	98511	25 X 25 X 1.25 SQ KEY	2	117	98942	Liquid Tight Conduit Fitting, Straight	1
8	64383	MOTOR MOUNT PLATE	1	63	98928	IMPELLER	1	118	97169	1.362" PLUG	1
9	97729	MOTOR MOUNT SPACER	1	64	98930	SPLIT PAER BUSHING	1	119	97238	25 Amp Class CC Limit Fuse, COMB 25	3
10	98514	Fair Washer SAE, 5/8"	3	65	64480	PULLEY GUARD	1	120	98922	QUICK CONNECT, 3/8 OD TUBE X 1/4" NPT	1
11	98517	HHCS 5/8"-11 Thread, 8-1/2 Length	1	66	64478	PULLEY GUARD COVER	1	121	64430	3/8 OD TUBE	1
12	98512	Hex Head Cap Screw 5/8"-11	2	67	98933	DRIVE PULLEY	1	122	98409	12 GA BLACK 3 FT	1
13	98934	X0032 EP MOTOR, 3HP, 3600 RPM	1	68	98932	MOTOR PULLEY	1	123	98410	12 GA RED 7 FT	1
14	95944	3/8 LOCK WASHER	6	69	98935	PULLEY BELT	1	124	98912	RING TERMINAL	1
15	95193	5/16 WASHER	14	70	64920	BUMPER	1	125	98915	CRAMP ON WIRE CONNECT 12	4
16	97217	3/8" HEX NUT	6	71	98788	1/8"-3/12 ALUM. STRAIN RELIEF	1	126	98916	WIRE CONNECTOR	2
17	98521	HHCS 3/8"-16 Thread, 1-1/2" Length	4	72	98534	50 NPT QUICK CONNECT, 90 DEG SWIV.	1	127	98412	12 GA WHITE 7 FT	1
18	64389	Lower Bearing Arm	1	73	98533	50 NPT BREAKTHER VENT	1				
19	64477	IMPELLER MOUNT PLATE	1	74	98525	COIL CONNECTOR	1				
20	64414	EXHAUST GRILL	1	75	98523	3-WAY SOLENOID VALVE	1				
21	64417	ACCESS PANNEL	2	76	97448	SOLENOID VALVE	1				
22	64412	IMPELLER SCROLL	1	77	97333	REDUCER, 1/2 NPT MALE TO 1/4 NPT MALE	1				
23	64422	REMOVABLE WORK SURFACE	2	78	97728	QUICK CONNECT 90°, 3/8 OD TUBE X 1/4" NPT	1				
24	97194	QUICK LOCK RETAINER	2	79	97127	Nylon Head Hex Locknut 5/8"-24	2				
25	97195	QUICK LOCK MALE	2	80	97033	Hex Head Cap Screw 5/8"-24 Thread, 2-1/4"	1				
26	98428	ADHESIVE LABEL, 3 PHASE	1	81	64394	IC LID	1				
27	98422	ADHESIVE LABEL, 230VOLTS	1	82	64385	ISOLATION CHAMBER	1				
28	65056	DESCRIPTIVE PLATE, ELECTRICAL DATA	1	83	97177	10-32 LOCKNUT	2				
29	97102	WARNING LABEL, MAGNESIUM	1	84	97370	#10 WASHER	2				
30	64930	WARNING LABEL, EYE PROTECTION	1	85	97377	10-32 X 3/8" BHCS	2				
31	66904	DESCRIPTION PLATE, COMPANY LOGO	1	86	97429	External Tooth Lock Washer 1"	2				
32	97352	CORD, 124 SECOV	1	87	98522	Through-Wall Chg for 1/2" Tube OD X 1/2" NPT	2				
33	97185	NEMA 1L1-20, MALE PLUG, 250 VAC, 20 Amp	1	88	98936	1/2" SEALING RING	3				
34	97353	90 DEGREE ELBOW	1	89	97163	Conduit Hanger	1				
35	97354	1/2" LOCK NUT	1	90	64375	COLLECTION PAN, FRONT	2				
36	97356	1/2" SEALING RING	1	91	64376	COLLECTION PAN, REAR	2				
37	97220	Liquid Level Sensor	3	92	98938	ENV SEALING FITTING	1				
38	98751	1/2" SEALING RING	1	93	98937	90 DEGREE ELBOW	1				
39	98746	1/2" LOCK NUT	3	94	98939	3/4 X 1.38" NPT NIPPLE	1				
40	97233	WORK SURF GASKET, SHORT	2	95	98943	45 DEGREE ELBOW	1				
41	97232	WORK SURF GASKET, LONG	2	96	97313	BULKHEAD, 1/4 NPT X 1/4 NPT	1				
42	64423	MIST TRAP	2	97	97360	3/4" FEMALE GHT TO 1/4" MALE NPT SWIVEL	1				
43	95228	3/8-16 X 1" HEX HEAD BOLT	16	98	97430	1/8"-3/12 ALUM. STRAIN RELIEF	2				
44	95043	3/8 FLAT WASHER, ZINC	32	99	97744	Fair Gasket	2				
45	97299	BOLT DOWN SWIVEL MOUNT	2	100	97745	Fair Gasket	3				
46	97297	RIGID CASTER	2	101	98944	3/4" CONDUIT	1				
47	97288	SWIVEL CASTER	2	102	64488	BACK SHIELD	1				
48	97314	281 ID X 1" OD X .060 THK FENCES WASHER	2	103	64486	LEFT SIDE SHIELD	1				
49	97192	1/4-20 X 1/2" BRASS INTERNAL LOCK WASHER	11	104	64497	RIGHT SIDE SHIELD	1				
50	95182	3/8-16 X 5/8" HEX HEAD BOLT, ZINC	16	105	64961	ASSY KNOBS, REIM BK-17Z	10				
51	97738	SENSOR BULKHEAD	3	106	98941	DAM PACKING FIBER	1				
52	97423	BULKHEAD GASKET	3	107	98940	SEALING COMPOUND	1				
53	97168	1/4-20 X 3/8" BHCS	16	108	97658	LOCK-DOWN KNOB	1				
54	97389	BULKHEAD NUT	3	109	95186	1/4-20 HEX NUT	2				
55	64489	BEARING SUPPORT HUB	2	110	95138	1/2-13 JAM NUT	2				

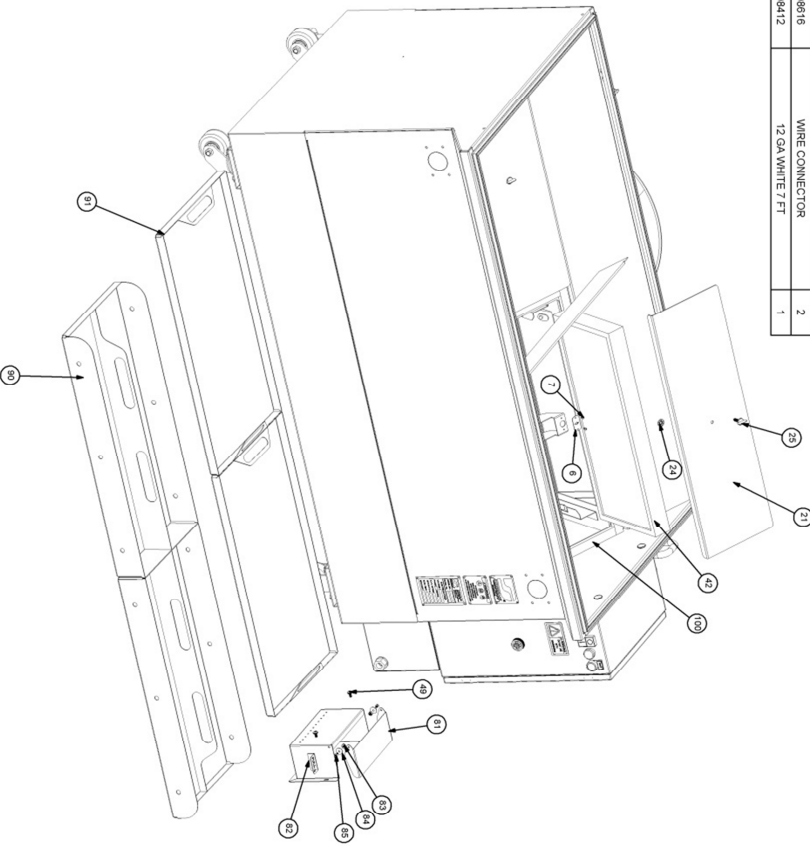

# PARTS

ITEM	P/N	DESCRIPTION	QTY
2	55183	5/16 WASHER	4
4	56426	ADHESIVE LABEL, 3 PHASE	1
5	56422	ADHESIVE LABEL, 230VOLTS	1
6	57352	CORD, 12M SECOW	1
7	57185	RENAL I15-20, MALE PLUG, 250 VAC, 20 Amp	1
8	57353	90 DEGREE ELBOW	1
9	57354	1/2" LOCK NUT	1
10	57356	1/2" SEALING RING	1
11	57200	Liquid Level Sensor	3
12	58751	1/2" SEALING RING	1
13	58746	1/2" LOCK NUT	4
14	57738	SENSOR BULKHEAD	3
15	57423	BULKHEAD GASKET	3
16	57989	BULKHEAD NUT	3
17	58788	.187, 3/12 ALUM. STRAIN RELIEF	1
18	58534	.50 NPT QUICK CONNECT, 90 DEG SWW	2
19	58533	.50 NPT BREATHER VENT	1
20	58525	COIL CONNECTOR	1
21	58523	3-WAY SOLENOID VALVE	1
22	57448	SOLENOID VALVE	1
23	57333	REDUCER, 1/2 NPT MALE TO 1/4 NPT MALE	1
24	57728	QUICK CONNECT 90°, 3/8 OD TUBE X 1/4" NPT	1
25	57127	Nylon-Inset Hex Locknut 5/16"-24	2
26	57033	Hex Head Cap Screw 5/16"-24 Thread, 2-1/4"	2
27	57429	External Tooth Lock Washer 1"	2
28	58522	Through-Wall Cap for 1/2" Tube OD X 1/2" NPT	2
29	58936	1/2" SEALING RING	3
30	57163	Conduit Hanger	1
31	58938	ENV SEALING FITTING	1
32	58937	90 DEGREE ELBOW	1
33	58639	3/4 X 1/8 NPT NIPPLE	1
34	57313	BULKHEAD, 1/4 NPT X 1/4 NPT	1
35	57280	3/4" FEMALE GHT TO 1/4" MALE NPT SWIVEL	1
36	57430	.187, 3/12 ALUM. STRAIN RELIEF	2
37	58944	3/4" CONDUIT	1
38	58841	DAM PACKING FIBER	1
39	58840	SEALING COMPOUND	1
40	55186	1/4-20 HEX NUT	1
41	58416	IEC 3 WIRE CORD (FT)	6
42	57657	Nylon Cable Mount	2
43	58528	1.125 x 1.125 CABLE TIE HOLDER	8
44	54515	HYBRID CONTROL BOX, 4.20A	1
45	58942	Liquid Tight Conduit Fitting, Straight	1
46	57168	1.362" PLUG	1
47	57238	25 Amp Class CC Limbless, COMB 25	3
48	58022	QUICK CONNECT, 3/8 OD TUBE X 1/4" NPT	1
49	54430	3/8 OD TUBE	1
50	58409	12 GA BLACK 3 FT	1
51	58410	12 GA RED 7 FT	1
52	58412	12 GA WHITE 7 FT	1

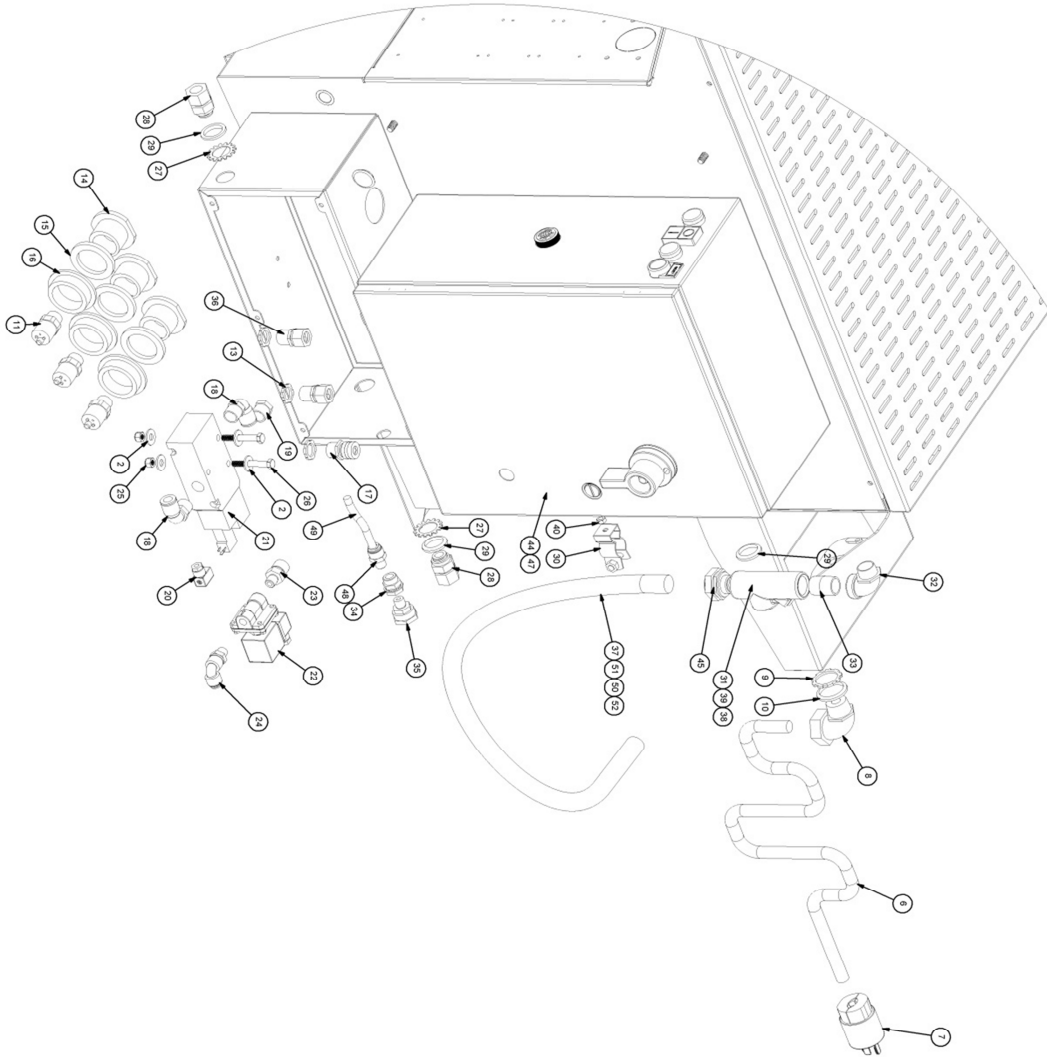

# SCHEMATIC

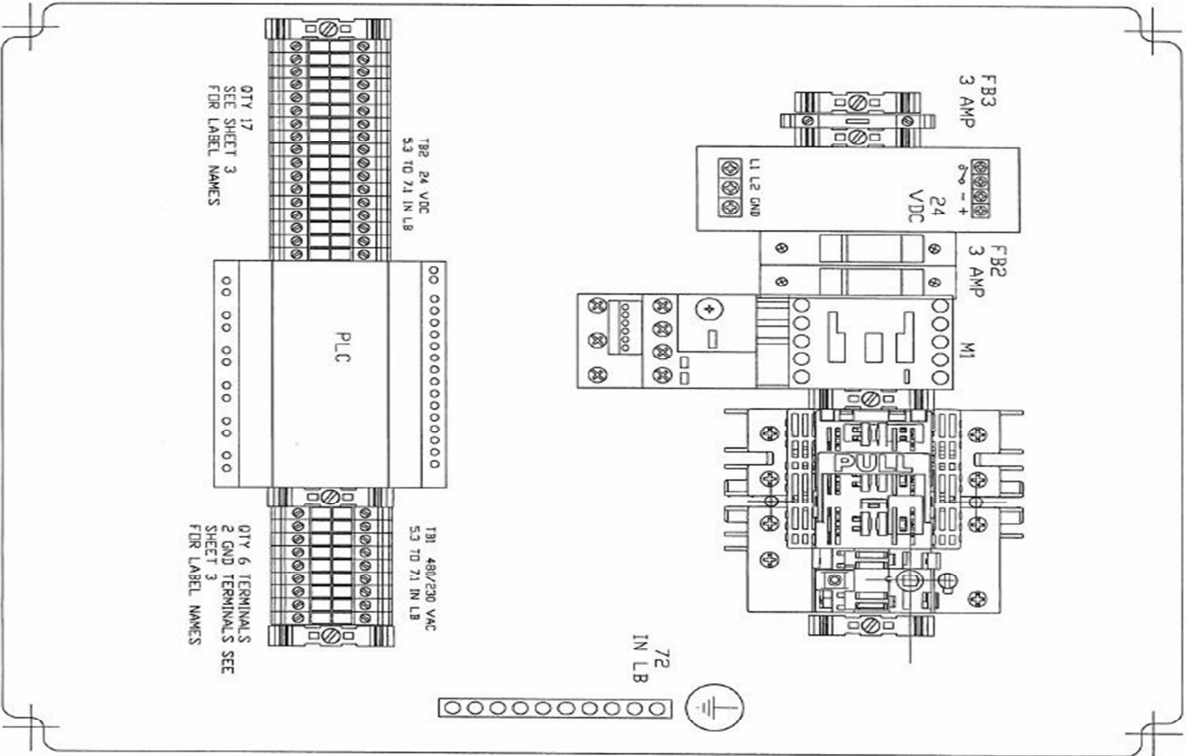

THIS DOCUMENT IS THE PROPERTY OF K.J. ELECTRIC. THE INFORMATION CONTAINED HEREIN IS CONFIDENTIAL AND IS NOT TO BE REPRODUCED OR TRANSMITTED IN ANY FORM OR BY ANY MEANS, ELECTRONIC OR MECHANICAL, INCLUDING PHOTOCOPYING, RECORDING, OR BY ANY INFORMATION STORAGE AND RETRIEVAL SYSTEM, WITHOUT THE WRITTEN CONSENT OF K.J. ELECTRIC.

Location: **WO# 841222**  
 Project: **SP0-73465-0**  
 PO#:

CUSTOMER: **DYNABRADE**  
 PROJECT: **NEMA 4, CONTROL PANEL FOR DUST COLLECTOR**

**K.J. ELECTRIC**  
 5894 EAST MOLLOY RD. SYRACUSE, N.Y. 13211  
 (315) 454-5525 FAX (315) 454-5564

NO.	REVISION	DATE
2	AS BUILT ADDED SHEET & ROW	4/25/13
1	LAYOUT FOR ENCLOSURE DWG 97404	04/08/13
0	ORIGINAL	03/08/13

DWN	CHK	REV	DWG. NO.	SH
1	2	2	P1958-1	1

# SCHEMATIC

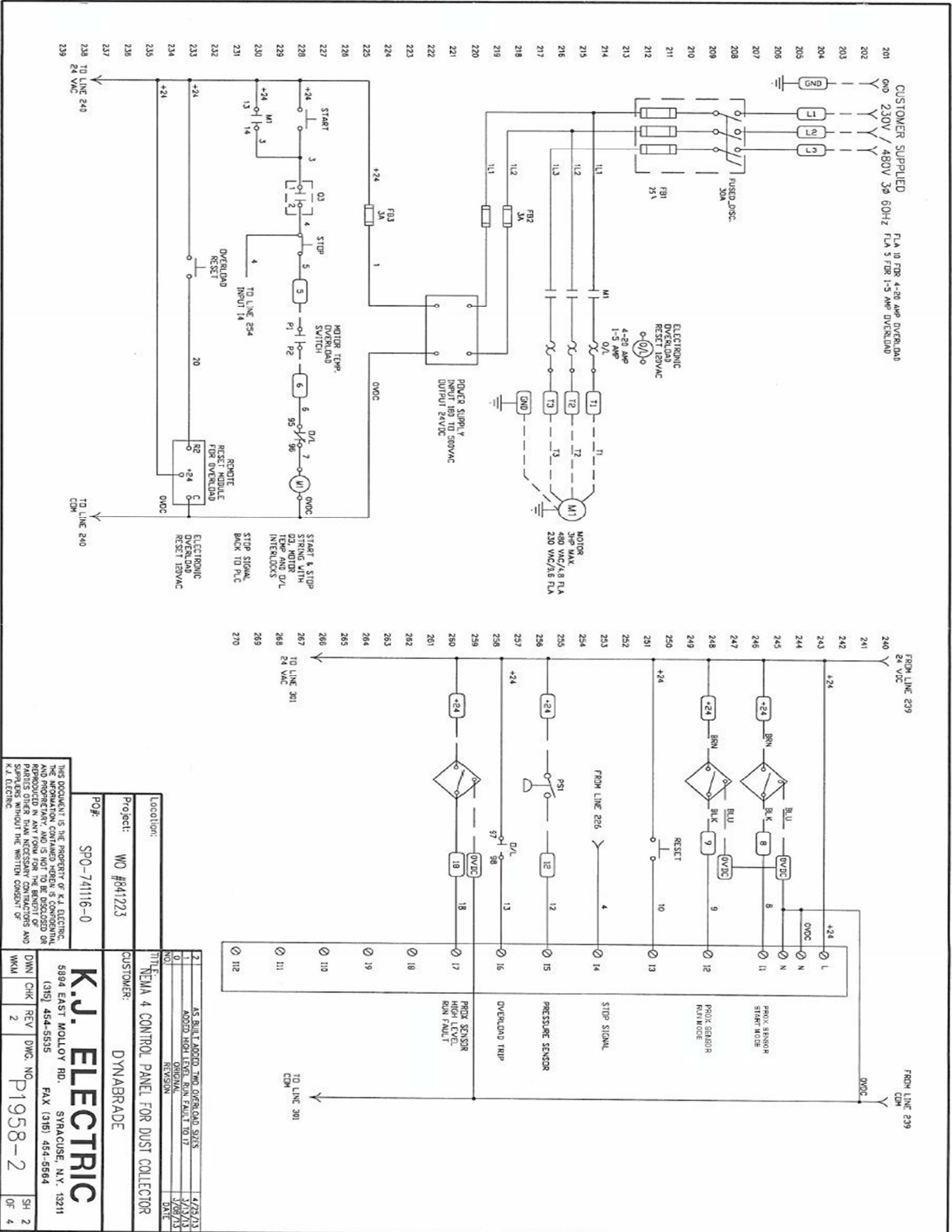

THIS DOCUMENT IS THE PROPERTY OF K.J. ELECTRIC. THE INFORMATION CONTAINED HEREIN IS CONFIDENTIAL AND PROPRIETARY AND IS NOT TO BE DISCLOSED OR REPRODUCED IN ANY FORM FOR THE BENEFIT OF OTHERS WITHOUT THE WRITTEN CONSENT OF K.J. ELECTRIC.

Project: WO #841223  
 PO#: SP0-741116-0

5894 EAST MOLLOY RD. SYRACUSE, N.Y. 13211  
 (315) 454-5535 FAX (315) 454-5564

DWN CHK REV DMC NO SH 2  
 WKM 2 P1958-2 OF 4

Location:	WO #841223
Project:	SP0-741116-0
Customer:	DYNABRADE
Title:	NEMA 4 CONTROL PANEL FOR DUST COLLECTOR
AS BUILT APPROVED AND OVERLOAD SIZE	4/23/21
ADDED SIGNAL LINE FROM TRIP TO TRIP	3/28/21
ORIGINAL	3/28/21
REVISION	DATE

# SCHEMATIC

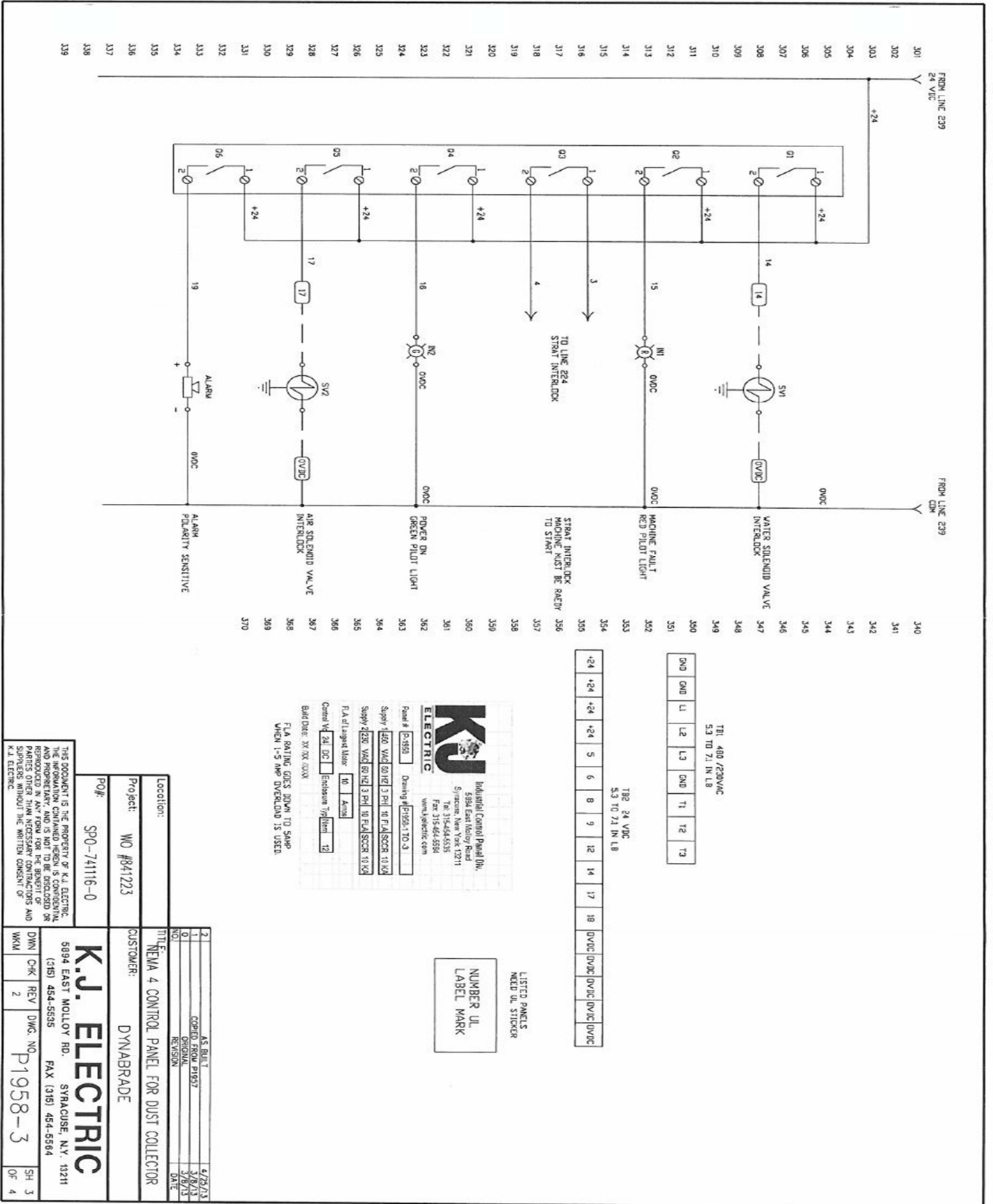

**KJ ELECTRIC**  
Industrial Control Panel Div.  
5884 East Mollloy Road  
Syracuse, New York 13211  
Tel: 315-454-5535  
Fax: 315-454-5594  
www.kjelectric.com

Panel # P-1950 Drawing # P-1950-1 TO -3  
Supply 480 VAC 60 HZ 3 PH 0 FCAL SCORE 10.04  
Supply 230 VAC 60 HZ 3 PH 10 FCAL SCORE 10.04  
F.A. of Largest User: M. Amos  
Control Vd: 24 VDC Enclosure Type: Panel 12  
BARDORF 'X' BOX COOK  
FLA RATING: GCS 200A TO 500A  
WHEN 1-3 AMP OVERLOAD IS USED

LISTED PANELS  
NEED UL STICKER  
NUMBER UL  
LABEL MARK

Location:	Project:	PO#:
	WO #R41223	SP0-74116-0
TITLE: NEMA 4 CONTROL PANEL FOR DUST COLLECTOR		
CUSTOMER: DYNABRADE		
<p><b>K.J. ELECTRIC</b> 5884 EAST MOLLOY RD. SYRACUSE, N.Y. 13211 (315) 454-5535 FAX (315) 454-5594</p>		
AS BUILT	5/29/13	
COPIED FROM P1957	3/8/13	
ORIGINAL	3/8/13	
REVISION		
DWG		
5894 EAST MOLLOY RD. SYRACUSE, N.Y. 13211	REV	DWG NO.
(315) 454-5535 FAX (315) 454-5594	2	P1958-3
DKM	CHK	REV
WKW		2
	DWG NO.	P1958-3
	SH	3
	OF	4

# SCHEMATIC

BILL OF MATERIAL

Line#	Qty	Part #	Desc:	Key	Mfg.
1	1	FBC030CDT	Disconnect fused 30 AMP class CC		Ferraz
2	1	SG200-5	shaft		Ferraz
3	1	HGPR14L	Red handle		Ferraz
4	1	GCX3203-24	Reset button yellow		Automation direct
5	1	ECX2051-24L	Red pilot light		Automation direct
6	1	GCX3150	on/off switch		Automation direct
7	1	EASY719-DC-RCX	EZ relay 719, VDC, relay, no screen		CH
8	1	ECX2052-24L	Green Pilot light		Automation direct
9	1	GBK10	Ground block 10 position		CH
10	1	XTCE015B10TD	Contactor 12 AMP, 24VDC coil, 1NO AUX		CH
11	1	XTOE020BCS	Electronic overload 4-20 amps		CH
11A	1	XTOE005BCS	Electronic overload 1-5 amps		CH
12	1	C440-XCOM	Remote reset module with 24 VDC coil		CH
13	1	M22-D-B-GB14-K10	Button for remote reset		CH
14	0.3	XBANS3575P	Din rail		CH
15	3	XBAESS35C	End Stop, 1screw, 35mm din rail,		CH
16	20	XBUT4	Terminal block, 10AWG, 6.2mm, 30Amp, Gray,		CH
17	2	XBACUT10	End Cover, 12-6AWG, 5.2-10.2mm,		CH
18	5	XBMB2B6	Label, 6.2mm, White, strip of 10,		CH
19	1	XBUT6FBNL24	Terminal block fuse holder 24VDC with indicator		CH
20	2	XBUT4PE	GND Terminal block green		CH
21	1	WDR-120-24	Power supply 120 watt 180 to 500 vac input, 24vdc output		TRC/Meanel
22	1	97367	Fuse holder class CC, with indicator/pole		Automation direct
23	2	ATOR3	Fuse 3 AMP class CC time delay		Ferraz
24	3	ATDR12	Fuse 12AMP class CC		Ferraz
25	1	GDL3	Fuse 3AMP glass		Ferraz
26	1	CSD20168	Enclosure 20H x 16W x 8 D, NEMA-12		Hoffman
27	1	CP2016	Sub panel 18.2 x 14.2		Hoffman

OVERLOAD CAN BE ITEM 11 OR 11A  
CHECK OVERLOAD CURRENT RATING FOR SIZE.

Location: **WO #841223**  
 Project: **SP0-741116-0**  
 PO#

2	AS BUILT	04/28/73
1	SEE SHEET 1	3/8/73
1	REVISION	3/8/73
NO.	REVISION	DATE

TITLE: **NEMA 4 CONTROL PANEL FOR DUST COLLECTOR**  
 CUSTOMER: **DYNABRADE**

**K.J. ELECTRIC**  
 5894 EAST MOLLOY RD. SYRACUSE, N.Y. 13211  
 (315) 454-5535 FAX (315) 454-5864

DWN	CHK	REV	DWG. NO.	SH
WKM		2	P1958-4	4

THIS DOCUMENT IS THE PROPERTY OF K.J. ELECTRIC. THE INFORMATION CONTAINED HEREIN IS CONFIDENTIAL AND PROPRIETARY, AND IS NOT TO BE DISCLOSED OR REPRODUCED IN ANY MANNER WITHOUT THE WRITTEN CONSENT OF K.J. ELECTRIC.

# **WARRANTY**

## **Downdraft Tables, Metal Capture Downdraft Tables and Metal Capture Downdraft Stations 12 Month Warranty**

Dynabrade warrants all Downdraft Tables, Metal Capture Downdraft Tables and Metal Capture Downdraft Stations against defects in workmanship and materials under normal use and service for a period of 12 months from the date of purchase as set forth herein.

Customer must return the defective tool to Dynabrade within 12 months from the date of purchase. Upon examination and review at Dynabrade's factory, Dynabrade shall confirm whether the tool qualifies for warranty status, in which case Dynabrade shall repair or replace the tool at no charge to the customer. Exceptions for in-field examination shall be made only at Dynabrade's discretion.

This warranty is contingent upon proper use of the Downdraft Tables, Metal Capture Downdraft Tables and Metal Capture Downdraft Stations in accordance with factory recommendations, instructions and safety practices. It shall not apply to equipment that has been subjected to misuse, negligence, accident or tampering in any way so as to affect its normal performance. This warranty does NOT cover normally wearable parts and accessories, including, but not limited to, filters, work surfaces, electrical cords and plugs, fuses, gaskets, v-belts, bearings and casters. This warranty does NOT cover chipped paint or corrosion.

To be considered for warranty, tools must be sent back to our factory, transportation prepaid by user. Please send tool back to attention "Repair Department" with note fully explaining the nature of the problem along with a copy of original invoice indicating model and serial number. Exceptions for in-field repair shall be made only at Dynabrade's discretion.

**THIS WARRANTY IS MADE IN LIEU OF ALL OTHER WARRANTIES, EXPRESS OR IMPLIED, INCLUDING, BUT NOT LIMITED TO, WARRANTIES OF MERCHANTABILITY OR FITNESS FOR A PARTICULAR PURPOSE, AND THERE ARE NO OTHER WARRANTIES THAT EXTEND BEYOND THIS EXPRESS WARRANTY.**

Dynabrade will not be liable for damages to products, other property or persons due to improper use or through attempts to use products for other than their intended use. **DYNABRADE WILL NOT BE LIABLE TO CUSTOMER OR ANY THIRD PARTY FOR ANY SPECIAL, CONTINGENT, INCIDENTAL, INDIRECT OR CONSEQUENTIAL DAMAGES.**

Dynabrade's liability with respect to a claim for any other damages arising out of or connected with the manufacture, sale, purchase, non-delivery, use or performance of any product sold by Dynabrade will in no event exceed to the price paid for the product.